



edition 2015

Composite Materials

an introduction

A VKCN publication

R.P.L. Nijssen

Composite Materials

An Introduction

R.P.L.Nijssen

1st English edition, based on 3rd Dutch edition (ISBN: 978-90-77812-51-8)

Copyright©2015 R.P.L. Nijssen, Inholland University of Applied Sciences

ISBN: 978-90-77812-471



Composites – basic knowledge, author: R.P.L. Nijssen, is licensed under a Creative Commons Attribution – Share Alike 4.0 International license. Go to <http://creativecommons.org/licenses/by-sa/4.0> to read a copy of this license.

This book may be obtained in digital form (Open Access) via:

www.inholland.nl/lectoraatgrootcomposiet

and www.vkcn.nl

This translation was made possible by the Inholland and the Arnhem and Nijmegen University of Applied Sciences, with special thanks to Rens Horn.

Printed copies have been made available by Inholland University of Applied Sciences

These copies can be obtained via VKCN (shipment and administration fees apply)



Preface

In today's industry, fiber reinforced thermosets and thermoplastics play an important role in production, engineering, usage and education. To promote the well-thought use of these composite materials, the book in front of you intends to provide an introductory course to composites for students at the Dutch Universities of Applied Sciences (Hogescholen) and is a translation based on the Dutch book 'Composieten – basiskennis' (3rd edition), developed and supported by the Dutch Association for Composites in the Netherlands (VKCN).

The Dutch Universities of Applied Sciences ('Hogescholen') are part of the academic system and provide education and research that is generally less theoretical and more applied than universities. Students graduate with the title of 'Bachelor of Engineering', and some continue to a university Master's programme, often after 6 months to a year of additional pre-master education.

This book is not intended specifically for the 'usual suspects' in terms of composite courses, viz. those given at aeronautical or aerospace departments. It is more general and aims to provide basic knowledge to any technical Bachelor-level student, in aeronautical and mechanical engineering, civil engineering and architecture, technical business studies, etc. It mostly excludes detailed mechanics of composites (which is often a large part of composite textbooks), and focuses on the most important topics related to manufacturing, materials, processes, design, testing, sustainability, and certification.

In this category, the body of Dutch literature was quite limited and partly outdated at the time when a group of teachers from various 'Hogescholen' convened and decided to try and solve this issue. Even in this day and age, for many Dutch students at the 'Hogescholen', reading and studying in Dutch is still easier than reading English. Furthermore, there is a great wealth of English textbooks on composite materials, there is really no urgent need to add to that. Therefore it was decided to write the book in Dutch.

The reason that we, more or less against the above logic, made this English version is a highly pragmatic one: in many 'Hogeschool' departments, the curriculum contains parallel English and Dutch spoken tracks, and ideally these use the same textbooks.

Nevertheless, even if the world does not really need yet another book on composites, we hope that it can still play a role in fostering well-thought use of composite materials in engineering. In the Netherlands, we were/are in the situation that exciting new developments are driven by innovative industry, often small- and medium enterprises. These companies hire alumni of, among others, our 'Hogescholen', which often need to be trained 'on the job' for the company's specific processes. On the other hand, there

are several sectors where composites are regarded as new materials. The potential for improving or complementing design with these materials is very promising, but knowledge of materials and how to design with them is lacking because it is often limited in the curricula of 'Hogescholen' and Universities.

Education on the potential as well as pitfalls of composites is crucial for initiating and driving new developments in many engineering disciplines.

In the collaborative spirit of the contributors, this textbook is published 'Open Access'.

Contents

Preface	v
Chapter 1 Materials	13
1 - 1 What is a composite?	13
1 - 2 Pros and cons of composites	14
1 - 3 Fibres	17
1 - 3.1 The role of fibres in a composite	17
1 - 3.2 Glass and carbon – the most commonly used fibres	17
1 - 3.3 Other fibres	20
1 - 3.4 Fibre properties	20
1 - 3.5 Plies and laminates	20
1 - 3.6 Yarns, bundles, textiles	21
1 - 4 Polymers	24
1 - 4.1 The role of polymers as a matrix in a composite	24
1 - 4.2 Thermoplastics	26
1 - 4.3 Thermosets	26
1 - 4.4 Different kinds of polymers	26
1 - 4.5 Material properties	30
1 - 5 Glass transition temperature	31
1 - 6 Viscosity and permeability	31
1 - 7 Sizing	33
1 - 8 Sandwich and core materials	33
1 - 9 Sources	36
1 - 10 Exercises for this chapter	37
Chapter 2 Production methods	39
2 - 1 Moulds and plugs	39
2 - 2 Categories of production methods	41
2 - 2.1 Raw materials	41
2 - 2.2 Aiding materials and devices	42
2 - 3 Processing methods	43
2 - 3.1 Open-mould processes for thermosets	43
2 - 3.2 Closed-mould processes	49

2 - 4	Further machining and material removal	52
2 - 5	Sources	53
2 - 6	Exercises for this chapter	54
Chapter 3 Design of laminates		57
3 - 1	Description of a laminate	57
3 - 2	Failure mechanisms	58
3 - 2.1	Mechanical failure mechanisms	59
3 - 2.2	Other failure mechanisms	62
3 - 3	Calculations with composites	65
3 - 3.1	Estimating stiffness and strength	65
3 - 3.2	Classical laminate theory	69
3 - 3.3	Finite Element Method	76
3 - 3.4	Rules of thumb for laminate design	77
3 - 4	Sources	81
3 - 5	Exercises for this chapter	82
Chapter 4 Sandwich		85
4 - 1	Bending of sandwiches	86
4 - 2	Buckling of sandwiches	88
4 - 3	Sources	90
4 - 4	Exercises for this chapter	91
Chapter 5 Joints		95
5 - 1	Adhesive joints	95
5 - 1.1	Making good adhesive joints	95
5 - 1.2	Failure of adhesive joints	98
5 - 1.3	Types of adhesive	98
5 - 2	Mechanical joints	99
5 - 2.1	Surface pressure and stress around a hole	99
5 - 2.2	Failure of mechanical joints	99
5 - 2.3	Use of inserts	100
5 - 2.4	Screwed connections	100
5 - 2.5	Bolted connections	100
5 - 2.6	Hybrid and other joints	101
5 - 2.7	Joints in thermoplastics	102
5 - 3	Sources	104
5 - 4	Exercises for this chapter	105

Chapter 6 Sustainability	107
6 - 1 Life Cycle Analysis	107
6 - 2 Sustainability of composites	108
6 - 2.1 Production of composites	108
6 - 2.2 Maintenance and repair	109
6 - 2.3 Energy saving in the construction industry	110
6 - 2.4 Composites in motion	110
6 - 2.5 End of life	112
6 - 3 Sources	113
Chapter 7 Testing	115
7 - 1 Why test?	115
7 - 2 Test- and measurement methods for composites	116
7 - 2.1 Test set-up and methods of measurement	116
7 - 2.2 Types of mechanical tests	119
7 - 2.3 Other tests	123
7 - 3 Interpretation of test results	126
7 - 4 Sources	129
7 - 5 Exercises for this chapter	130
Chapter 8 Standards and Certification	133
8 - 1 A case of trust	133
8 - 2 Test standards	134
8 - 3 Design standards	134
8 - 4 Standards development	135
8 - 5 Design manuals	137
8 - 6 Sources	138
Answers to exercises	139
Content and illustrations	147
VKCN working group Education	149

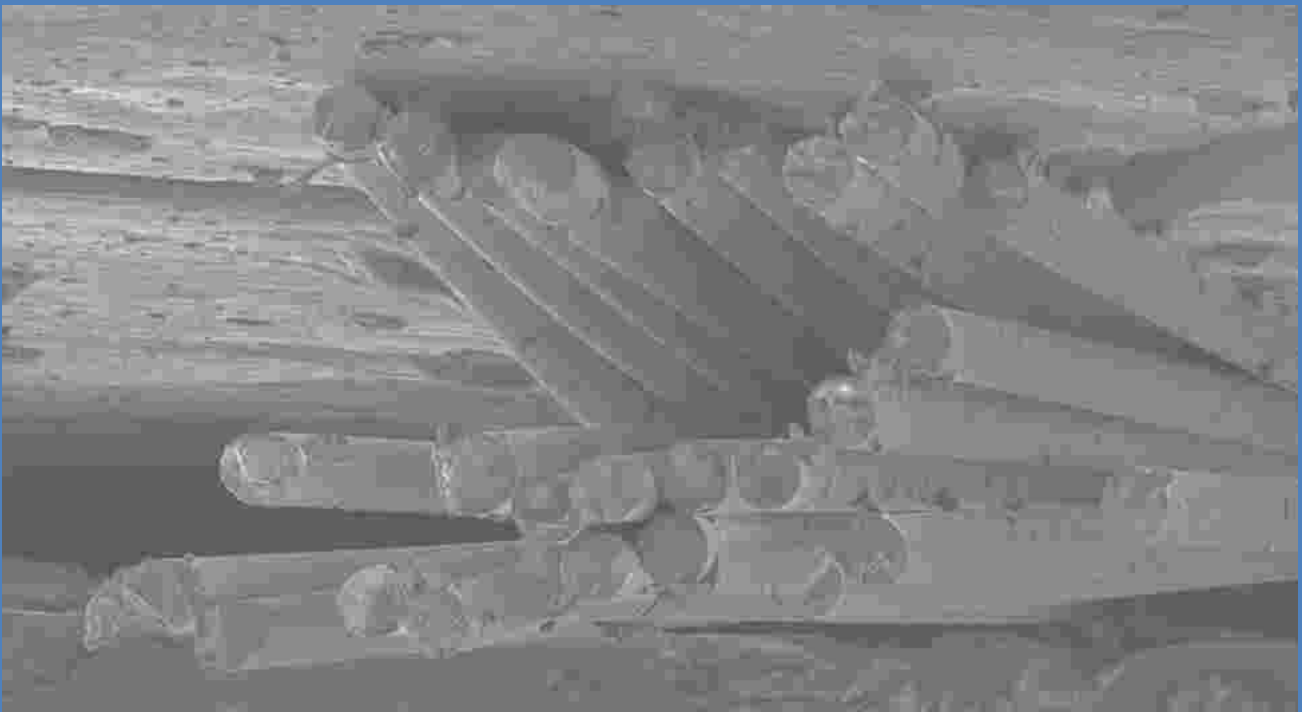

Microscopic image of a glass fibre/epoxy composite material. The loose fibres, and, in the background, the matrix which holds the fibres together are clearly visible. The diameter of these fibres is approximately 17 micrometer.

Chapter 1

Materials

After reading this chapter, you will know the definition of a composite, be familiar with the role of fibres and matrix, and be able to describe the production of a number of fibre types as well as the curing of various resin types. You will know the most important properties of commonly used fibres, resins and textiles.

1 - 1 What is a composite?

This chapter provides an overview of the materials from which a composite can be composed, and their most important properties. First we shall determine what a composite actually is. Various definitions of composites may be used:

- 'a combination of a stronger and a weaker material'
- 'a material composed of different parts'
- 'a combination of two materials'

The above definitions pose some problems. The first two leave us without an answer to the question: "Why make such a combination?". The third definition implies that alloys, two-component adhesives and solutions are composites. The first and last definitions are restrictive, since no further materials are included. In this book, the following definition will be used:

A composite is a material structure that consists of at least two macroscopically identifiable materials that work together to achieve a better result.

This is quite a mouthful, but at least the objections raised above no longer apply. This description still requires further explanation.

When a composite product is manufactured, the material itself and the structure are often made at the same time. Usually there is no raw, unmachined material that is kneaded, deformed and assembled into a structure, but the structure as well as the material are made in one go; hence the term 'material structure'. Composites as defined in this book are manufactured of fibres mixed with a (polymer) resin or matrix. These two components do not dissolve into each other and remain visible ("macroscopically identifiable"). The favourable properties of fibres and matrix are utilised to the maximum, while the unfavourable properties

of one component are compensated for by the other component as much as possible, achieving a structure that could not have been made with either of the separate components.

In this regard, for composites, one often refers to (a variation of) the 'materials triangle' (see Figure 1). This triangle shows that the possibilities of arriving at a particular structure depend to a large extent on the material and the production method.

The restriction 'macroscopically identifiable materials' excludes alloys, mixed adhesives and salt solutions. In particular, this book discusses composites that consist of fibres that have been embedded in a polymer material – i.e. fibre-reinforced plastic (FRP). In such composites, the strength of the fibres is used to make a material that is stronger than the polymer alone (see also 1 - 3.1 and 1 - 4.1).

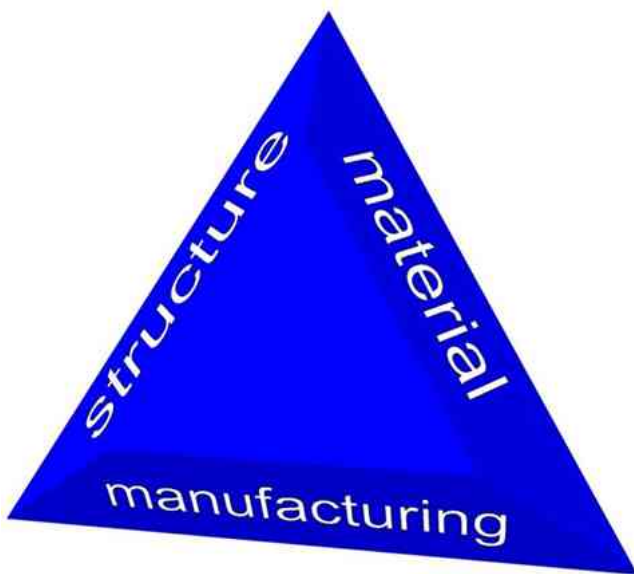

Figure 1: The Materials Triangle

for building ships was once regarded as revolutionary and later the same applied to steel. This process was not straightforward. A certain motivation was required for adopting new materials (e.g. strength, stiffness, shortage of existing materials) and new construction methods became necessary. Shipyards, for example, disappeared or had to be completely reorganised in order to process the new material. Design methods and computational procedures changed, often through a process of bitter experience; for example, unexpected brittle fractures in American Liberty ships eventually helped improve steel ship design.

It can be disputed that composites are revolutionary materials. As Figure 2 illustrates, modern composites have been used in structures for more than 60 years. However, a 'transition to composite' seems to be gradually taking place in more and more industries (see e.g. Figure 3).

Engineers are considered to be familiar with available materials and – based on project requirements – to be capable of selecting the right materials for the job. Know-how can be

This book focuses on FRP for use in load-bearing structures. Here, a 'better result' refers to applications of composites that make the structure stronger, more rigid, better capable of withstanding sustained loads etc. than when the materials are used on their own. It does not mean that the structure necessarily is better than a structure with other materials.

1 - 2 Pros and cons of composites

Composite materials are relatively unknown and are often regarded as high-tech materials for modern applications. Almost every material has previously gone through this phase; even wood used



Figure 2: The 1961 Chevrolet Corvette, with fibre glass body parts [1]

obtained through modern software, such as CES Edupack [3], which is able to compare the properties of countless materials.

In addition, it is necessary to know both the advantages and disadvantages of a material. The table below summarises a number of these possible (!) pros and cons. Also see [2].



Figure 3: Transition from metal to composite in the transport sector [4]

Table 1: Pros and cons of composite materials

Advantages	Disadvantages
<p>Weight saving</p> <p>High degree of freedom in form, material and process</p> <p>Easy to colour</p> <p>Translucent</p> <p>High degree of integration of functions possible</p> <p>Strength, stiffness, thermal and electrical resistance can be designed</p> <p>Low total maintenance costs</p> <p>Water- and chemically resistant</p> <p>Use of durable materials possible</p> <p>Automated manufacturing possible</p>	<p>High material costs</p> <p>Sophisticated computational methods sometimes required</p> <p>Colour and gloss preservation not always predictable</p> <p>Relatively limited knowledge on structural behaviour of details and connection methods</p> <p>Finishing not yet well developed</p> <p>Stiffness and failure behaviour can be undesirable; sensitive to temperature, fire and lightning strike</p> <p>High costs of raw materials</p> <p>Sensitive to UV light</p> <p>Recycling not yet well developed</p> <p>Sometimes capital intensive production methods (e.g. automated methods)</p>

The above-mentioned advantages and disadvantages relate to a 'current' material that is not further specified. Careful distinctions should be made per design, because characteristics are not applicable or incompatible in some cases. An example is the lower weight; for objects that do not need to be moved often and are not appreciably loaded by their own weight, it would not make sense to opt for lightweight design. Furthermore, costs and sustainability of a design should always be considered throughout the life cycle. The costs of components or life-cycle phases can soar (e.g. investments in a mould) or materials may not be sustainable. For example, the production of carbon fibres requires high amounts of energy. This may sometimes be compensated for by the total costs of use due to lower maintenance costs or energy consumption during transport or in energy generation processes such as wind turbines.

The relative number of advantages and disadvantages means little in respect to the general applicability of a composite. A particular aspect of a design may either lead to guaranteed success or be show-stopper.

1 - 3 Fibres

1 - 3.1 The role of fibres in a composite

The fibres generally determine the strength and stiffness of the composite material (see frame describing strength, stiffness and transverse contraction). A polymer to which directional fibres have been added is much stronger in the fibre direction than the polymer without fibres. Perpendicular to the fibre direction, the increase in stiffness is less pronounced. The strength in that direction is smaller, since the fibres act as stress concentrators. In practice, fibres are often incorporated in different directions.

1 - 3.2 Glass and carbon – the most commonly used fibres

Although many types of fibres exist that are suitable as reinforcement in a composite material, glass fibres and carbon fibres (carbon/graphite) are most commonly used. Production methods of these fibres differ.

To produce glass fibres, silicon oxide (SiO_2 , from sand) is heated together with various additives above its melting point. The molten material is then fed to small channels with small holes in the bottom (of approx. 2 mm diameter) through which the molten material passes. The viscous melt is wound on a coil. This is done at high speed (tens of metres per second). As a result, the molten fibres are stretched and become much thinner – approximately 20 micrometers in diameter. Immediately after leaving the extrusion sleeves (which are made of a platinum-rhodium alloy that is capable of withstanding high temperatures), the fibres are sprinkled with water so that they solidify at high speed. The water contains an additive to facilitate further processing of the fibres. See Figure 4. For a further discussion of the fibre to textile process, see 1 - 3.6.

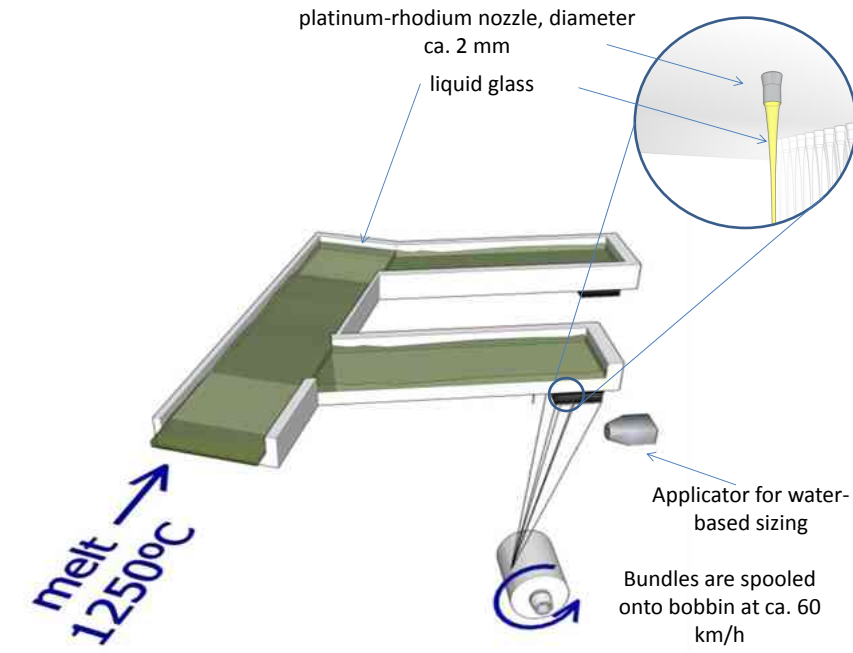

Figure 4: Overview of glass fibre production

There are various types of glass, each with different material properties. Each type is designated by a letter. The most common type is E-glass. Other types include S-glass (increased strength and stiffness), C-glass (chemically resistant), D-glass (low dielectric constant and thus highly suitable for application in radomes, for example). The type of glass is determined by its chemical composition.

The process described above is relatively cheap but involves a number of complicating factors. The constituents must be mixed in the correct ratios. Also, changing the chemical composition requires time and material, since the furnace must first be purged. The material of the glass furnace has a limited lifetime of a few years.

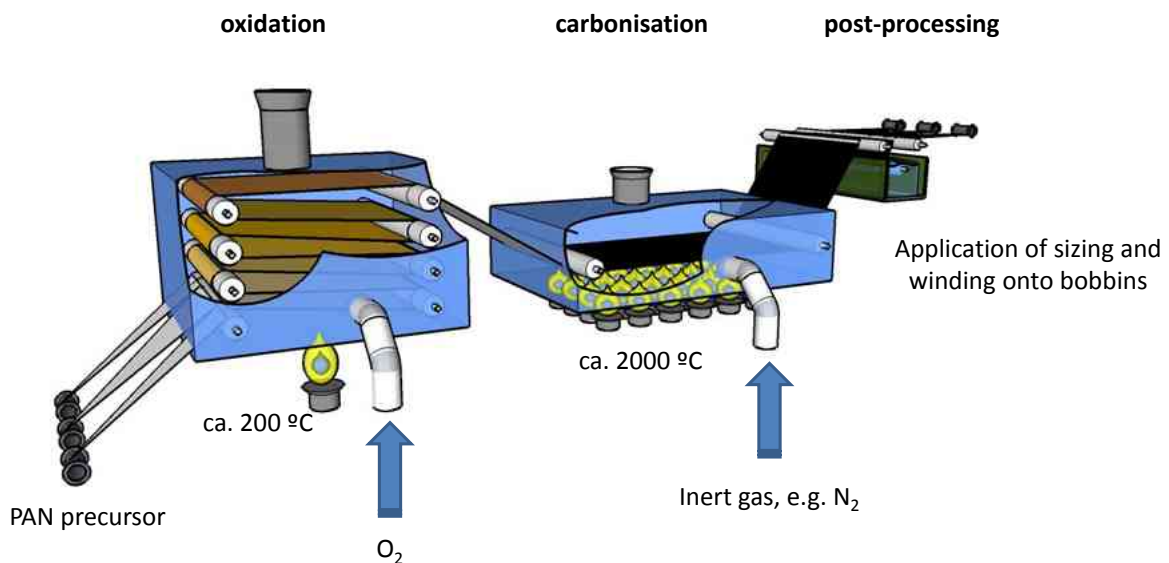
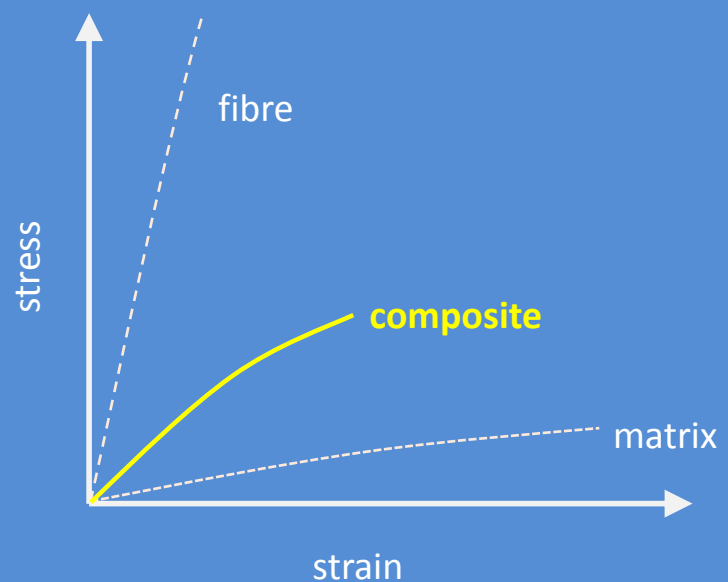

Figure 5: Overview of carbon fibre production

Carbon fibres are produced in a completely different way (Figure 5). Various raw materials can be used, provided their chemical compound has a high carbon atom content. In general, PAN (polyacrylonitrile), pitch or rayon/viscose (now used in e.g. bio-composites) are used. PAN is a manufactured product that has well-defined properties. Pitch, on the other hand, is a natural product. PAN is preferred for consistent quality, while pitch is cheaper. Threads drawn from PAN or pitch pass through three stages: oxidation at approximately 200°C (the fibres obtain their characteristic black colour in this stage); carbonisation at 800-1600°C (various components, such as nitrogen atoms, are removed in an inert atmosphere); and ultimately graphitisation (where the fibre obtains its definitive composition). The fibres are stretched during this process, so that the orientation of the carbon chains in the material runs parallel to the fibre direction as much as possible, and an anisotropic fibre is formed. Carbon fibres are often transversally isotropic and have a much higher stiffness in the axial direction than in the transverse direction (see page 25).

Stiffness, strength, and Poisson contraction

The response of a material to an external load is often illustrated in a stress-strain diagram. One axis displays the stress (load F divided by stressed area A). The other axis displays strain: relative elongation, i.e. elongation divided by original length. The slope in this diagram is a measure of flexibility, this is called the modulus of elasticity or Young's modulus. Failure occurs at failure strain and -stress. The larger the failure stress, the stronger the material. The larger the resistance against elongation, the stiffer the material is. (NB: although these concepts may be confused in colloquial language: the opposite of strong is 'weak'; the opposite of stiff is 'flexible'.) In composites, the strength and stiffness depend on fibre orientation as well as fibre and matrix properties.



Elongation of a material in one direction typically results in some contraction in the perpendicular direction. This is called transverse contraction or Poisson contraction (reflected in Poisson's ratio).

1 - 3.3 Other fibres

In addition to glass and carbon, many other fibre reinforcements are used. With respect to the manufacturing method, basalt fibres closely resemble glass fibres. Basalt (volcanic rock)

is heated in a furnace, similar to glass, after which threads are drawn. The basalt is ready for processing 'as is' – which means components do not need to be mixed beforehand. The composition of basalt depends on the site where it is mined, however. This means that ultimately there is only a limited supply. Furthermore, basalt is more difficult to melt than glass and more abrasive. Therefore, extrusion sleeves must be replaced more frequently. This leads to basalt being more expensive than E-glass, although it is still cheaper than the more expensive kinds of glass and carbon.

Other commonly applied fibres are aramid fibres (aromatic polyamides), known by the brand names Kevlar and Twaron. The polymer chains in these fibres are strongly directed during the manufacturing process, resulting in the formation of a stiff fibre. The specific gravity of these fibres is very low, resulting in good specific properties. An important advantage of these fibres is their great tenacity, making them very suitable for application in bullet-proof vests.

During processing and in use, natural fibres (from plants such as flax, hemp, bamboo and wood) have the disadvantage of being sensitive to moisture absorption and rotting. Another disadvantage of plant fibres is that they are fairly short. Their strength and stiffness, certainly in relation to their weight, can be of the same order as that of synthetic fibres (see Table 2).

1 - 3.4 Fibre properties

Some important material properties of reinforcing fibres are shown in Table 2. Compare these values for a moment with those for a 'known' material such as steel. Chapter 7 discusses the way in which all these properties are determined.

1 - 3.5 Plies and laminates

Key terms in working with composites are ply and laminate. A layer of impregnated fibre reinforcement is called a lamina or ply; a stack of plies is called a laminate (see Figure 6). There are many possibilities for the internal structure of a ply, and for how a laminate is built up. These are introduced below and in Chapter 2.

Table 2: Properties of some fibres

Property	E-glass	Carbon*	Aramid	Bamboo
Stiffness [GPa]	70-80	160-440	60-180	10-15
Breaking strength [MPa]	2400	2000-5300	3100-3600	100-200
Failure strain [%]	2.6	1-1.5	1.7	-
Density [kg/m ³]	2500-2600	1800-2000	1540	400-800
Fracture length** [km]	96	187	238	25

* There are many types of carbon fibres, and emphasis may be placed on high strength or high modulus** (see page 35).

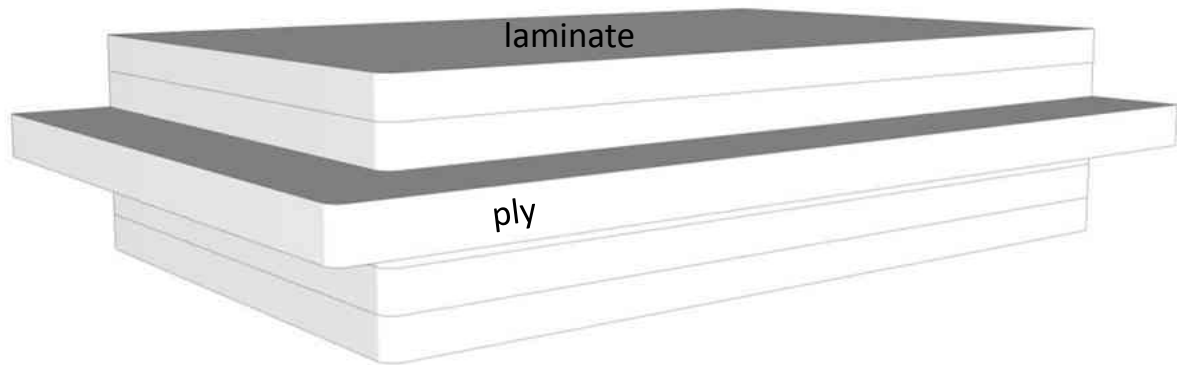

Figure 6: Definition of ply and laminate

1 - 3.6 Yarns, bundles, textiles

Fibres and fibre bundles are often not processed in a product directly but are first processed to form a textile. Except for winding and pultrusion purposes (for production methods, see Chapter 2), a textile is much more suitable than a fibre or roving (fibre bundle). The methods used for processing fibres into textiles are largely derived from the textile industry, and much of the terminology used in this field is also used in the context of processing reinforcing fibres to form textiles.

As can be seen in Figure 7, a filament (one single fibre) can be bundled to a strand (end) and directly processed to form a mat. Such a mat consists of short or long fibres that have been bonded onto each other in a more or less arbitrary pattern. This actually means it already is a composite. A short-fibre or long-fibre mat is generally called a chopped strand mat or continuous strand mat (both sometimes confusingly abbreviated to CSM). In the event

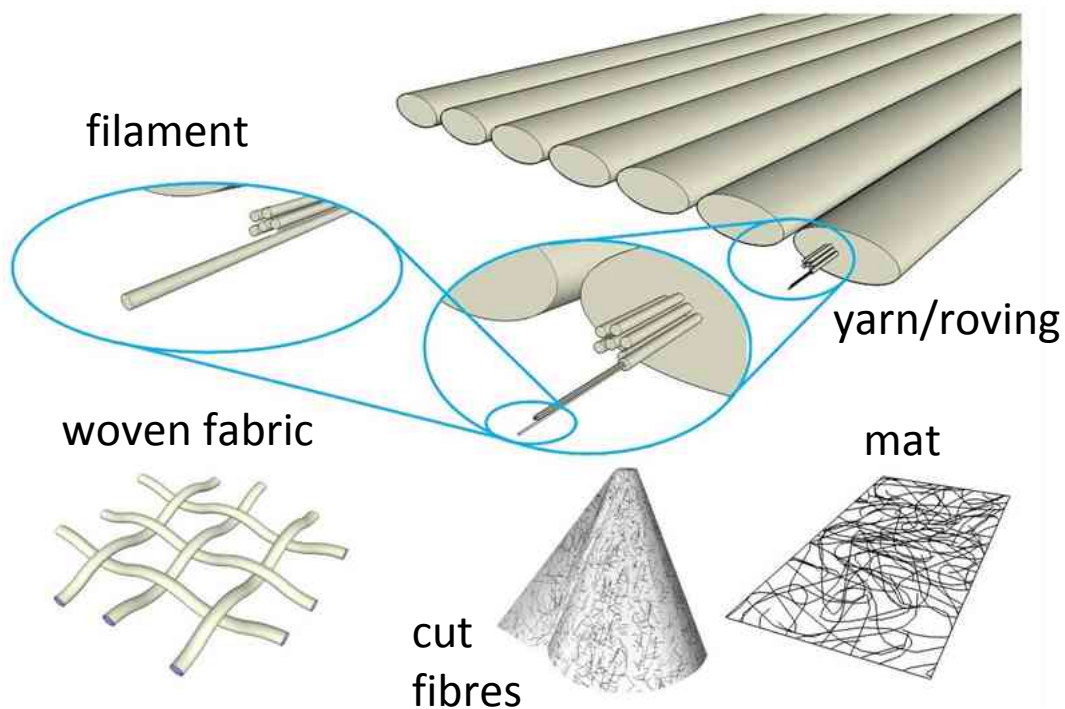

Figure 7: From Fibre to textile (based on [5])

of a very low areal weight, the term fleece is used.

The fibres can also be bundled to twisted strand to form a yarn. Untwisted strands can be combined into a roving. Two classes of reinforcing material can be made:

- Woven fabric
- Non-crimp fabric

In a woven fabric, the fibre bundles are woven. The crimp, the surface structure and the drapeability are determined by the weave pattern of warp and weft. Crimp in this context is defined as the 'curviness' of a fibre in a woven fabric that is determined by the weave pattern. Various weave patterns are shown in Figure 8.

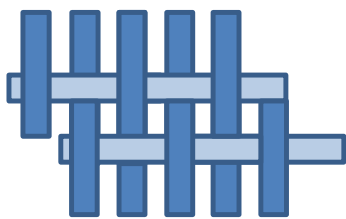

Plain weave

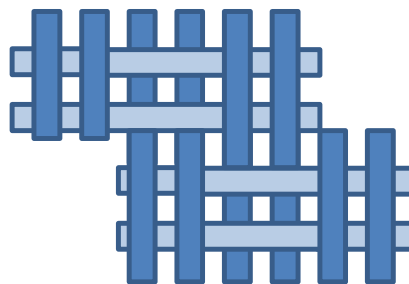

Basket weave

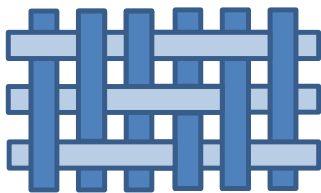

Twill weave

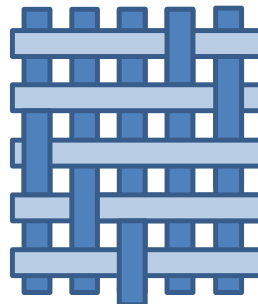

Satin weave

Figure 8: Weave patterns

The degree to which a woven fabric complies with the volume decrease of the resin during curing is related to the crimp of the woven fabric. Drapeability is related to the ease with which a textile takes on an imposed shape. The more drapeable a textile is, the less susceptible it is to creasing, and the larger the possible changes of direction the textile can have in the mould. However, this detracts from the quantity of control that you have over the direction of the fibres in the draped textile during handling. The weave has a large influence on the properties of a ply. In general, looser weaves, such as twill and satin, show better drapeability and permeability than a smooth weave, which in turn provides a more stable textile.

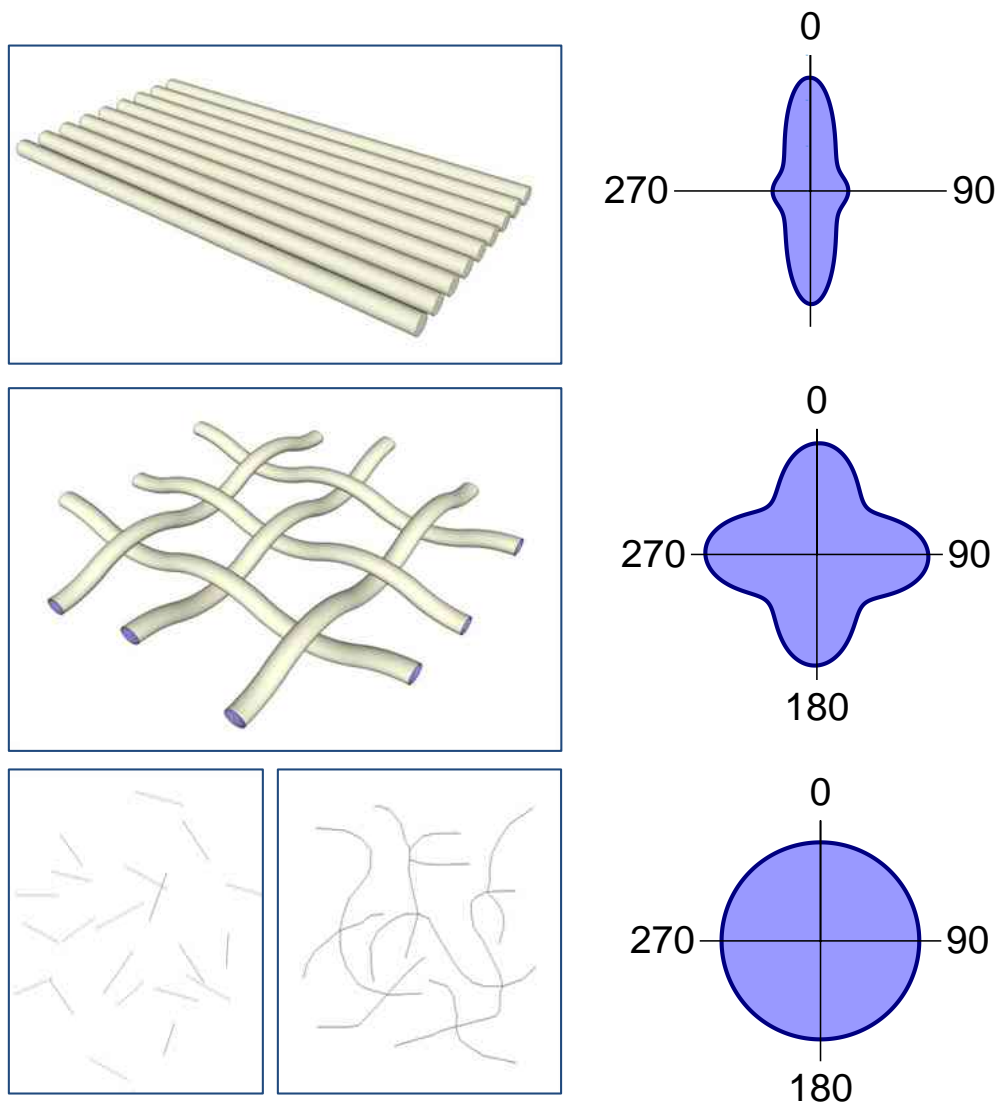

Figure 9: Polar stiffness diagram (based on [6])

The stiffness of a composite can be different in different directions due to fibre orientation. This is shown in a polar stiffness diagram, in which the stiffness in different directions is indicated as the distance from the origin to the line in the respective direction (see Figure 9).

As the name indicates, a non-crimp fabric (NCF) has no built-in crimp; all fibre bundles are straight. This is achieved by stitching the fibre bundles either to each other or to a thin support layer. The latter consists of a limited amount of fibres oriented transversally to the main direction of the textile or a thin fleece of arbitrarily oriented (cut) fibres. For this reason, non-crimp fabric is often referred to as stitched fabric (see Figure 10).

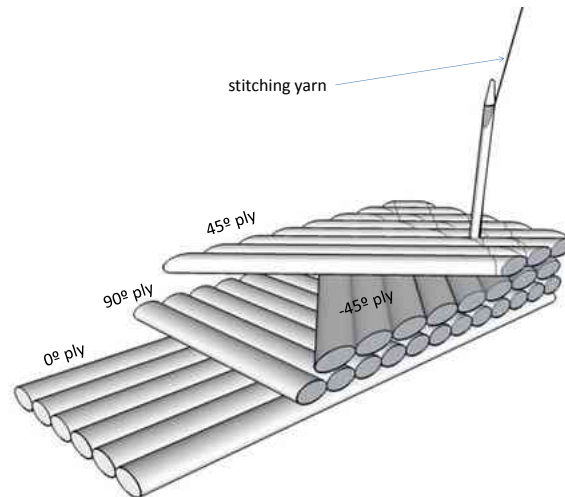

Figure 10: Production of a quasi-isotropic non-crimp fabric by stitching (based on [7])

1 - 4 Polymers

The world around us is full of polymer products. At first glance, the differences between most polymers are not obvious. But just as different wood species were used for different purposes in the past (e.g. oaks for robust furniture, tropical hardwood for window frames and sandalwood for carved images), different polymer materials are used for different purposes. For example, plastic coffee cups are made of polystyrene (as is the insulation in a refrigerator), the vacuum cleaner in a corner of your student accommodation is made of impact-resistant ABS and your water bottle is made out of inert polyethylene.

1 - 4.1 The role of polymers as a matrix in a composite

In composites, fibres are embedded in a polymer, which is called the 'matrix' (originating from the Latin word for 'womb'). It may not seem logical to partly compromise the high strength and stiffness characteristics of the fibre materials by mixing them with polymer materials. Indeed, most production techniques are at least partially based on including as little polymers to the composite as possible. The most important and most obvious reason for including the polymer is that the polymer acts as an 'adhesive' and binds the fibres together. By encapsulating a fibre with polymer, the fibre can absorb higher compressive loads; it is supported by the resin. A somewhat less obvious, but very important, function of the polymer is that the fibres can work together better, because the polymer transfers loads from one fibre to the other through shear stresses. External loads are thus better distributed over the fibres in a composite than in a dry fibre bundle. When one filament breaks, the load is distributed over the other filaments.

In addition, the polymer largely determines the sensitivity of the composite to external influences such as moisture, chemicals, and ultraviolet light. It often determines colour and surface quality, opacity, and fire safety.

In summary, the role of the polymer in a composite should not be underestimated. The term 'fibre-reinforced plastics' does not justify the role of the polymer, because the polymer itself plays a crucial role in the success of a composite material.

Isotropy

A material is isotropic with regards to a property if this property is of equal magnitude in all directions. The opposite of isotropic is anisotropic. Because of their fibre orientation, composites are virtually always anisotropic. A special case of anisotropy is 'transverse isotropy': this is often the case in carbon fibres. Another case is 'orthotropic': this is almost always the case for plies. Sometimes a composite is made as isotropic as possible: a quasi-isotropic stacking sequence is used. A quasi-isotropic laminate may have fibres in 0° , 90° , and $\pm 45^\circ$ -directions with respect to the load.

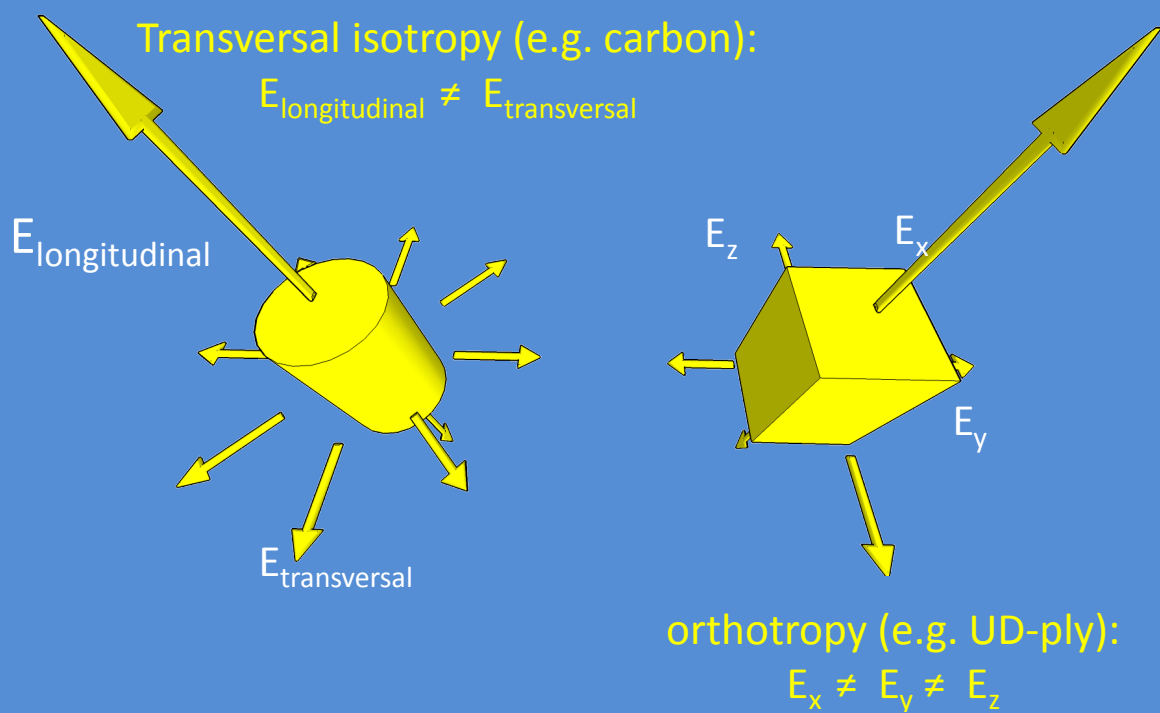

Various kinds of polymers are used in composites. The most relevant are discussed in the following sections. But first we shall classify polymers into two categories, since most of the processing methods depend on the category the polymers belong to. These categories are the thermoplastics and the thermosets.

1 - 4.2 Thermoplastics

Thermoplastics are polymers that melt upon heating, becoming formable and regain their solid shape upon cooling. Most commonly used unreinforced polymers are thermoplastics. In molecular terms, thermoplastics consist of long entangled chains. Upon heating, some freedom of movement is gained through the molecular movements.

Exceptions aside, thermoplastics are not generally suitable for impregnation of a fibre reinforcement due to their viscosity (high viscosity in liquid state, related to the molecular state). This prevents the thermoplastic from wetting the fibres adequately (impregnating), thus a good composite cannot be formed. To produce composite materials using thermoplastics, high pressures and temperatures are necessary. A commonly used method is to alternate dry plies with thermoplastic films and produce a composite by means of a heated mould (e.g. compression moulding). Alternatively, thermoplastic yarns or fibre bundles are co-spun with the fibre reinforcement. Then, a lower external pressure is needed to arrive at a good impregnation.

A recent process development is the infusion of thermoplastics. The infusion process uses monomers that polymerise during curing. Since monomers have short chains they do not get entangled, leading to a low viscosity in liquid state and making them suitable for infusion.

1 - 4.3 Thermosets

Thermosetting resins (in short: thermosets) do not melt on heating, but ultimately disintegrate. From a molecular point of view, most thermosets consist of relatively short chains ensuring the non-cured polymers to have very low viscosity (see 1 - 6). Curing is carried out by initiating a chemical reaction, in which the short chains form bonds and create a three-dimensional 'cross-linked' network. The temperature is often regulated during curing. This can also apply for the pressure (depending on the fabrication method).

The distinction between thermoplastics and thermosets is not always clear. Polyesters, which are classified as thermosets below, can also be thermoplastic. Phenolic resins behave as thermoplastics up to a particular temperature.

1 - 4.4 Different kinds of polymers

The most commonly used thermosetting plastics are polyesters, vinylesters and epoxies. A comparison of these three immediately reveals:

- Polyesters and vinylesters are cheaper to produce than epoxies.
- Epoxies shrink less during curing than polyesters and vinylesters.
- Polyesters are more sensitive to damage due to osmosis (water that is absorbed in the polymer and can cause blisters, see Chapter 3).

- All polymers require at least two components to be mixed: in the case of polyester and vinylester this is the monomer and a catalyst (and accelerator) to cure; epoxies require a hardener to be mixed with the main component.
- An exothermic reaction takes place in all systems.

Further details and finer distinctions are discussed below. General properties can be found in Table 3.

1 - 4.4.1 Polyester

Polyester composites are widely used, partly due to their low price. The material is used on a large scale in yacht building, the automobile industry, tanks and piping, and in artificial stone. In the case of polyester, the most important components have already been mixed (unsaturated polyester monomers and styrene). This means that polyester may cure inside the resin container. If you wait long enough, this will indeed happen. At room temperature, this process is very slow and can be delayed by dedicated additives (inhibitors). To obtain a workable process time, a catalyst (e.g. a peroxide) is added to the non-cured polyester (a catalyst accelerates a chemical reaction but does not take part in the reaction itself). A small percentage (by weight) is enough to initiate a reaction.

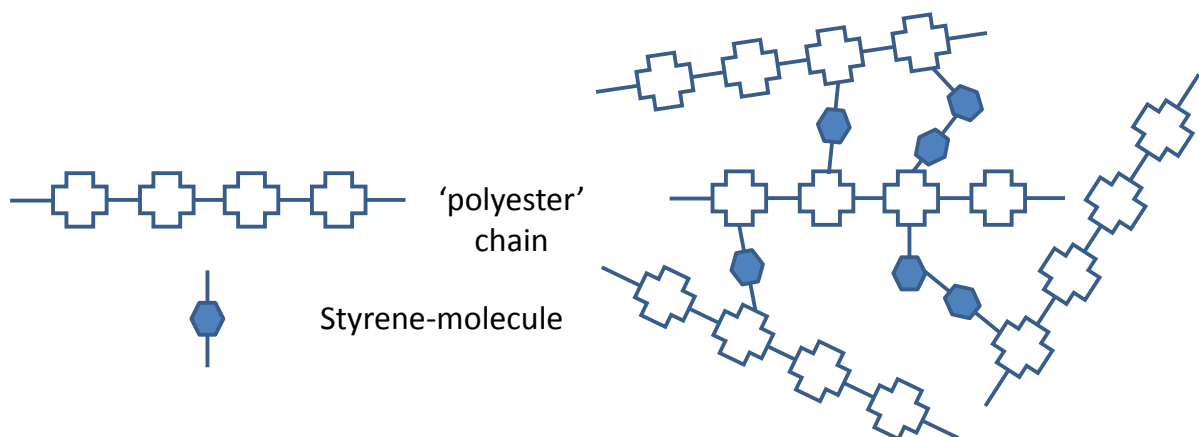

Figure 11: Schematic representation of cured polyester

The unsaturated polyester is dissolved in approx. 35% styrene (an extremely volatile solvent with a low odour threshold). During curing, this styrene forms cross-links with the unsaturated resins in the polyester chains, causing a three-dimensional structure to be formed. The largest part (>95%) of the styrene takes part in this reaction. A part of the styrene evaporates during the process (<5%). This is readily noticeable due to the low odour threshold – you can easily find a plant where polyester is processed by simply following your nose. A low styrene emission polyester resin (LSE) also exists.

The molecular chain of a polyester contains several reactive groups. A cured polyester is shown (schematically) in Figure 11.

The volatile styrene easily boils at low pressures. This means that special attention must be paid to pressure in a vacuum injection process. Traditionally, polyester has often been used in hand lamination or spray-up processes (see Chapter 2).

Polyester is sensitive to water (see Chapter 3). This sensitivity of polyester to water does not apply to all polyesters. If an isophthalic acid polyester is used (instead of ortho polyester), even moveable swimming pool floors can be produced using polyesters (see Figure 12).



Figure 12: Moveable swimming pool floor (source: Variopool)

1 - 4.4.2 Vinylester

Vinylesters are used in applications where a higher chemical resistance is required than polyesters can offer. Vinylesters are less sensitive to moisture and can be used, for example, as protective coating over polyester structures that are exposed to water. The lack of sensitivity to moisture is partly due to the relatively small portion of esters (because the monomers are slightly longer) and partly due to the type of esters located adjacent to

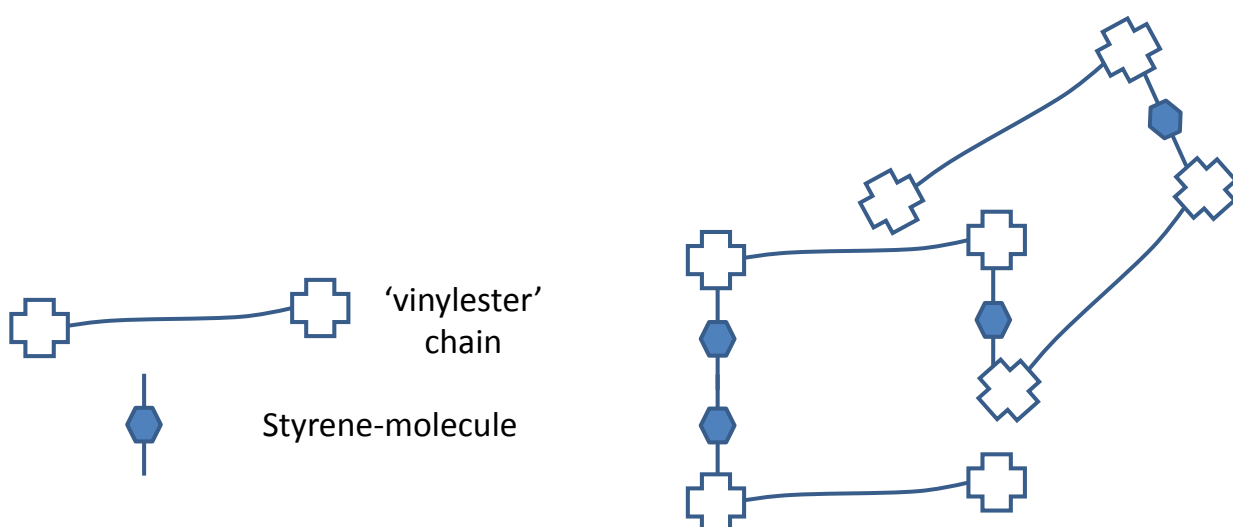

Figure 13: Schematic representation of cured vinylester

aromatic groups, so that the mechanical properties are better. This results in a somewhat tougher cured polymer, shown schematically in Figure 13. A disadvantage of vinyl esters is that they can turn yellow (due to the aromatic ether compounds). It is prudent to use a vinyl ester layer as a protective coating, but from an aesthetic point of view another layer may sometimes be applied on top of it.

1 - 4.4.3 Epoxy

Epoxy materials are more expensive and applied less often than polyesters and vinyl esters. With the rise of vacuum injection technologies their market share has risen. A large percentage of wind turbine blades is made with epoxy systems, partly because the fatigue strength of fibre-reinforced epoxy is higher than that of fibre-reinforced polyester (nevertheless, it is important to note here that an important blade manufacturer, LM Glassfiber, has a very large market share in polyester blade products).

From a chemical point of view, epoxies work differently from polyesters and vinyl esters. The polymer is formed by merging two components, often an epoxy molecule and an amine. The reaction is initiated by mixing, which results in the components (epoxy molecules and amines) forming a closed network that is more regular in structure than that of vinyl esters (see Figure 14). A number of variants exist for both components of an epoxy (Figure 14 is

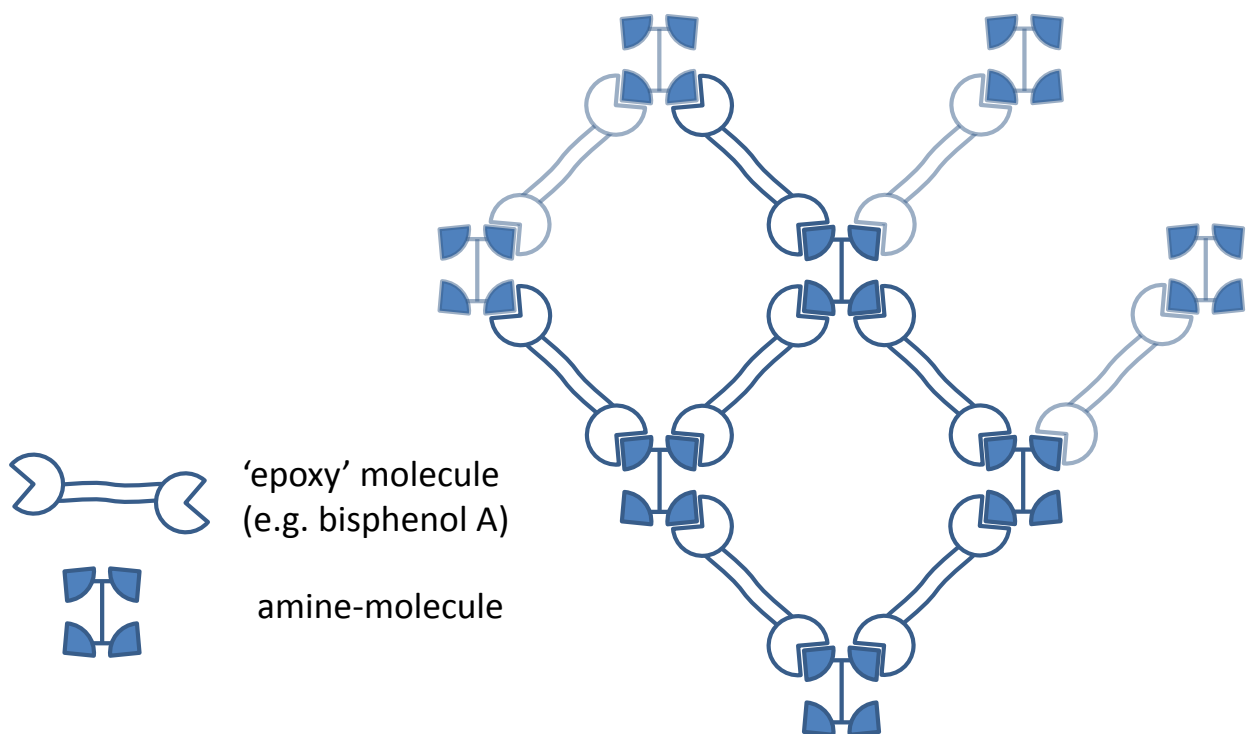

Figure 14: Schematic representation of cured epoxy

only a schematic representation).

Epoxies are also known as adhesives; many two-component adhesives are epoxy-based. Such adhesives are highly suitable for bonding metals.

The chemical composition and manufacturing method of polymers based on esters and epoxies are so different that some manufacturers specialise in a particular type. DSM, for

instance, does not manufacture epoxy resins (although the vinylesters they sell are based on epoxies).

1 - 4.4.4 Phenolic resins

Phenolic resins are thermosets that have a high glass transition temperature and good fire-safety properties when they come in contact with sparks (they scorch but do not burn or melt). For this reason, they are often found in printed circuit boards and interior parts for aircraft and trains. They are also used for bonding plywood and hardboard. Disadvantages are that they are brittle and that water is released during curing.

1 - 4.5 Material properties

Table 3 shows some material properties of polymers. The exact properties depend on the chemical composition of the polymers. The circumstances during curing also play a role (for example, see 1 - 5). Note that the elongation at failure and the ultimate strength of resins play a limited role in most composite structures. In a heavily loaded component, many fibres will lie in the load direction. Since the elongation at fibre break is often lower,

Table 3: Resin properties

Property	Polyester	Vinylester	Epoxy
Stiffness [GPa]	2.4-4.6	3-3.5	3.5
Ultimate strength [MPa]	40-85	50-80	60-80
Ultimate strain [%]	1.2-4.5	5	3-5
Density [kg/m ³]	1150-1250	1150-1250	1150-1200
Curing shrinkage [%]	6-8	5-7	<2

resins will stretch up to the fibre breaking point. The ultimate strength of fibres is much higher, however, and since the fibres are more rigid than the resins, they will absorb most of the stress.

The toughness of the resins (not listed in the table) plays an important role, particularly with regard to impact and fatigue (see Chapter 3).

Shrinkage is also very important. Upon a large 'curing shrinkage', a composite ply will shrink more in the transverse fibre direction than in fibre direction. In the event of an asymmetrical laminate structure, this can cause undesired curing deformation (see also Chapter 3). 'Shrinkage stresses' or 'residual stresses' occur in a ply and laminate due to uneven shrinkage during curing. This happens because the resin shrinks, but the fibres do not. Bear in mind that epoxy resins shrink more in volume during curing than the value specified in the table (approximately 5%). Subject to a different curing mechanism, an epoxy will shrink to a large extent when it is still liquid, so that there is a smaller effect on residual stresses. This may explain why an epoxy composite has relatively good fatigue properties.

1 - 5 Glass transition temperature

The glass transition temperature (T_g) is the temperature at which a resin passes from the 'glassy' state (rigid and brittle, i.e. little plastic deformation at fracture) to the 'rubbery' state (slack and tough). It is not recommended to use a composite in the vicinity of or above this temperature. The effect of exceeding the glass transition temperature is much stronger with thermoplastics than with thermosets, but is reduced for both by the reinforcing material.

The glass transition temperature depends on the circumstances during curing (for thermosets). A higher glass transition temperature can be achieved by curing at higher temperatures and with longer periods of heating.

1 - 6 Viscosity and permeability

To better understand the infusion process of composites and to be able to determine the 'infusion strategy' (see Vacuum technologies), knowledge of the viscosity of non-cured matrix materials is important, as well as knowledge of the permeability of the reinforcing material. Calculations of infusion are based on Darcy's law:

$$Q = \frac{K \Delta p}{\mu \Delta x}$$

With:

Q	=	Volume flow [m/s] through a reference surface
K	=	Permeability [m ²]
μ	=	Viscosity [Pa s]
Δp	=	Differential pressure [Pa]
Δx	=	Infusion length [m]

Here, viscosity reappears (the thicker the substance, the higher the viscosity), as well as permeability (the higher the value, the more permeable a substance is). The differential pressure per unit of infusion length is also important. The formula shows that the lower the viscosity and the higher pressure and permeability, the greater the volume that can flow through a particular cross-section, A, of a medium and the shorter the infusion time. This formula is used in all branches of science, particularly in geosciences (to describe groundwater and oil flows through rock).

The permeability of a reinforcing material does usually not change during infusion. But the permeability of the fibre package (the 'dry' laminate) may be influenced, for example, when the fibre package is pressed (and the permeability is lowered) with a one-sided mould. During the curing process, the resin shows a large variation in viscosity – ideally from 'watery' to 'hard'. Often, part of the curing already takes place during infusion. This should be taken into account when designing the process.

Calculation example: infusion and Darcy's law

Let's look at a simple case of a thin, rectangular laminate which is infused in a double-sided mould using a vacuum, see the figure below. Dimensions and relevant material properties are in the table below.

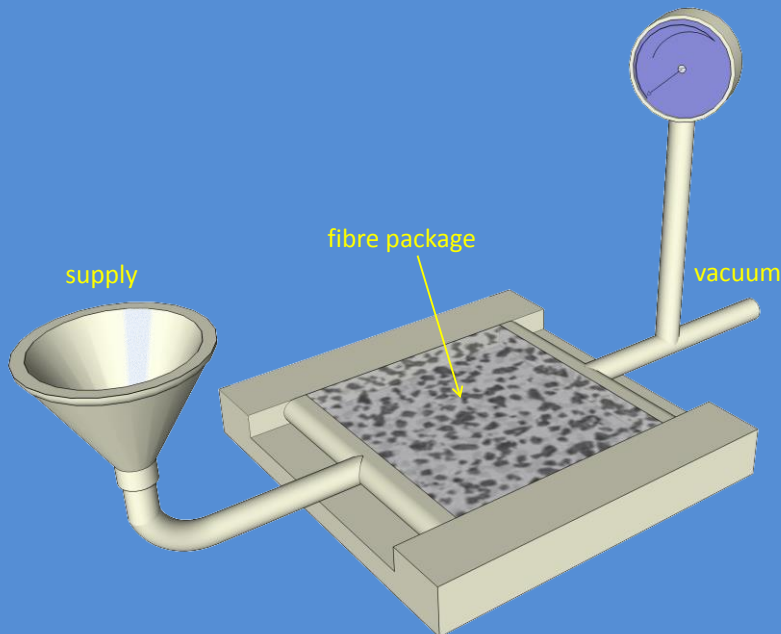

Parameter	Value
Permeability K [m^2]	$50 \cdot 10^{-12}$
Differential pressure ΔP [Pa]	1
Dynamic viscosity μ [Pa·s]	10^{-5}
Infusion length Δx [m]	0.1

Substitution in Darcy's law yields an infusion time of approximately half an hour for one metre mould length. If the resin would have been supplied from the centre of the mould instead of from the edge, the infusion time would be halved in this (one-dimensional) configuration.

The viscosity in the above formula is a function of time and temperature. In the case of thermosets, the higher the temperature, the faster the curing (and corresponding increase in viscosity). This is sometimes complicated by the fact that the curing of thermosets involves an exothermic reaction in which heat is generated. If there are limits to the rate at which this heat can be removed (e.g. because of the surrounding laminate, an insulating

mould, or in sandwich materials), the temperature will rise and curing will be faster, causing the temperature to rise further. This is a self-reinforcing process.

Knowledge of the progress of the permeability and viscosity and the geometry of the product is essential to determine the infusion strategy (e.g. for injection techniques). This is discussed further in Chapter 2.

1 - 7 Sizing

In the manufacture of fibre materials, a thin film is applied around the fibre. This film contains chemicals that, amongst other things, ensure that the fibre adheres well to the resin. The film forms the interface between the fibre and the resin. Typically, it is approximately 0.5% of the weight of the fibre. Since different resins have different chemical compositions, sizing is adapted to a specific resin. A good adhesion between fibre and resin is important for the properties of a composite. In addition to the different configurations of fibre materials (woven fabric, mat, etc.), care should be taken in choosing a reinforcement product and resin to ensure good adhesion.

1 - 8 Sandwich and core materials

Sandwich materials make up a special category of composites. They generally consist of two skins and a core material between them. Sandwich structures are often applied in lightweight structures. The structural aspects of a sandwich are discussed in Chapter 4.

A selection can be made from a wide range of materials for both the skins and the core. A few options for core material are discussed here.

Cores of sandwiches can consist of honeycomb structures, (balsa) wood and polymer foam. For sandwich materials, it is important that the choice of material and the method of bonding to the skins leads to a strong compound. A polystyrene foam, for example, would be sensitive to the solvents that are used in many adhesives.

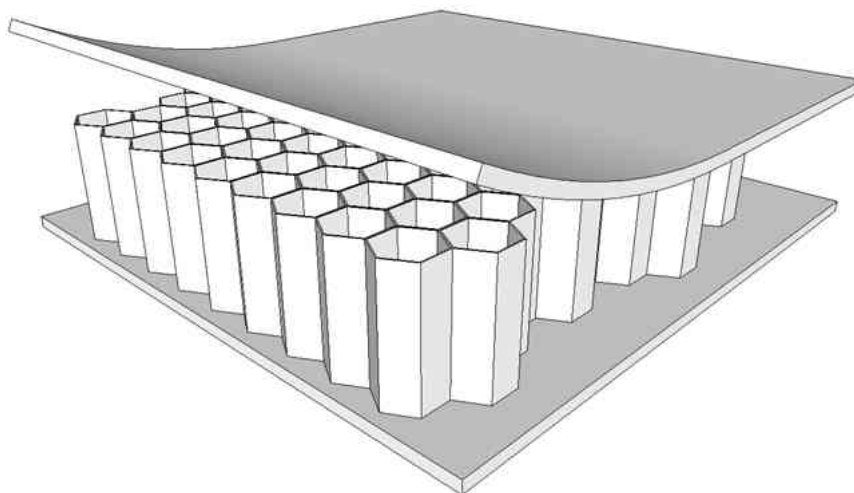

Figure 15: Sandwich material using honeycomb core

Honeycomb structures (Figure 15) are applied extensively in aerospace structures. Honeycombs are relatively expensive. Balsa wood is cheaper and has a good stiffness-to-weight ratio. Since it is a natural material, mechanical properties may vary, it can rot, and is available to a limited extent only. Polymer foams are widely used. They are available in various kinds of polymers and standard densities. Core materials are available as sheet material. For application in curved or double-curved surfaces, the materials are adhesively bonded as blocks on a fibre cloth or provided with grooves in one or two directions (fully or partially cut through the thickness). This allows for bending or draping the plies of core material (see Figure 16).

Joining a skin and a core can be done in advance by bonding. It is possible to join skins and cores in vacuum infusion. Upon impregnation of the skins and the outermost layer of the core, the bond between skin and core is made using resin. In this case, it is necessary to take into account absorption of the resin by the core as well as the chemical compatibility of the core and the resin. Considerable quantities of resin can flow in the core grooves described above. This may result in unnecessary weight increase of the product.



Figure 16: Core material with grooves (source: WMC)

Breaking length

The breaking length is a material property which indicates the ratio of strength and density. A large breaking length is especially useful for applications that are (partially) loaded by their own mass, such as aircraft, long bridges or, somewhat more exotic, space elevators. The tensile stress in the cross-section is:

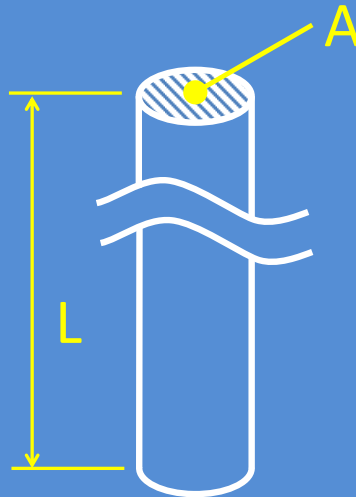

$$\sigma = \frac{F}{A} = \frac{mg}{A} = \frac{L\rho g}{A}$$

Where F is the force exerted by the free-hanging part, m is the mass of the free-hanging part, g the gravitational acceleration, and ρ the density. If this stress is equal to breaking stress, the length is equal to:

$$L = \frac{\sigma}{\rho g}$$

This is called breaking length, which is closely related to specific strength ($\sigma_{\text{failure}}/\rho$).

1 - 9 Sources

- [1] www.netcarshow.com/chevrolet/1953-corvette_c1
- [2] Vereniging Kunststof Composiet Nederland, 'Kunststof composieten, een kennismaking' (Fibre reinforced composites, an introduction), and 'Materialen en materiaaleigenschappen' (materials and material properties), factsheets about designs with composites, parts 1 and 5, via www.vkcn.nl
- [3] CES Edupack, GRANTA Design
- [4] VKCN – Poly Products B.V. opvouwbare zeecontainer Cargoshell (foldable sea container), (www.vkcn.nl)
- [5] Engineering Materials, properties and selection, K.G. Budinski en M.K. Budinski, Pearson, New Jersey, negende druk 2010
- [6] R. van de Ven, Composietmaterialen (Composites), Stam Techniek, 1993, ISBN 90-401-0073-X, (Figure 5.9)
- [7] SP Guide to Composites, from www.spsystems.com

1 - 10 Exercises for this chapter

- 1) *What is the definition of a composite?*
- 2) *Name three advantages of composites.*
- 3) *Name three disadvantages of composites.*
- 4) *What is the function of fibres in a composite?*
- 5) *Name three kinds of fibres.*
- 6) *What is the function of polymer in a composite?*
- 7) *What is meant by a ply in a laminate?*
- 8) *In which two categories – both very relevant for the processing method – are polymers divided?*

Already at an early age we learn that there are various construction methods. The performance (look, cost, strength, functionality) depends on design, materials and the available tools. Some results can be achieved with one method and not with the other...

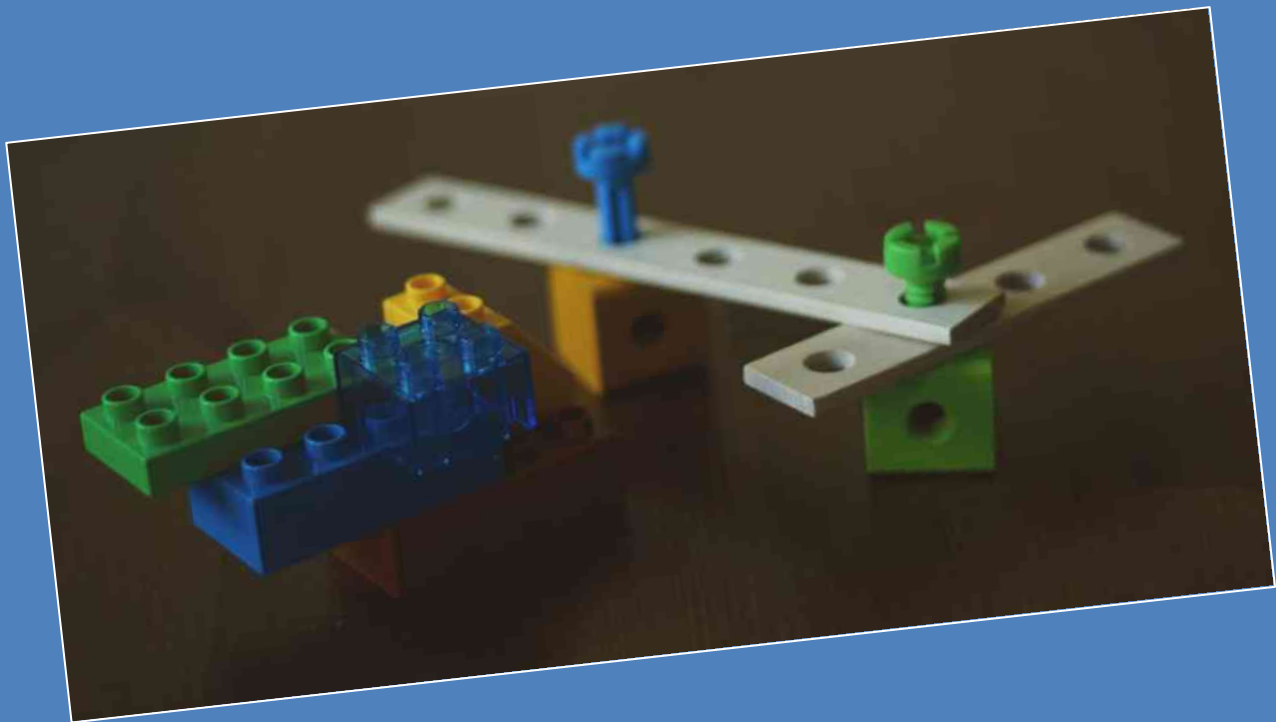

Chapter 2

Production methods

After studying this chapter you will be familiar with the most important techniques and associated aids for processing fibres and resins into a composite structure. You will be able to make an educated choice for a specific application.

When manufacturing a composite material, the material and the structure are often made in a single process. This is related to the use of the polymer, since it cures during the process and is then no longer deformable.

2 - 1 Moulds and plugs

To ensure that a product is made in the correct shape, production methods of composites are often based on the use of moulds. The mould is often not highlighted in the discussion of production methods, but is important for the quality of the product. Often it makes up a significant proportion of the costs. For large products, the dimensional stability is important. This implies that a stiff mould structure is necessary to retain its geometry over a large temperature range. For large series, the mould must be capable of withstanding wear. Most resin systems form good adhesive bonds in the cured state. This means that the mould must be provided with a release layer before starting the production process. To this end wax, PVA (polyvinyl alcohol) or Teflon tape, for example, are used.

In modern production processes, the mould is provided with all kinds of sensors (temperature, pressure) that monitor and register the state of the process (for example, for the quality system of the producer).

In some cases, a direct mould can be used. The direct mould is a negative cast of the product. The easier the product can be released from the mould by its geometry and/or application of a release agent, the more products can be made from it (i.e. the larger the 'service life').

In other cases, to manufacture a mould, it is necessary to first make a positive 1-to-1 model (the 'plug'). The plug is then used to manufacture a high-quality composite mould. This can take place when an object is copied. Take a ship, for example, of which a series is to be made. In this case a 'cast' can be made of the ship's hull (a direct mould), which can then be used to manufacture a new ship hull. The original ship hull is then referred to as the plug. Sometimes a plug is produced first (for example, using numerical machining equipment). The plug is then used to produce a mould in which a ship's hull is laminated. This apparently laborious method is used to ensure that the geometry and the finishing of the final product on



Figure 17: Mould for a 52m wind turbine blade (source: Bright Composites)

the visible side are according to specifications. Making a mould in the shape of the inner wall of a ship and laminating the ship's skin over it can lead to an unsatisfactory result. Additionally, the installation of other structural elements in the ship and the finishing process can become complicated. The direct mould or plug can be made of the original object, but can also be a simple MDF (Medium-Density Fibreboard) or EPS (Expanded PolyStyrene) mould with model paste, or a higher-quality CNC-milled foam mould with model/tooling paste.

When making a mould and/or plug, the following should be taken into consideration:

Release: the product must ultimately be releasable from the mould. The sides of the mould must make an angle of at least 1 to 2 degrees with respect to the direction of release, without confining the product in the mould. When a product is not releasable but should still be made as a single part, the mould can be provided with an insert. The insert can be taken from the mould before release or loosened from the mould and released with the product.

Flanges: it is recommended to leave a 'production flange' around the final product. The mould is made somewhat larger than the product so that sufficient space is left around the product to insert aids, e.g. for the application of vacuum techniques. This allows space to finish the edges of the product after release. For non-releasing products, the mould is sometimes made in parts. In this case, part flanges can be used.

The mould and/or plug play a large role in achieving a good release, desired service life, good appearance and gloss of the product, deformation of the product after release (shrinkage stresses) and of course the geometry and tolerances of the product. In the

(integral) design of a structure, special attention should be paid to the design of any moulds and plugs that are to be used.

2 - 2 Categories of production methods

Production methods can be chosen on the basis of various criteria. A few examples:

- Suitable for single piece or serial production
- Temperature
- Pressure
- Cure rate
- Desired surface quality
- Initial materials
- Quantity and type of required tools
- Costs (a function of the above criteria)

As the material and the product are made in a single step, the quality of the end product is determined to a large extent by the method of production. Manufacturing tools also determine the success of a composite product. For each product, an optimum can be found between investment in knowledge and tools and functionality. Choosing (a combination of) production technologies is one of the most challenging aspects of constructing with composite materials. Especially since there are production processes that are still under development or have yet to be developed.

In the following section, raw materials and aiding materials are discussed, followed by an overview of the most current processes.

2 - 2.1 Raw materials

During the design process and when selecting a processing method, a number of choices must be made with regard to the fibre reinforcement. The main options are:

- Bobbins with fibre strands or yarns
- Woven fabrics
- NCFs
- Mats with different combinations of fibre orientations

In the initial engineering stages, modifications of the manufacturing process may be implemented. For example, fibre bundles can be braided, or chopped during the process to obtain short fibres.

In addition to the separate resin and fibre components, it is also possible to order pre-impregnated materials, so-called 'pre-pregs'. These are fibre reinforcements that are pre-impregnated with a resin system that is not yet completely cured. The execution of a prescribed temperature (and sometimes also pressure) cycle completes the curing process. Pre-pregs (which must be stored at approximately -18°C) are slightly tacky at room temperature. This must be taken into account during manufacturing: once layers have been positioned, they do not shift easily (which can be either helpful or a hindrance, depending on the situation).

For thermoplastic composites, similar materials are available where fibre reinforcement and thermoplastic are interconnected to a larger or lesser extent. The material is consolidated by heating.

2 - 2.2 Aiding materials and devices

In addition to protective materials when working with composites and their constituents, pressure and temperature are the most important tools for composite processing.

For example, by manipulation of the pressure on a resin or a composite that has not yet cured, the probability of gas formation can be lowered. A still liquid resin system can be 'degassed' by subjecting it to low pressure. Due to the lower pressure, the volatile constituents will start boiling and are removed from the resin system. During infusion, the pressure can be used to transport resin and to impregnate fibre reinforcement. After impregnation, high pressure can be used to remove excess resin and to reduce gas inclusions that may have developed during processing. Relatively simple pumps are available for the application of vacuum or high pressure.

In addition, it may be necessary to pack the product completely air-tight in order to maintain differential pressure. Various films, seal tapes ('tacky tape'), seal rings, etc. are commercially available to make a product space air-tight. Tools exist for detecting possible leaks.

During the manufacturing process, both the viscosity of many resins and the reaction rate of the resin system are heavily dependent on temperature. To improve wetting of the fibres, some resin systems may be heated before impregnation so that their consistency becomes like that of water. Accurate heating of the mould can ensure complete and timely curing of the whole product.

Heating can be done in an oven or an autoclave (an oven which can be pressurized). For small products or repairs, electrical heating mats, or infrared heating elements can be used.

When working with composites, a variety of other tools are necessary. Important tools are scissors, cutting wheels, electrical knives and 2D CAD /CAM cutting machines etc. for cutting textiles to measure.

The preparation of the resin system, for example with epoxy resins, often requires two components to be mixed. Manufacturers specify the mixing ratio in a mass ratio, for example 100:30 (mix 100 weight units of component A with 30 weight units of component B). This requires a weighing scale. Automated mixing systems that can supply a continuous flow of resin with the correct mixing ratio are commercially available.

A large number of more or less automated methods are available for the application of fibres and resin in the mould. An example of this is a laser system that projects the

contours on the mould per ply, so that the (automatically cut) plies can be laid in place accurately by hand. Automated systems use robotic arms to replace manual operations.

2 - 3 Processing methods

The following sections provide an overview of fairly widely used techniques. They can be classified as open and closed-mould technologies. This distinction is somewhat arbitrary and certainly not exclusive. It is quite possible to make products using a combination of techniques (for example, dry winding and subsequent impregnation under vacuum).

2 - 3.1 Open-mould processes for thermosets

Open-mould processes involve a mould on which the product is made and that is not covered by a second mould or vacuum film (i.e. a flexible second mould) during the impregnation process. Closed-mould processes are described further on in this chapter. In open-mould processes, it is not possible to manipulate the pressure while wetting the fibres (impregnation). The emission of volatile substances is generally larger and less controllable than in closed-mould processes.

It is possible to start a manufacturing process as an open-mould process, and subsequently cover the product before curing and apply an over- or under-pressure to reduce superfluous resin or air inclusions (voids).

Open-mould processes are not necessarily less high-tech than closed-mould processes. In principle, laser-consolidated thermoplastic winding is also an open-mould process. But the two most common open-mould processes are almost the simplest production methods available: spray-up and hand lay-up.

2 - 3.1.1 Spray-up

Spray-up (Figure 18) is carried out using a dedicated spray pistol to apply a mixture of short fibres and resin onto a mould. The fibre direction is more or less random. The thickness is controlled by the duration of spraying a particular location. This technique is generally used for large objects or to provide a coating for construction, marine or civil engineering applications.

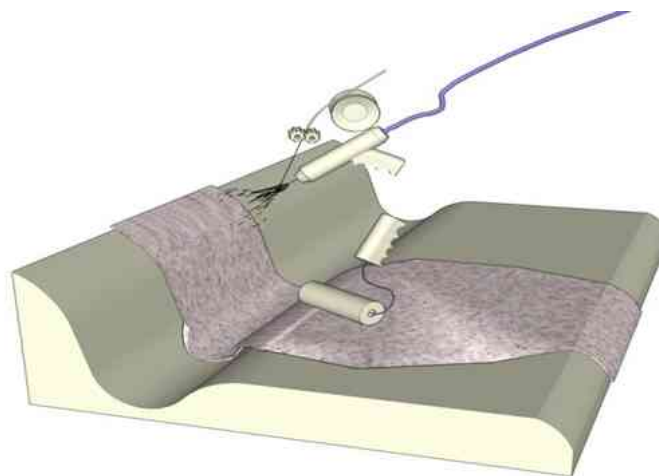

Figure 18: Spray-up

2 - 3.1.2 Hand lay-up

Hand lay-up (Figure 19) is carried out by manually applying loose plies onto a mould, and then wetting them with a roller or brush. This is a labour-intensive process, requiring measures to prevent the plies from shifting.

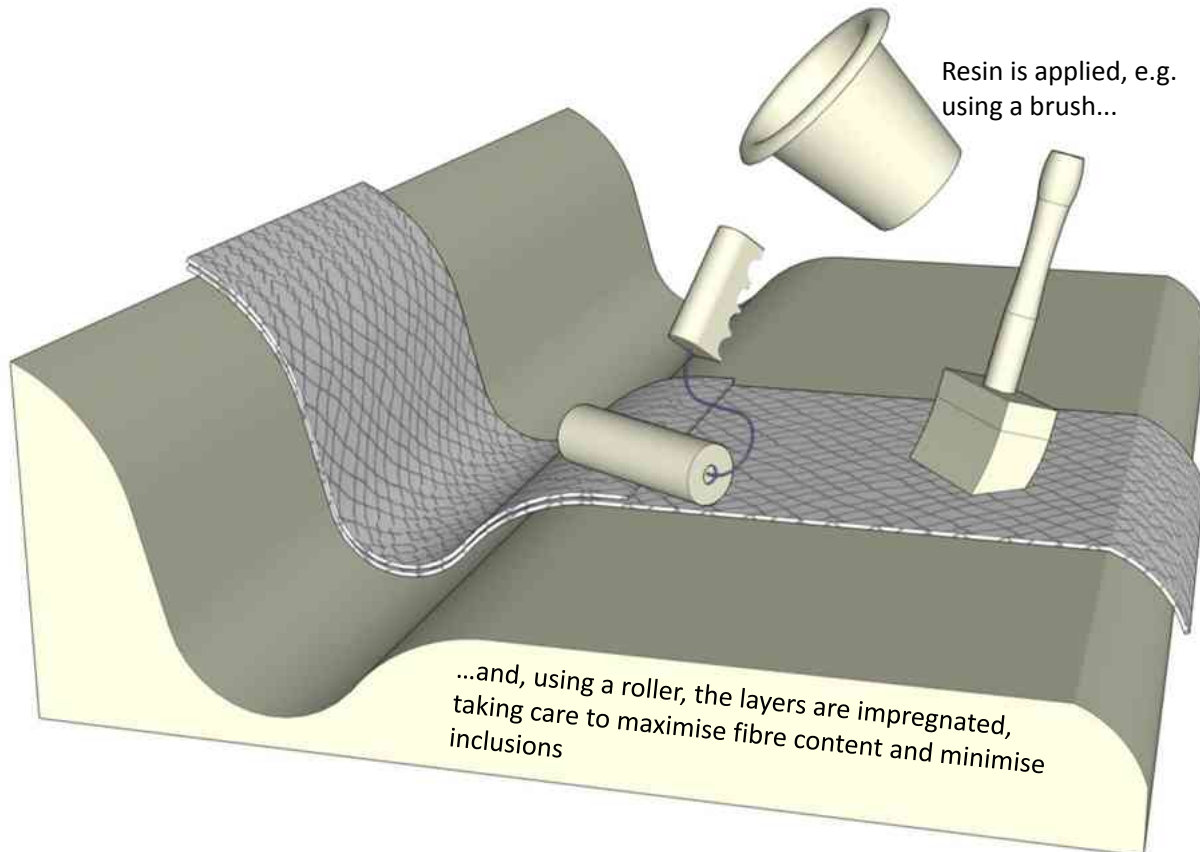

Figure 19: Hand lay-up

It is a cost-effective process since it requires only simple tools and a small number of consumables.

2 - 3.1.3 Filament winding

Filament winding (Figure 20) is an application-specific production process suitable for making cylindrical containers such as pressure vessels. Filament winding offers the possibility to orientate the fibres, providing significant weight advantages (see also Pressure vessels).

In the case of pressure vessels, the liquid/gas-tight inner layer (liner) is often used as the mould. It can be problematic to remove the mould in the case of filament winding. Soluble moulds also exist.

2 - 3.1.4 Fibre placement

The standard practice in fibre placement techniques is to use a pre-preg or thermoplastic tape or fibre bundle. This is laid in the mould by a computer-controlled robot, without manual labour. An advantage of this method is that fibres can be oriented in

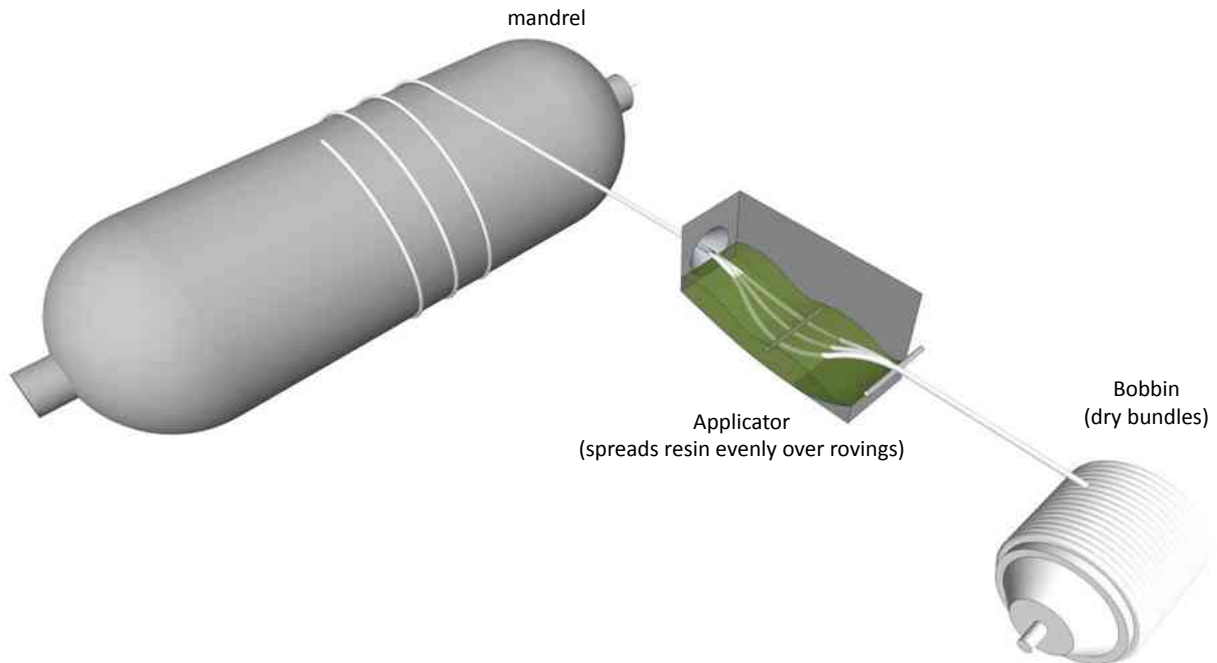

Figure 20: Winding

various directions within the plane. This is difficult to achieve with other methods and almost impossible without automation.

2 - 3.1.5 Pultrusion

The term 'pultrusion' (Figure 21 and 22) is a combination of the verb 'to pull' and the noun 'extrusion'. Extrusion is used widely to produce profiles. In extrusion processes, the material is compressed by a mould in the shape of the profile cross-section. A fibre-reinforced material cannot be pushed through a mould easily. In pultrusion, the raw material is therefore pulled through the mould. The raw material consists of a combination of fibre bundles and fibre mats (Continuous Strand Mat), which are led through a resin bath and then through the mould.

The profile is cured at high temperatures (approximately 130°C) in the mould and then generally sawn off at a particular standard length. In principle it is possible to make infinitely long profiles, but in practice pultrusion is a semi-continuous process in which the profiles are sawn to length.

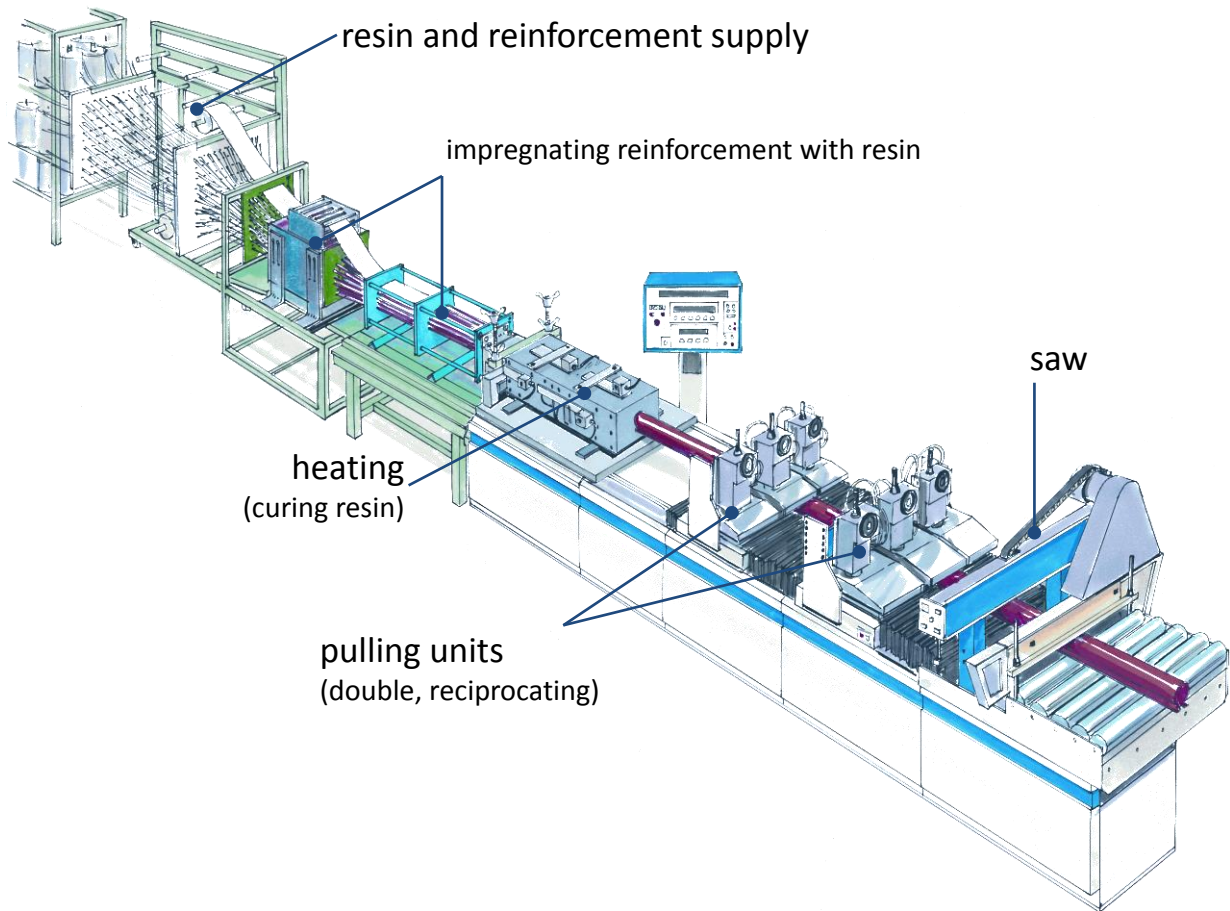

Figure 21: Pultrusion machine



Figure 22: Pultrusion is pre-eminently suitable for the production of various profiles [2, 3]

Pressure vessels

A pressure vessel is a special application where composites offer the potential of large weight savings. To understand this, knowledge of the pressure vessel formulas is prerequisite.

For a cylindrical pressure vessel with internal pressure p , the longitudinal stress is given by:

$$\sigma_{longitudinal}\pi Dt = p\frac{\pi D^2}{4}$$

This makes sense, since the force exerted on the circular rim in the figure below is balanced by the force on the bulkhead (not shown), of which the projected surface area is equal to the area of the circle (for simplicity, the wall thickness is assumed to be small relative to the diameter). After simplification:

$$\sigma_{longitudinal} = p\frac{D}{4t}$$

For the circumferential stress, the force on the straight rim is balanced by the pressure on the cylinder half:

$$\sigma_{circumferential}2tL = pLD$$

or:

$$\sigma_{circumferential} = \frac{pD}{2t}$$

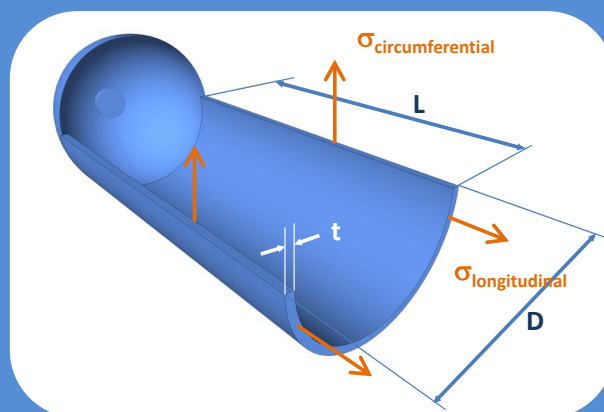

This derivation shows, that in the cylindrical part of a pressure vessel manufactured of an isotropic material, the circumferential stress is twice the longitudinal stress.

By manufacturing a pressure vessel out of a fibrous material instead of an isotropic material, the local strength can be adapted to the load. For pressure vessels made of steel wire, application of twice as much material in circumferential (hoop wound) direction compared to in longitudinal direction may result in a weight saving of 25% (assuming that steel wire has the same strength as steel sheet material).

Taking it one step further, and replacing the steel with glass or carbon fibres in a polymer matrix, and assuming that the composite strength is equal to the steel strength, the weight can be reduced by a factor of approximately 4 (going from a density of ca. 8kg/litre to 2kg/litre).

The tensile strength of UD-composites often is significantly higher than steel strength. The ratio of the composite tensile strength to that of steel is proportional to an additional weight saving; less material is needed if it is stronger. Assuming this ratio to be 2 (composite is twice the strength of steel), then a pressure vessel suitable for an equivalent internal pressure can be made approximately 10 times lighter ($0.75 \cdot 0.25 \cdot 0.5 = 0.1$). Any influence of deviating stiffness is disregarded here.

Netting theory

Since we now know that the circumferential stress is twice the longitudinal stress:

$$\sigma_o = 2\sigma_l$$

What would be the optimal fibre angle to carry both the circumferential and longitudinal stresses in the walls of a pressure vessel made out of fibres? If we decompose the force F in a fibre at an angle θ with respect to the longitudinal direction, in a longitudinal and circumferential component, and divide by the associated fibre cross-sectional surfaces in longitudinal and circumferential directions, we can rewrite the above:

$$\frac{F \sin \theta}{A / \sin \theta} = 2 \frac{F \cos \theta}{A / \cos \theta}$$

After some algebra we find the optimal fibre angle:

$$\theta = \arctan \sqrt{2} \sim 54.75^\circ$$

A major assumption here is that the fibre is the only load-bearing element and the matrix does not play any role in this regard. This is a basic assumption in a calculation method called 'netting theory', which does not consider the matrix material in composite calculations.

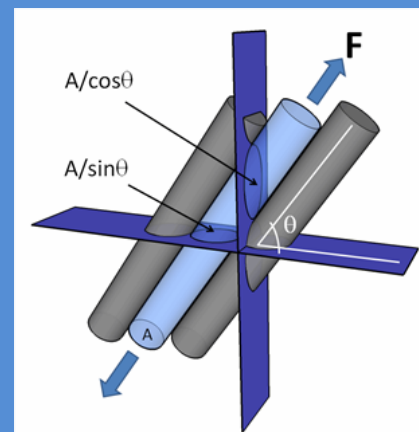

2 - 3.2 Closed-mould processes

2 - 3.2.1 Vacuum processes

Many processes can be characterised as vacuum processes, such as '(VA)RTM' (Vacuum-Assisted Resin Transfer Moulding) or SCRIMP (Seeman's Composite Resin Infusion Moulding Process). These processes have in common that the workpiece is impregnated using atmospheric pressure. This can only be done if the workpiece is closed off in an air-tight manner and air is extracted by a vacuum pump.

You can make a workpiece air-tight using a piece of plastic (vacuum film). The workpiece must then be supported on one side by a mould to avoid it being compressed in its plane (creasing). A rigid lower and upper mould can be used, making it easier to obtain the correct fibre content and provide a good surface quality on both product sides. A suitable application is the production of test specimens for material tests (see Chapter 7). The principle of a vacuum process is fairly simple, the product quality is good and large products and reasonably large series can be made.

2 - 3.2.2 Aids for vacuum processes

Figure 23 shows a typical vacuum infusion-set-up with the associated aids.

When a mould is used in the shape of the end product, a release layer should first be applied. This allows the product to be taken out of the mould after curing (most resins are excellent adhesives!). Then the laminate is built up according to the specifications. In the

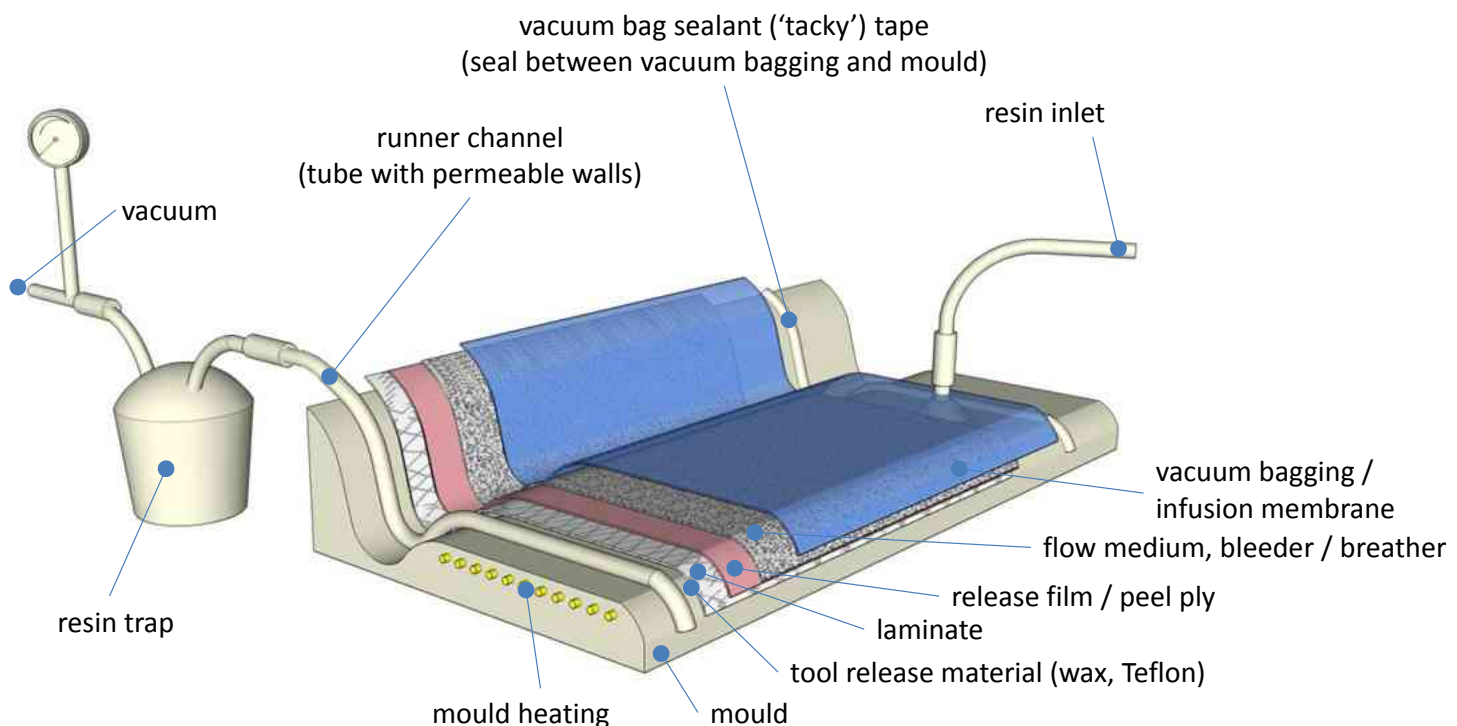

Figure 23: Aids for vacuum processes

case of one-sided moulds, a 'peel ply/release film' is often used. This too is a kind of release layer, but also ensures that the final surface structure obtains a particular roughness (which is favourable for bonding, for example). Sometimes a cloth or gauze, known as a bleeder/breather fabric is laid over a part of the product, ensuring that the resin can proliferate throughout the product before curing. Finally the whole stack is sealed with vacuum film. This is pasted around the product on the mould using a kneadable and very sticky vacuum bag sealant tape called 'tacky tape'. The tacky tape is not applied to the release layer.

In general the film is not stretched tight over the mould, but is left with some creasing in it so it can handle deformations during the process. Once the set-up is air-tight, vacuum is applied at one or several points. This results in resin being sucked into the product. To prevent superfluous resin running into the pressure gauge or vacuum system at the vacuum side, a resin trap is often placed at the discharge side.

2 - 3.2.3 Infusion strategy

Prior to infusion, the connection locations of the resin feed and the air discharge on the product must be selected carefully. To a large extent, these determine the 'infusion strategy'. If a wrong infusion strategy is chosen, the following two problems are most likely to occur:

- Incomplete infusion through an **excessively long infusion path**: During infusion, the resin becomes tackier and will flow increasingly slower through the product. If infusion paths (i.e. the distances between supply and discharge points) are too long, the resin will not be able to proliferate throughout the product.
- Incomplete infusion through **incorrect preferred path**: The resin will follow the path of least resistance between supply and discharge points. It will tend to follow

the flow-medium (e.g. the bleeder/breather fabric mentioned above) instead of the fibre package if the latter (which is less easily transmissible for resin) is covered by bleeder/breather over the whole infusion path (which is easily transmissible for resin). This is also the case when resin feed lines (runners) run too far into the set-up; in this case, 'racetracking' may occur, with dry spots arising midway between the supply pipes.

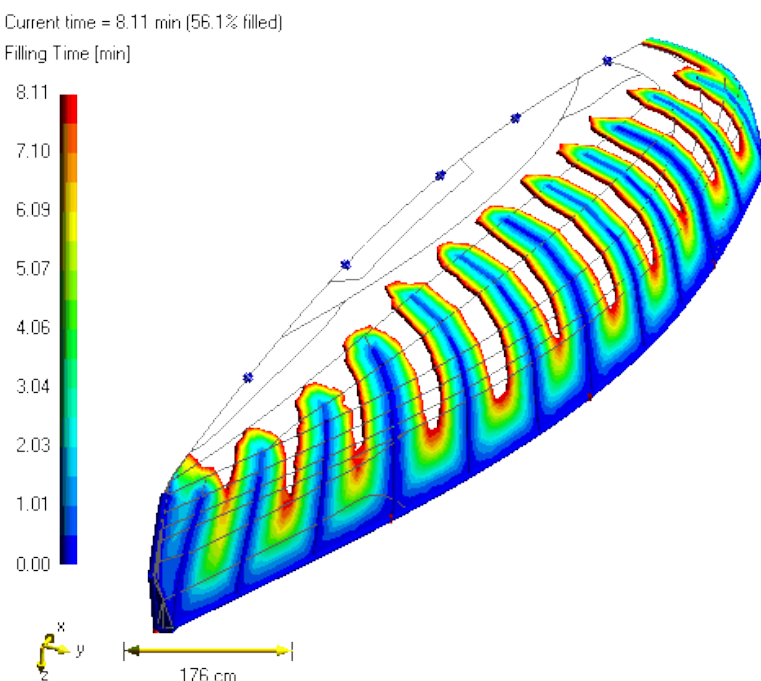

Figure 24: Simulation of infusion process [4]

Software based on a combination of the finite element method and Darcy's law (see Chapter 1) is available with which infusion strategies can be designed. On the

basis of the predicted infusion time, production time can be estimated and possibly improved. Figure 24 shows an example of a simulation of an infusion. For more information on design software, see [5].

2 - 3.2.4 Autoclave

An autoclave is a (large) oven that can be pressurised. As an autoclave is a pressure vessel, it usually has a cylindrical shape (see Figure 25). If a workpiece is closed off and pressurised, excessive resin may be removed, and air inclusions in the material may be reduced, similar to the process in vacuum techniques. Unlike vacuum processes, autoclaves are not restricted to a maximum of 1 bar. In general, pressures can be applied of up to ca. 40 bar. The oven function of an autoclave can be used to complete the correct temperature cycle for optimal curing.



Figure 25: Autoclave at the composites lab, INHolland, Delft

Heating with an autoclave is relatively expensive. Therefore, if high pressure is not required, there is no reason to use an autoclave. The dimensions of the workpiece are

limited to the internal dimensions of the autoclave. Autoclaves are used regularly in the production of aircraft components.

2 - 4 Further machining and material removal

As in all design techniques, composites may require a certain amount of further finishing or machining. In many mould technologies, it is necessary to machine the edges. Sanding and polishing can be desirable. Painting a composite structure can be avoided by mixing pigment with the resin or applying the coat of paint in the mould itself (gelcoat).

The two most important matters to be taken into account when finishing or machining composites are:

- Excessive wear of the tools (e.g. due to the presence of glass fibres in many composites);
- The by-products released during machining, finishing, and material removal. The extent to which dust and fibrous particles may be harmful are not (yet) fully known, but many polymers and particles can be irritating, toxic and/or carcinogenic.

In addition, the same considerations play a role as when machining wood and metals, for example the temperature of tools and products.

If these aspects are taken into consideration, composites can be excellently sanded, sawn, milled and water-jet cut. When designing a composite structure, the question should be raised whether the planned joints, machining and material removal operations are really necessary, and whether they can be avoided by suitable adaptation of the design.

2 - 5 Sources

- [1] Illustration adapted from Pultrex
- [2] Illustration by courtesy of Joop van den Burg, Bijl Profielen
- [3] See www.rijkswaterstaat.nl/rws/e-zine/vezelversterktekunststof/productie.php
- [4] www.Polyworx.nl
- [5] Vereniging Kunststof Composiet Nederland, 'Ontwerpsoftware' (Design software), Fact sheet on designing with composites, part 7, via www.vkcn.nl

2 - 6 Exercises for this chapter

- 1) *Describe at least four processing methods for composites.*
- 2) *What is an autoclave?*
- 3) *Explain the difference between a plug and a mould.*
- 4) *Put these vacuum injection-related terms in the correct order: release agent – mould – peel ply – fibre package – vacuum film – bleeder/breather fabric.*



Calculation methods for determination of structural strength and stiffness are useful tools in every upcoming engineer's toolbox.

Chapter 3

Design of laminates

After completing this chapter, you will be able to describe most of the failure mechanisms of a composite and provide possible remedies. You will be able to make a simple estimate of the stiffness of a laminate. In addition, you will be familiar with multiple-axis failure criteria and understand how classical lamination theory works.

One of the major advantages of composite materials is that you can integrate strength and stiffness into them. You can adapt these characteristics to loads in a particular direction and at a particular place in the material ('tailoring'). This means that structural calculations often differ from those for isotropic materials. This chapter discusses a number of computational methods.

There are many ways in which you can construct composites. However, there are many ways in which they can break. In existing computational methods, many failure mechanisms are difficult to take into account. This means it is very important to be aware of the most important failure modes. Before discussing calculation and design methods, we will focus on the most common failure mechanisms and some courses of remedial action.

3 - 1 Description of a laminate

For manufacturing purposes as well as for structural calculations, it is convenient to have a clear description of a laminate. We do this by first choosing a main direction. This is often the direction of the highest stress in the structure or the laminate. We then determine the angle relative to this main direction for each layer, from bottom to top, as follows:

[angle of layer 1 w.r.t. main direction / angle of layer 2 / angle of layer k.../.../angle of layer n]

Thus, as an example: [0/-45/+45/90] for the laminate in Figure 26. Note that a large quantity of information is missing in this format. For example, it does not specify the fibre/resin combination in each layer. Neither does it specify whether a sheet is a woven fabric or a non-crimp fabric, or what the thickness of the layer is.

Methods are available to simplify the format in some cases. For example, if you wish to describe a unidirectional laminate that consists of 20 layers, you do not need to specify each sheet. Instead you could simply write:

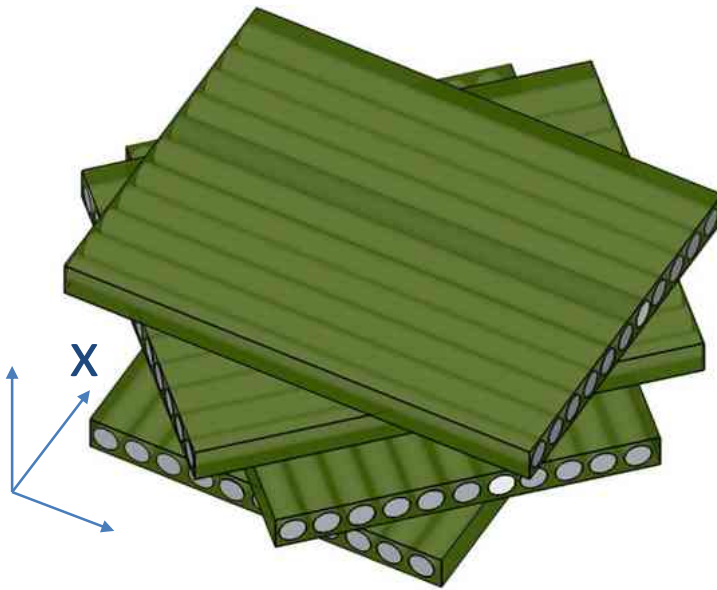

Figure 26: Example of a laminate structure

(x is the main direction; clockwise is positive in this example)

subscripts for thicker symmetrical laminates. In addition, text can be added at the layer locations, e.g. to indicate a 'chopped strand mat' or the type of material. These notational rules are not very strict, because additional text is often necessary when describing a laminate anyway. For example:

$[CSM/90G(400gsm)_2/\pm 45G(400gsm)/0C(600gsm)]_{2s}$

This describes a symmetrical laminate of 20 layers in which a chopped strand mat (CSM) is alternated with two layers of glass (G) at angles of 90° and $\pm 45^\circ$ (the latter layer could be a square woven fabric) and a layer of carbon (C). The surface weights (grams per square meter) are specified. This does not specify precisely what kinds of materials are used in the plies (glass or carbon type, and the resin used) or what the sheet thicknesses are. Additional accompanying text is therefore required.

Note that, next to a symmetrical laminate, laminates can also be 'balanced'. This means that for every layer, there is an identical layer with the opposite fibre orientation. If a laminate is both balanced and symmetrical, there are no coupling effects (see Chapter 3).

3 - 2 Failure mechanisms

Like all materials, composites can fail. An important difference with respect to isotropic materials is that there are a multitude of basic failure mechanisms. These are related to laminate structure and loading. The most important mechanisms are discussed here. Failure mechanisms are classified according to two categories: mechanical and other failure mechanisms.

$[0]_{20}$

For a symmetrical laminate in which the same plies lie at equal distance on both sides of the centre plane (with respect to angle, thickness and materials), you can use the subscript s:

$[0/90]_s$

to indicate a $[0/90/90/0]$ lay-up. You can also combine the

One failure mechanism often leads to the initiation or further development of another failure mechanism. In composite materials, such secondary (or tertiary, quaternary etc.) mechanisms do occur.

3 - 2.1 Mechanical failure mechanisms

3 - 2.1.1 Splitting

If many fibres run in one direction and adhesion in a transversal direction with respect to the fibres is somehow inadequate, a composite can split relatively easily. Splitting causes cracks to occur in the composite. These run parallel to the fibres and throughout the whole thickness dimension of one or more plies. Splitting can be caused by in-plane-bending or by a wedge effect in a bearing or connection. See Chapter 5, for example.

A good remedy is to choose the laminate structure such that plies in which the fibres have been oriented in one direction are alternated with plies with fibres in other directions. Often UD plies are provided with the necessary transversal reinforcement to prevent splitting.

3 - 2.1.2 Delamination

Delamination resembles splitting. In this case, however, the tear is formed between two plies in the plane of the laminate (Figure 27). This form of failure can easily occur, since shear stress between plies can be high and generally no reinforcement between the layers is provided. Although delamination can begin anywhere in a composite, the edges of a sheet or laminate are particularly vulnerable. When two plies have very different stiffness values (or



Figure 27: Delamination (source WMC)

their highest stiffness lies in two different directions, for example), the laminate will be more sensitive to delamination. This is inherently the case with sandwich materials, where there is generally a great difference in stiffness between the core and the skins. If the skin of a sandwich comes loose from the core, this is considered to be delamination.

The resistance to delamination can be determined from an interlaminar shear test. One remedy is preventing high shear stresses between plies. This can be done by reducing the external loads or by providing extra layers. Good finishing of the edges also helps. An effective remedy is avoiding differences in stiffness between plies. Finally, there are reinforcing materials and sandwich structures in which fibres run in the thickness direction as well. Plies can be stitched together during the manufacturing process. Since the thickness direction in a laminate is often indicated by the dimension Z , this is called Z -pinning or Z -stitching.

The use of thermoplastics – which are generally tougher – can increase the resistance to these failure mechanisms with respect to both splitting and delamination.



Figure 28: Buckling of plies and secondary delamination

3 - 2.1.3 Buckling

Macroscopic or Euler buckling is a structural property which can occur in long, slim compression elements, regardless of the material used. The same calculation rules which apply to other materials also apply for composites.

Damage through buckling should be taken into account when working with composite materials. This concerns fibres, fibre bundles and plies that buckle out under the influence of a compressive load (often in this sequence). When plies buckle out, this often results in delamination damage (see Figure 28).

Resistance to macroscopic buckling can be increased by using a more rigid material or structure. Another way to increase resistance is to use a smaller buckling length, e.g. by reducing unsupported lengths or using thicker sandwich layers.

3 - 2.1.4 Fatigue

If alternating loads are repeated frequently enough, they can eventually cause damage. Fatigue occurs in many materials. We know a fair amount about fatigue in steel. This kind of fatigue usually starts at a notch, where a crack is formed. This crack slowly develops further under the influence of varying loads. When it reaches a critical length, the structure fails.

Not as much is known about fatigue in composites. It is clear, however, that the failure mechanism is quite different than in steel.

An important difference is the number of fatigue cracks that can occur simultaneously in a laminate. This is much larger than in a comparable steel structure. Cracks in laminates can start and develop in various directions. They can even join to form larger cracks and delaminations.

The fact that many failure mechanisms occur during fatigue – sometimes even 'collaborating' failure mechanisms – does not mean that composites perform worse. On the contrary, a well-designed laminate is often capable of handling much heavier fatigue loads. This is reflected by the slope of the so-called S-N curve. This curve shows the relationship between a load 'S' and the fatigue life, e.g. the number 'N' of alternating loads until fracture occurs (see Figure 29). The S-N curve for composites is generally 'flatter' than for steel. This means that a reduction of stress results in a longer life cycle. A flat slope of an S-N curve is often regarded as a favourable property. This can be disputed, however, since a flat slope implies that an increased load leads to a relatively shorter life. Despite this, it remains a fact that many composite materials show very high fatigue lives for low-stress loads. Fatigue lives are sometimes so long that end-of-life is not reached during use or testing.

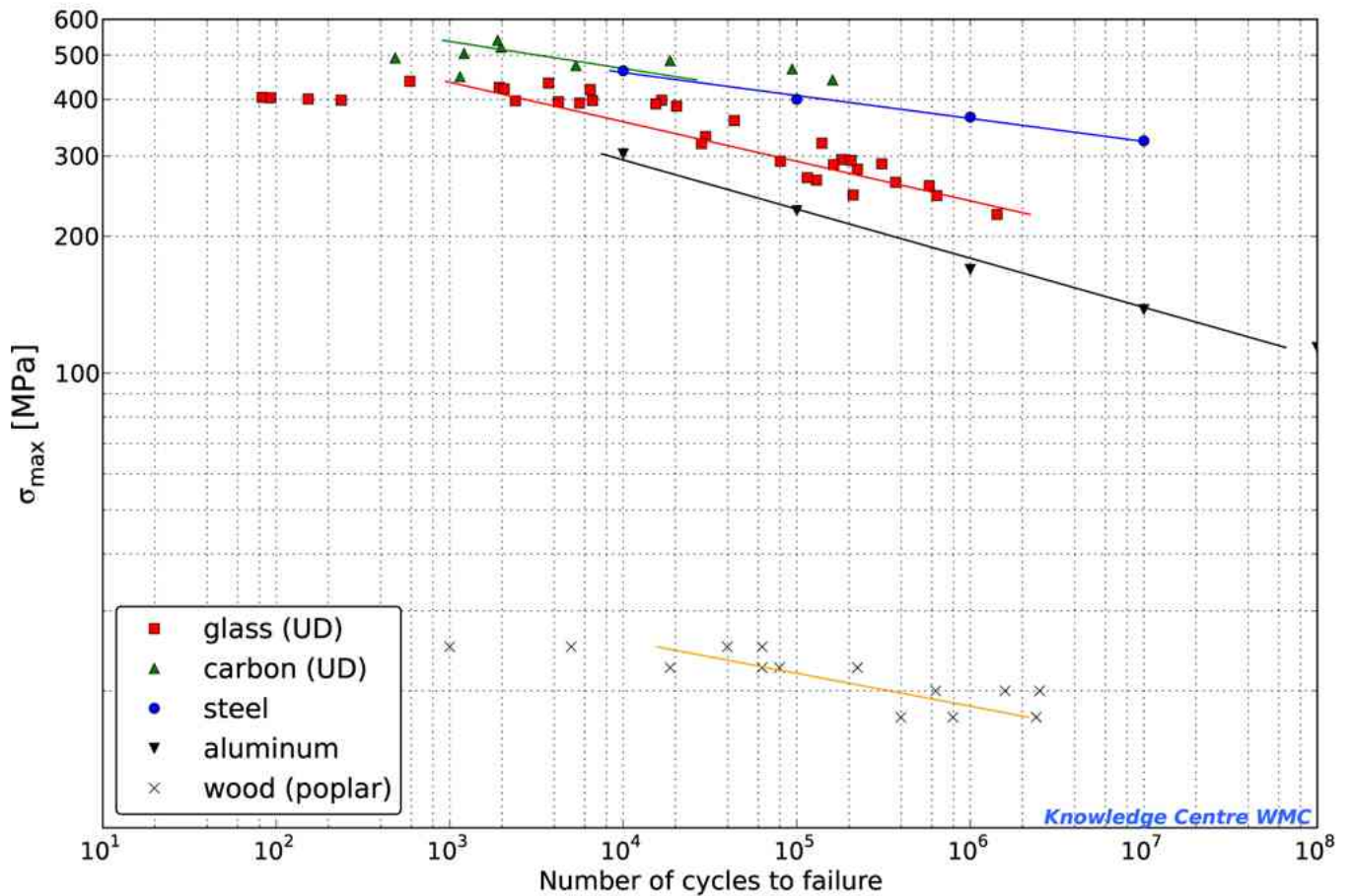

Figure 29: S-N curves for different materials (source: WMC)

The slope of an S-N curve is indicated in the following formula by m . This factor lies in the order of approximately -10. A value of approximately -7 means that a 10% increase or reduction of the stress – e.g. by adding or omitting 1 ply in 10 in the design – leads to a 50% reduction or increase of the life cycle respectively. A slope of -24 increases or reduces the lifecycle by a factor of approximately 10 at the same load change.

$$\log(N) = m \log S + b$$

In this formula, N is the life in number of load cycles, S is the maximum stress that occurs, m is the slope of the curve and B is a parameter that determines the position of the S-N curve.

Another important difference with other materials is that composite materials lose part of their stiffness under the influence of fatigue. This loss of stiffness increases if more fibres lie in other directions than the load. Fatigue loads with an average tensile stress or compression stress can cause creep (in the case of constant loads) or stress relaxation (in the case of external pre-tensioning or constant displacement).

Fatigue damage can be avoided by adapting materials and fibre orientations to the load, by changing the structure in such a way that loading is optimised or by lowering the stress in

the structure by adding more layers. When assessing fatigue sensitivity, joints and structural details in particular should be viewed critically and frequently tested.

3 - 2.1.5 Impact damage

If impact is a possible load case for your design, you should take into account that this kind of damage can be difficult to detect in composites. This is due to their elastic behaviour. The severity of damage is not always obvious from the state of the impacted surface. Although metals often show clear dents, laminates tend to bounce back – even if cracks and delaminations are present deeper in the laminate.

From the design point of view, this means that allowances must be made for the accessibility of both sides of the laminate for inspection, maintenance and possible repair purposes. This means that the scale of impact damage must be taken into account in the functional design stage.

3 - 2.1.6 Creep and stress relaxation

If you suspend a constant load from a metal rod, the rod will first stretch elastically. After that, it does not change shape. Rods made from polymers and certain other materials will keep stretching, however, and eventually they can break. This phenomenon is called creep (rupture). Creep also occurs in the case of compression stresses. As a result, externally imposed pre-stresses can be reduced, leading to decreased material stress levels. This is referred to as stress relaxation.

Glass fibre and most carbon fibres are rarely sensitive to creep. Aramid fibres, on the other hand, are creep-sensitive due to their polymeric nature, like most resins. The effects of creep can be reduced by the correct choice of material and by allowing for this in the design.

In most composites where the fibres carry the load and relieve the stress on the resins, little creep will occur. Examples are UD laminates. You should allow for the effects of creep in laminates and structures where the resin absorbs a large part of the load (e.g. laminates with fibres in the load direction, bonding, out-of-plane loading etc.). Higher temperatures or harmful effects on the material through environmental influences greatly affect creep behaviour. Despite this, some publications describe how creep fracture occurs in UD glass fibre-reinforced polyester and epoxy after approx. 10^5 minutes at 50% and 70% respectively of the quasi-static fracture strength (see [1]). This is attributed to fracture of the weak fibres, after which the load on the other fibres is transferred by means of shear stress in the matrix. This shear stress is subject to redistribution due to creep. This allows a chain reaction of fibre fracture to occur.

3 - 2.2 Other failure mechanisms

3 - 2.2.1 Osmosis

Osmosis is a general term for the transport of water or dissolved substances through a medium as a result of differences in concentration. In composites, this term generally refers to the absorption of water by the resin. This can lead to damage.

When permanently exposed to moisture, most resins will absorb water. This can amount to an increase of several percentages in weight. Water absorption is reversible. If a composite is dried, the water will disappear from the resin. The damage that was caused is not always reversible, however. A resin that is fairly sensitive to damage by

water absorption is polyester. On a molecular scale, water molecules will not only accumulate between the polymer chains, but also disrupt bonding between them. This results in additional space, which is filled up by water again since water molecules attract each other. After a certain period of time, this leads to visible blisters filled with a sourish-smelling liquid (Figure 30). This damage can only be repaired by sanding and polishing, or by applying a new resin layer.

After osmosis or if cracks are present in the resin (e.g. due to fatigue or UV damage), water expanding upon freezing can cause indirect damage.

Damage through exposure to moisture should therefore be avoided. Here too, prevention is better than cure. The use of resins that are only slightly or not at all sensitive to osmosis (vinylester, iso-polyester or epoxy) helps prevent water damage. If this solution is too expensive, it can suffice to apply an outer layer on the composite of one of the resins mentioned. This is often done in the form of a gel coating (an unreinforced, pigmented moisture-resistant resin layer of 1-2 mm thickness, applied in the mould).

Almost all thermoplastics are insensitive to moisture, except for polyamide (nylon).

3 - 2.2.2 UV-damage

Most fibres are not very sensitive to UV damage and are always protected by the surrounding resin. The colour and gloss of the resin can change over time. This is caused by UV radiation, which has a greater effect if a product is not kept clean. The influence of UV radiation on the strength and stiffness properties of a composite is generally limited. This is because any damage is restricted to about the first millimetre of the surface layer.

3 - 2.2.3 Erosion

In applications where an abrasive medium contacts the surface, erosion can occur. At sufficiently high speeds, water has abrasive properties (waterjet cutting is an excellent way to machine composites). Examples of where abrasion can occur are the wheel casings of motor vehicles or the tips of helicopter blades. In first instance, any damage is generally restricted to the surface. Structural properties can be jeopardised, however, if underlying plies are damaged. Testing can provide insight into the sensitivity to erosion. There are many different



Figure 30: Damage through osmosis and hydrolysis: blistering (source: RWS-GPO)

testing methods however. This may make it difficult to compare their results. Applying – thermoplastic – protection strips often offers some protection against erosion.

3 - 2.2.4 Temperature and fire damage

The fire safety of composite materials is an important criterion for the application. Often the material 'competes' with steel, concrete or wood. The development of toxic gases and the loss of strength and stiffness are of great importance in the event of fire. As is the case with other materials, the kind of application largely determines the requirements for fire safety. Relatively little is known about fire behaviour and applicable measures. This chapter discusses the most important aspects.

For almost all materials used for structural purposes, their properties at high temperatures and when burning ultimately lead to structural failure. For wooden structures, this is self-evident. But concrete or steel also become unreliable during fires. In concrete, slaked lime will dehydrate and crumble. Steel structures will deform and/or collapse. A reinforced concrete structure will not catch fire quickly, but once it has suffered a fierce fire it is often no longer suitable for repair.

In many composite materials, the matrix material in particular is sensitive to high temperatures and fire. At temperatures above the glass transition temperature, the matrix becomes rubbery. At higher temperatures, the matrix melts (thermoplastic) and at still higher temperatures the matrix material will burn. This applies to both thermoplastic and thermosetting plastic. This destroys the bonding between the fibres. Particularly in structures in which compression stress prevails, this will quickly lead to failure.

Many measures can be taken to increase fire-resistance and safety. For all structures, the presence of adequate escape routes, smoke alarms and sprinklers, suitable means for smoke removal and fire doors are important. Often a fire-resistant layer is applied. This can be an addition to the existing structural material or a dedicated material.

Another solution can be the application of phenolic resins. These resins perform well up to a temperature of approximately 200°C.

The following further options apply for composite materials:

- **Implementing chlorine or bromine compounds:** chlorine and bromine increase the temperature at which the material burns. The addition of these compounds (referred to as halogenising) increases the flashpoint of a resin. The gases that are released are very toxic, however. Such compounds are generally not very environmentally friendly either.
- **Mixing resin with aluminium trihydrate (ATH):** this aluminium compound (obtainable as a dry, white powder) disintegrates at approximately 180°C. This is an endothermic reaction (and thus withdraws heat from the environment). It produces water as a by-product. This has a fire-retarding effect.
- **Applying thick solid laminates:** an advantage of thick laminates is that the materials have a low thermal conductivity coefficient. This means it will take relatively long before a thick laminate is completely burned. Although the insulation value of a sandwich material can be very high, the core material may be more sensitive to temperature than the skins. In reinforcing materials such as glass,

strength and stiffness limits decrease in the event of fire. Thus in practice, the fire damage for thick laminates will be superficial – the outermost resin layers may incinerate, but with larger structures in particular the reinforcement properties can remain intact for a relatively long period of time. This is particularly the case in designs with non-critical pressure loads. The fibre-metal laminate GLARE turned out to have better fire-safety properties than unreinforced aluminium.

3 - 3 Calculations with composites

Determining the stiffness and strength of your structure is different when you use composite materials rather than isotropic materials. Since layered structures are involved, this applies even if you use quasi-isotropic laminates in your structure.

Various methods have been developed over the years for performing calculations on composites. In general, you begin by determining the stiffness of a ply or laminate.

3 - 3.1 Estimating stiffness and strength

A first step in determining the properties of a ply or laminate is to determine the stiffness. This is done on the basis of the reinforcements and resin used, and on the ratio between the two. For this, the rules of mixture are used. This requires that you specify the fibre content and the fibre and matrix stiffness values. The rules produce the stiffness values in the different main directions. The rules of mixture are based on good adhesion between the fibre and matrix, and on the absence of damage and inclusions.

3 - 3.1.1 Stiffness

3.3.1.1.1 Parallel model

For an estimation of the longitudinal stiffness (i.e. in fibre direction), the parallel model is used (see Figure 31). In this model, a composite is schematised as a 'block' of fibre material next to a block of resin material. The composite stiffness is then calculated as below. The calculation is analogous to electrical parallel switching, for example. In the equations, the symbols E , F , A , v and σ and ϵ (the Greek letters sigma and epsilon) stand for E-modulus, force, surface, volume fraction, stress and strain. Note that a volume fraction in these prismatic cross-sections is equivalent to a surface fraction. The subscripts c, f and m stand for composite, fibre and resin (matrix).

$$F = \sigma_c A_c = \sigma_c (A_f + A_m) = F_f + F_m = \sigma_f A_f + \sigma_m A_m$$

$$\sigma_c = \frac{\sigma_f A_f + \sigma_m A_m}{A_c} = v_f \sigma_f + v_m \sigma_m$$

The strain values for fibres and matrix are equal.

$$\epsilon_f = \frac{\sigma_f}{E_f} = \epsilon_m = \frac{\sigma_m}{E_m} = \epsilon_c = \frac{\sigma_c}{E_c}$$

$$\epsilon_f = \frac{v_f \sigma_f + v_m \sigma_m}{E_c}$$

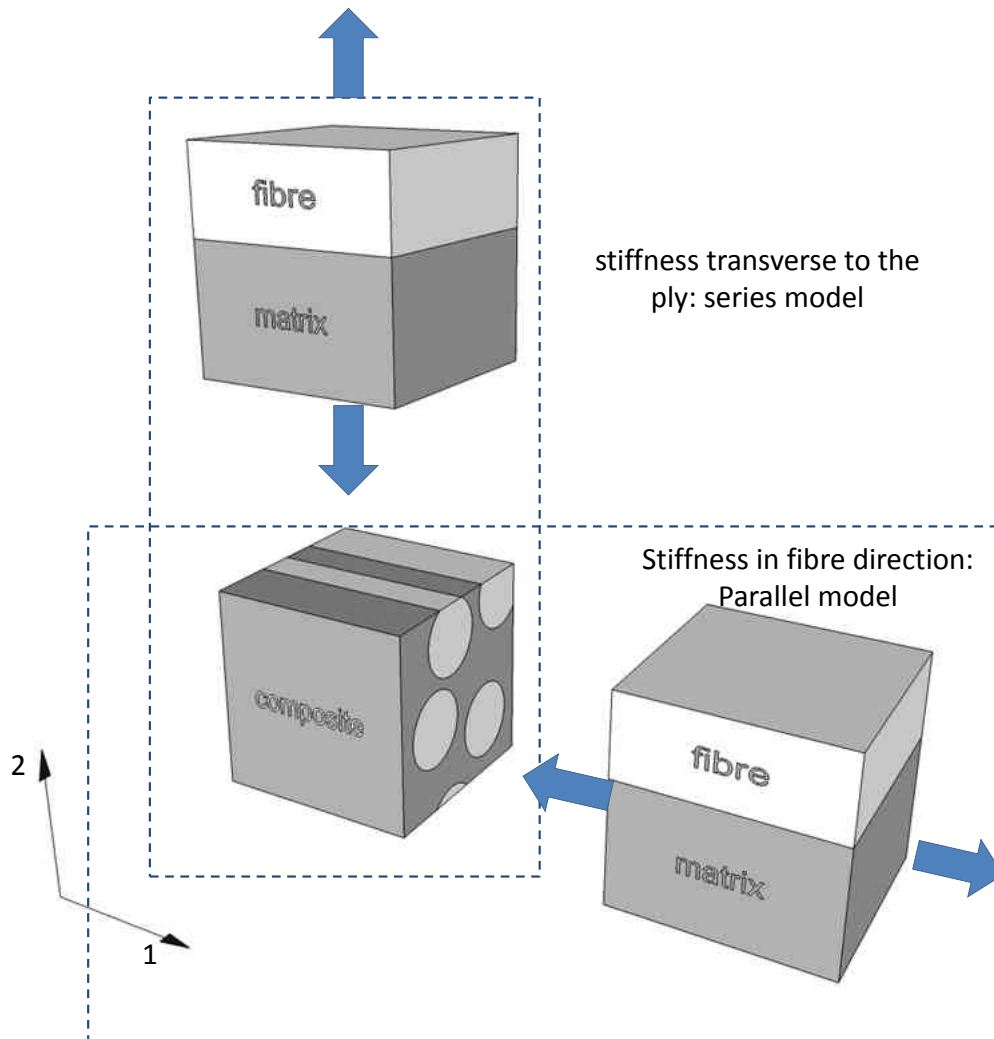

Figure 31: Composite simplified to a series and parallel model

$$E_c = \frac{v_f \sigma_f + v_m \sigma_m}{\varepsilon_c} = \frac{v_f \sigma_f}{\varepsilon_f} + \frac{v_m \sigma_m}{\varepsilon_m} = v_f E_f + v_m E_m$$

3.3.1.1.2 Series model

The simplest model with which the transversal stiffness can be determined is the series model (see Figure 31). In this model there is a situation where the stresses must be equal:

$$\sigma_c = \sigma_m = \sigma_f$$

$$E_c \varepsilon_c = E_m \varepsilon_m = E_f \varepsilon_f$$

$$\sigma_c = E_c (v_m \varepsilon_m + v_f \varepsilon_f)$$

$$\frac{1}{E_c} = \frac{\varepsilon_c}{\sigma_c} = \frac{v_m + v_f}{\sigma_c} = \frac{v_m}{\sigma_m} + \frac{v_f}{\sigma_f}$$

$$\frac{1}{E_c} = \frac{\nu_m}{E_m} + \frac{\nu_f}{E_f}$$

In practice, it is not justified to rely on predicted values such as derived above. The series model in particular is not fully consistent with real-life situations. For this reason, many improved models have been developed, e.g. the Halpin-Tsai method. Experiments often provide a more accurate understanding of the stiffness properties of a specific material.

3 - 3.1.2 Strength

The direction of the fibres would enable you to obtain the strength value, using the fibre strength and the fibre content. In the transversal direction, you must assume that the strength of the resin is dominant for strength calculation purposes. You must take the influence of the fibres into account however.

A complication occurs when a ply is loaded along multiple axes. That can occur when a structure is actually loaded in different directions simultaneously. It can also occur when a particular ply is loaded by the neighbouring plies along several axes or by the structure of the ply itself. In a ply with $\pm 45^\circ$ fibres that is subjected to a tensile load in the 0° direction, for instance, both tensile and shear stress prevail.

For this reason, a so-called multi-axial stress or elongation criterion is often applied when estimating strength under multiple-axis loads. This can be an independent criterion (in which the strength in a main direction is not influenced by the stress in another direction) or an interactive criterion (in which the strength is influenced by stress in another direction). Figure 32 shows an independent ('maximum stress') and a dependent ('Tsai-Hill') failure criterion in three dimensions. The rectangle (light-blue) and the asymmetrical ellipsoid (dark-blue) give an example of such an independent and interactive failure criterion, respectively.

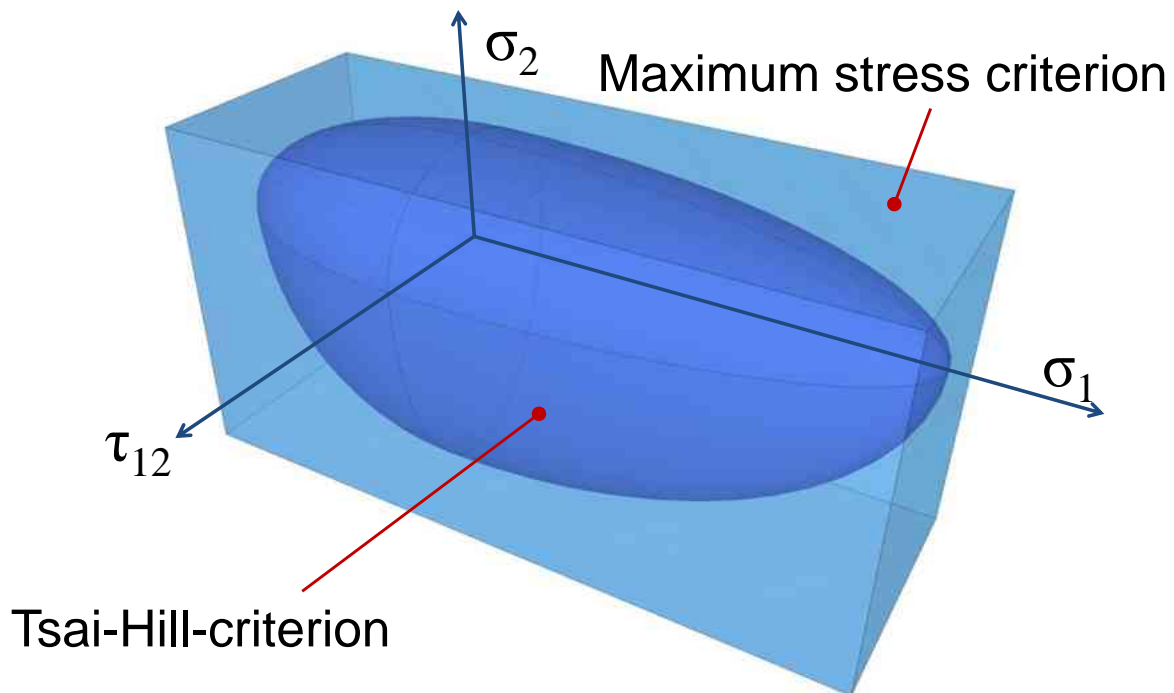

Figure 32: 3D examples of an independent and an interactive failure criterion

The 3D shapes define the 'space' in which a laminate or a ply are still whole. The simplest independent failure criterion determines whether at least one of the stresses is greater than permissible. The value of stress in the other directions is irrelevant. This is shown by the light-blue 'bar', in which the lateral planes represent the maximum tensile stress, compression stress or shear stress. As long as you remain within these planes, the laminate or the ply is intact.

The disadvantage of this criterion is that it predicts that in the longitudinal direction, for example, the single-axis tensile strength can always be obtained. In practice, a simultaneously occurring shear or transversal stress will ensure that the tensile strength is not obtained. The tensile strength in the direction '1' is thus dependent on the stress in direction '2' as well as on the shear stress. An example of a permissible space is shown by the asymmetrical ellipsoid. For a particular stress in the direction of '2', you can no longer obtain the original tensile strength (indicated by the right end). You will arrive at a lower value instead.

Generally a failure criterion is drawn in two dimensions. In that case, you will see the projection of these bodies on the (σ_1, σ_2) - or the (σ_2, τ_{12}) -plane. Since the strengths of a ply or laminate in tensile and pressure direction and in longitudinal, transversal and shear directions are generally unequal, the bar and the ellipsoid are not symmetrical with respect to the origin. You can also formulate these and other criteria in terms of strain. That is often even more convenient when performing calculations on laminates.

Here too the model should be used as an initial estimation. This can then be verified by testing, for example. This may involve the use of prototypes, if possible on a true scale and in a laboratory (but preferably under practical circumstances). You should also take the influence of time, temperature, humidity, radiation, etc. into consideration.

Finally you carefully consider what is meant by 'failure'. In strength analysis, a distinction is made between 'first-ply failure' and 'last-ply failure' (i.e. collapse of the first and last laminate respectively). For the first-ply failure of a laminate, you calculate which ply fails first. This does not necessarily mean that all of the laminate fails immediately. It may even have some remaining strength. In a square laminate for example (with as many plies at an angle of 90° relative to the load direction as at an angle of 0°), the 90° layer can fail first if a particular strain is applied to the laminate. The 0° layers will carry most of the load in such a laminate. That will remain this way if the 90° layers have failed. A 'first-ply failure' analysis predicts the failure of the 90° layers, but the laminate will then not yet have failed.

The complete failure of the laminate can be described by extending the calculation and investigating the sequence in which the layers fail and assessing how much of the load is transferred to the remaining layers after the failure of each layer. The complete failure is referred to as 'last-ply failure'. Such an analysis is less conservative, that is, no strength is left after failure of the layer. For some laminates, the calculation is more complex. For unidirectional laminates, first and last-ply failure are close to each other. For a multiple-axis laminate, first-ply failure can be interesting if danger of leaking is an important consideration, e.g. in pressure vessels.

3 - 3.2 Classical laminate theory

A laminate is built up from different plies, each with its own properties. For laminates with plies that are all equal and lie in the same direction, the laminate properties – the relationship between external load/stress and strain – can be easily derived. But when plies are stacked in different directions, the stiffness in a particular laminate direction will differ per ply. This is because an external load then results in different internal ply stresses. A 'slack' ply will stretch just as much as a 'rigid' one, since the plies are bonded to each other. Due to the difference in elasticity modulus, however, the slack ply will be under less tension (see Figure 33).

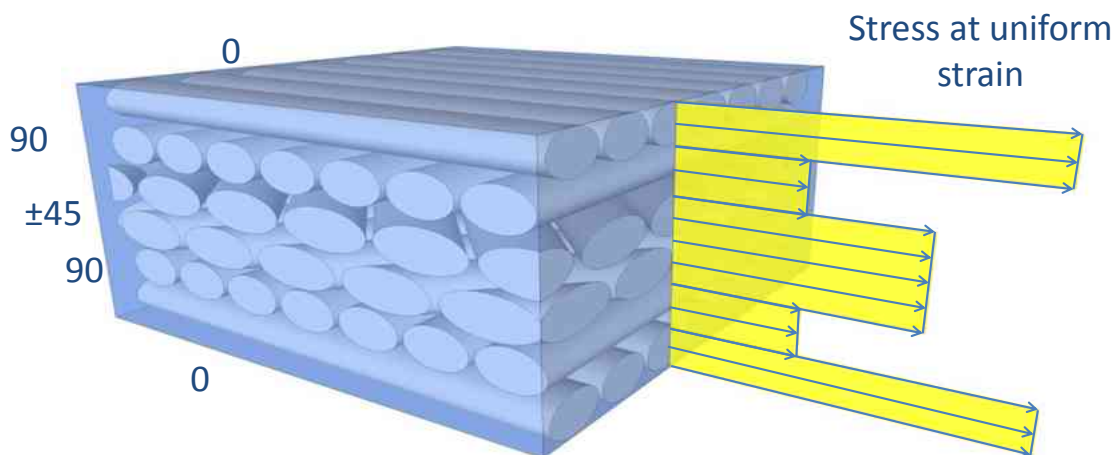

Figure 33: The stress in a ply is dependent on the stiffness of the ply

This has an important consequence: if you want to determine the strength of a laminate, you need to calculate the stresses per ply on the basis of the strain values and test them with a failure criterion. However, the strain of the laminate depends again on the combined stiffness values of the plies!

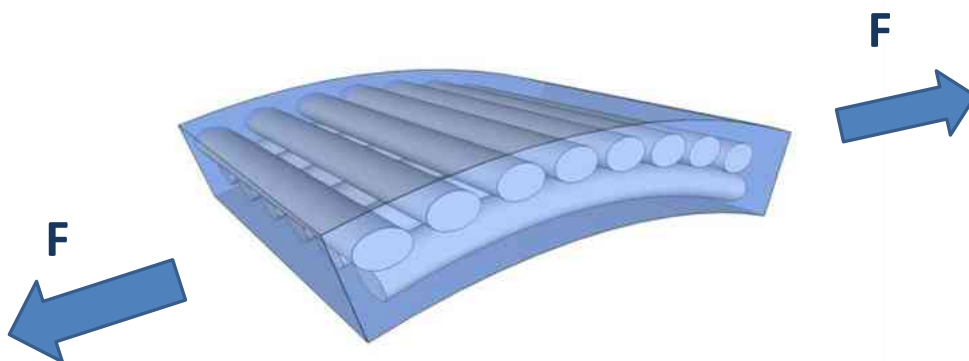

Figure 34: Coupling effects

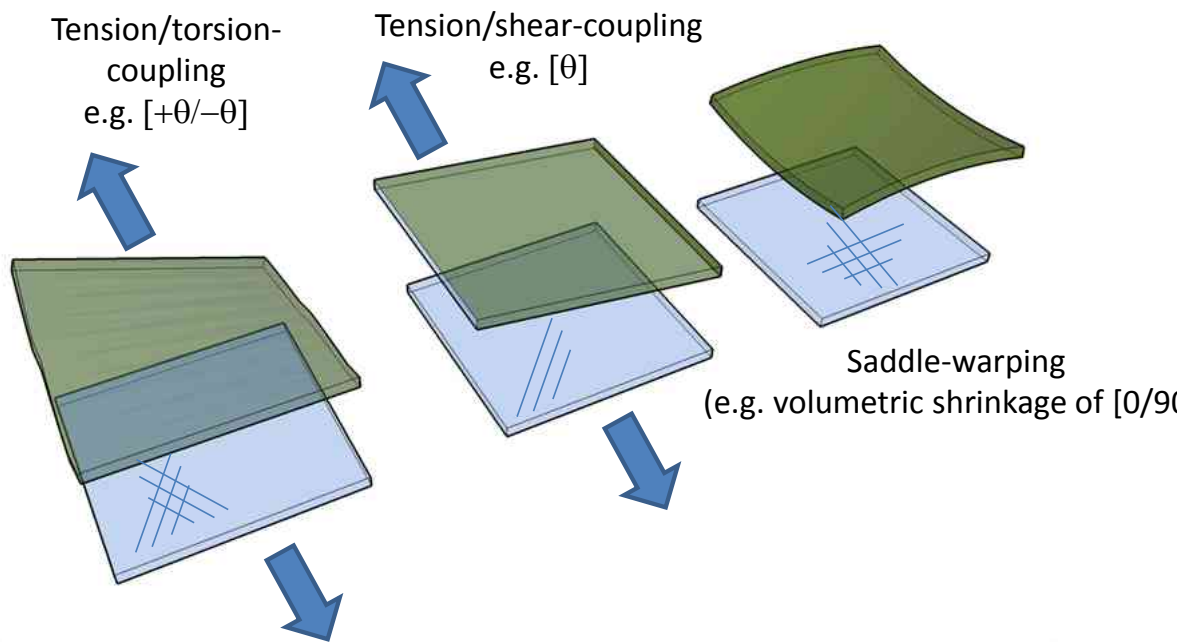

Figure 35: More coupling effects that can occur as a consequence of laminate structure

In addition, coupling effects can occur, e.g. when the ply stiffness values do not lie symmetrically relative to the centre of the laminate (see Figures 34 and 35), or when the laminate is not balanced. In Figure 34, the top layer is provided with fibres transversely to the bottom layer. When a load F is applied, the top layer (which is less rigid in the load direction) will elongate more than the bottom layer. This will cause the laminate to curve. Thus there is a 'coupling' between the load direction and the deformation in other directions.



Figure 36: Aircraft in which a coupling effect has been deliberately 'built-in'

Such coupling effects can be desirable. Experiments have been carried out on aircraft wings, for example, with a built-in relationship between lift and the angle of incidence. In these experiments, use was made of the possibilities of a composite to improve the stability of an inherently unstable wing configuration (see Figure 36).

When designing a laminate, it is important to know its strength and stiffness, and to control possible coupling effects. To this end, a theory known as

'Classical Lamination Theory' (CLT) has been developed. This is very suitable for calculating the stress and elongation of each ply under an external load (force or moment). The application requires fairly extensive calculations however, involving heavy use of linear algebra. For manual calculations, this theory is less suitable. CLT is used particularly in software applications.

3 - 3.2.1 Assumptions

Classical lamination theory is based on the following assumptions. These directly indicate limitations and possibilities:

- **'Smeared properties'**: the structure of the fibres and resin is not modelled. For each ply, 'smeared' properties are used. This means you cannot use the theory to determine what takes place at a microscopic level within a ply. It is also assumed that the fibre content is constant;
- All plies stick to each other: **the theory is not valid for delamination**;
- The theory is **linear elastic**: any non-linear behaviour of the participating plies is not taken into account;
- The laminate has a **constant thickness**: the theory is not valid in the vicinity of ply-drops or other thickness jumps;
- The laminate is **undisturbed**: the theory is not valid in the vicinity of holes, inclusions, inserts, corners and edges;
- The plies are **thin compared to the laminate**.

3 - 3.2.2 Overview of CLT

The flowchart in Figure 37 shows broadly how CLT works.

First of all, the 'technical constants' per ply are determined. These are the values of the

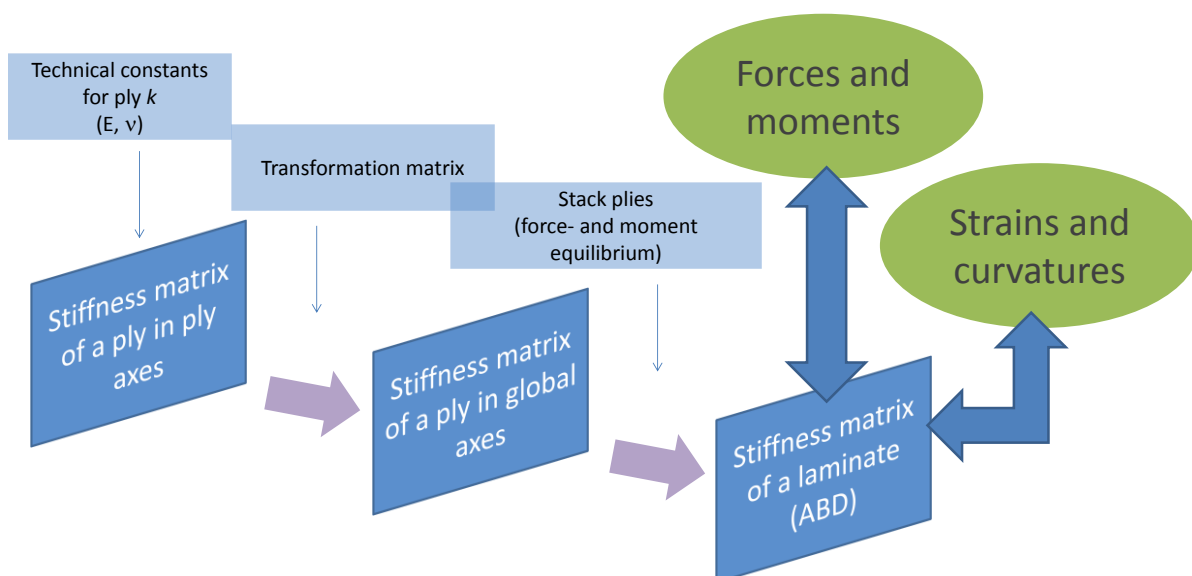

Figure 37: Overview of classical lamination theory

elasticity modulus and the Poisson ratio in each direction of the ply. Then the stiffness matrix and/or the compliance matrix of each ply is determined in the main directions of the ply, e.g. in and perpendicular to the fibre direction. This matrix establishes the connection between stress and strain and contains the technical constants.

Because a ply can be processed in an arbitrary direction in a laminate, the main direction of the ply is not always parallel to the main direction of the laminate. This is often the load direction and the direction perpendicular to it. In a UD ply, the fibres will not always lie in the load direction. Thus the ply is applied in a 'rotated' direction in the laminate plane. The properties of the ply must be determined in the main direction of the laminate. This takes place using the transformation matrix. Since a rotation in the plane of the laminate is always involved in these considerations, you could also refer to this as a rotation matrix.

When the plies are stacked, the stresses can be calculated in each ply as a function of the external load and a combination of the (transformed) ply properties – at least if the

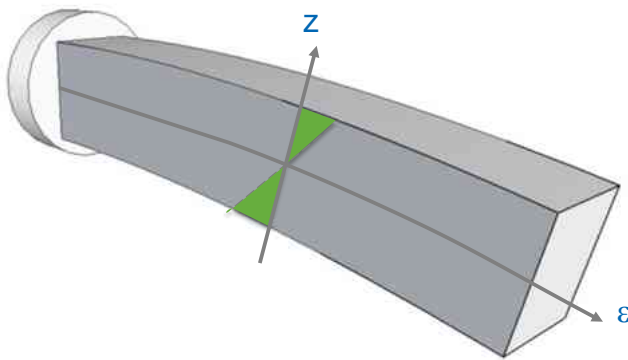

Figure 38: Curvature under the influence of bending; resulting strain pattern

external load is a normal load in parallel to the plane of the laminate. To this end, the stiffness matrix of the laminate is determined from the stiffness matrices of the plies.

In order to calculate the response at a bending moment as well, curvature of the plate must be introduced. This curvature is in fact again translated back to the strain values of the plies: plies that

lie further from the neutral – elastic – line, stretch further than the plies that are near it (see Figure 38). The curvature here is curvature under the influence of load, not curvature that was present beforehand.

The matrix that shows the relationship between external perpendicular and moment loads and the strains and curvatures in the laminate is called an ABD matrix. The 'A' part describes the strains ε in the plane of the laminate as a consequence of in-plane loads N (and vice versa); The 'B' part describes the strains in the plane as a consequence of bending moments M and the curvatures κ as a result of the in-plane loads. The D matrix describes the relationship between curvatures and bending moments. The terms that do not lie on the main diagonal describe the relationships between strains/curvatures and loads that do not lie mutually in the same direction. These are the coupling effects.

$$\begin{Bmatrix} N \\ M \end{Bmatrix} = \begin{bmatrix} A & B \\ B & D \end{bmatrix} \begin{Bmatrix} \varepsilon \\ \kappa \end{Bmatrix}$$

3 - 3.2.3 CLT step by step

The CLT 'components' are discussed below in greater detail.

3.3.2.3.1 Constitutive equation of a ply

The relationship between stress and strain is called a 'constitutive' relationship. For a one-dimensional bar, this is simple and equal to Hooke's law. For an element in a flat panel of an anisotropic material that can be loaded in several directions, the constitutive relationship is somewhat more complicated. The constitutive equation of an orthotropic ply is as follows:

$$\begin{Bmatrix} \varepsilon_1 \\ \varepsilon_2 \\ \gamma_{12} \end{Bmatrix} = \begin{bmatrix} \frac{1}{E_1} & -\frac{\nu_{21}}{E_2} & 0 \\ -\frac{\nu_{21}}{E_1} & \frac{1}{E_2} & 0 \\ 0 & 0 & \frac{1}{G_{12}} \end{bmatrix} \begin{Bmatrix} \sigma_1 \\ \sigma_2 \\ \tau_{12} \end{Bmatrix}$$

Here the compliance matrix has been written out. You can write this in a similar form, specifying stress as a function of the strain:

$$\begin{Bmatrix} \sigma_1 \\ \sigma_2 \\ \tau_{12} \end{Bmatrix} = \begin{bmatrix} \frac{1}{1-\nu_{12}\nu_{21}}E_1 & \frac{\nu_{12}}{1-\nu_{12}\nu_{21}}E_2 & 0 \\ \frac{\nu_{12}}{1-\nu_{12}\nu_{21}}E_2 & \frac{1}{1-\nu_{12}\nu_{21}}E_2 & 0 \\ 0 & 0 & G_{12} \end{bmatrix} \begin{Bmatrix} \varepsilon_1 \\ \varepsilon_2 \\ \gamma_{12} \end{Bmatrix}$$

To do this, you must invert the compliance matrix to the stiffness matrix.

3.3.2.3.2 Positioning of ply in laminate – the transformation matrix

There are two variants of the transformation matrix: one for stress and the other for strains. The formulation you should use depends on whether the constitutive equations of a ply have been written in terms of a stiffness matrix or a compliance matrix.

$$\begin{Bmatrix} \sigma_1 \\ \sigma_2 \\ \tau_{12} \end{Bmatrix} = \begin{bmatrix} \cos^2\theta & \sin^2\theta & 2\sin\theta\cos\theta \\ \sin^2\theta & \cos^2\theta & -2\sin\theta\cos\theta \\ -\sin\theta\cos\theta & \sin\theta\cos\theta & \cos^2\theta - \sin^2\theta \end{bmatrix} \begin{Bmatrix} \sigma_x \\ \sigma_y \\ \tau_{xy} \end{Bmatrix}$$

for stresses or, simplified:

$$\begin{Bmatrix} \sigma_1 \\ \sigma_2 \\ \tau_{12} \end{Bmatrix} = \begin{bmatrix} c^2 & s^2 & 2sc \\ s^2 & c^2 & -2sc \\ -sc & sc & c^2 - s^2 \end{bmatrix} \begin{Bmatrix} \sigma_x \\ \sigma_y \\ \tau_{xy} \end{Bmatrix} = [T]_{\sigma} \begin{Bmatrix} \sigma_x \\ \sigma_y \\ \tau_{xy} \end{Bmatrix}$$

You can use this equation to calculate the stresses in the main direction of the ply as a function of the rotation in the plane of the laminate of an angle θ . For strains:

$$\begin{Bmatrix} \varepsilon_1 \\ \varepsilon_2 \\ \frac{1}{2}\gamma_{12} \end{Bmatrix} = \begin{bmatrix} c^2 & s^2 & 2sc \\ s^2 & c^2 & -2sc \\ -sc & sc & c^2 - s^2 \end{bmatrix} \begin{Bmatrix} \varepsilon_x \\ \varepsilon_y \\ \frac{1}{2}\gamma_{xy} \end{Bmatrix} \rightarrow$$

Linear algebra

In linear algebra, a set of equations is written in an abbreviated manner. This notation and the associated operations facilitate solution using a computer. Solving a set of equations by hand can be quite labour-intensive. Sets of equations are encountered in various disciplines: biology (e.g. predator-prey systems), when making a railway schedule, in finite elements and...in classical laminate theory.

A set of equations is written using matrices (with n rows and m columns) and vectors (x rows and 1 column). Suppose we apply a strain to a flat panel in two directions (1 and 2). For an isotropic material under plane stress (component in thickness-direction are not considered) the following relation between strain and stress applies in direction '1':

$$\varepsilon_1 = \frac{1}{E}\sigma_1 - \frac{\nu}{E}\sigma_2$$

Since this is an isotropic material, the relation between stress and strain is equal in direction 2:

$$\varepsilon_2 = \frac{1}{E}\sigma_2 - \frac{\nu}{E}\sigma_1$$

In addition, in a flat panel, there is a relation between in-plane shear stress and strain.

$$\gamma = \frac{\tau}{G}$$

We now have three stresses and strains, in three different 'directions'. In an elaborate fashion we could write:

$$\varepsilon_1 = \frac{1}{E}\sigma_1 - \frac{\nu}{E}\sigma_2 + 0\tau$$

$$\varepsilon_2 = -\frac{\nu}{E}\sigma_1 + \frac{1}{E}\sigma_2 + 0\tau$$

$$\gamma = 0\sigma_1 + 0\sigma_2 + \frac{\tau}{G}$$

...but we could also write this in the form of vectors (between curly brackets) and a coefficient matrix (straight brackets)...:

$$\begin{Bmatrix} \varepsilon_1 \\ \varepsilon_2 \\ \gamma \end{Bmatrix} = \begin{bmatrix} \frac{1}{E} & \frac{-\nu}{E} & 0 \\ \frac{-\nu}{E} & \frac{1}{E} & 0 \\ 0 & 0 & \frac{1}{G} \end{bmatrix} \begin{Bmatrix} \sigma_1 \\ \sigma_2 \\ \tau \end{Bmatrix}$$

Linear algebra (continued)

...or shorter:

$$\{\varepsilon\} = [C]\{\sigma\}$$

In the above equation, $\{\sigma\}$ and $\{\varepsilon\}$ are the stress and strain vectors, and $[C]$ is the matrix containing the compliances (or 'flexibilities'; the opposite of stiffnesses or rigidities).

Furthermore, every element of the strain vector is constructed from the three elements of the stress vector (a linear combination), with the coefficients, some of which are equal to 0, listed in the stiffness matrix.

Initially we agreed that we would only consider plane stress. This includes shear stress. Often, a subscript '12' is included in the shear stress and shear strain.

The original set of equations now reads as an algebraic equation; in fact, the equation looks like the inverse of Hooke's law – strain is compliance times stress.

In case you are wondering if this can be written as Hooke's law itself, the answer is yes. In matrix notation:

$$\{\sigma\} = [E]\{\varepsilon\}$$

Here, E (stiffness matrix) is not simply $1/C$, nor is it a matrix consisting of elements which are the inverse of the elements of C , but it is a new matrix: the inverse of C . NB In literature, the stiffness matrix is often designated as Q .

$$\begin{Bmatrix} \varepsilon_1 \\ \varepsilon_2 \\ \gamma_{12} \end{Bmatrix} = \begin{bmatrix} c^2 & s^2 & sc \\ s^2 & c^2 & -sc \\ -2sc & 2sc & c^2 - s^2 \end{bmatrix} \begin{Bmatrix} \varepsilon_x \\ \varepsilon_y \\ \gamma_{xy} \end{Bmatrix} = [T]_{\varepsilon} \begin{Bmatrix} \varepsilon_x \\ \varepsilon_y \\ \gamma_{xy} \end{Bmatrix}$$

Using the preceding formulas, you can now provide the relationship between stresses and strains for a single ply – at an arbitrary angle relative to the laminate stress directions (in the global laminate axis system) – by starting with the constitutive equation for a ply:

$$\begin{Bmatrix} \sigma_1 \\ \sigma_2 \\ \tau_{12} \end{Bmatrix} = [E] \begin{Bmatrix} \varepsilon_1 \\ \varepsilon_2 \\ \gamma_{12} \end{Bmatrix}$$

and 'rotating' this by means of the transformation matrices to obtain the constitutive equation of that same ply in a global axis system:

$$\begin{Bmatrix} \sigma_x \\ \sigma_y \\ \tau_{xy} \end{Bmatrix} = [T]_{\sigma}^{-1} [E] [T]_{\varepsilon} \begin{Bmatrix} \varepsilon_x \\ \varepsilon_y \\ \gamma_{xy} \end{Bmatrix} = [\bar{E}] \begin{Bmatrix} \varepsilon_x \\ \varepsilon_y \\ \gamma_{xy} \end{Bmatrix}$$

3.3.2.3.3 Stacking plies – introduction to curvature

The relationship between the strains and stresses in a ply is thus known in an arbitrary axis system (x, y). When a number of plies is stacked to form a laminate, the external forces in the plane will have to be in equilibrium with the total ply forces. The elongations in a ply are jointly determined by the curvature of the laminate. For equilibrium between internal and external forces, the following then applies:

$$[N] = A\{\varepsilon\} + B\{\kappa\}$$

Here N represents the external load (line load), A represents the ply stress (line stress) as a result of the elongations in the plane and B represents the contribution of the curvature of the laminate (κ).

A similar relationship as above can be written for the equilibrium between external moments and internal strains:

$$[M] = B\{\varepsilon\} + D\{\kappa\}$$

3.3.2.3.4 The ABD matrix

Combination provides the simplified ABD matrix:

$$\begin{Bmatrix} N \\ M \end{Bmatrix} = \begin{bmatrix} A & B \\ B & D \end{bmatrix} \begin{Bmatrix} \varepsilon \\ \kappa \end{Bmatrix}$$

of in extended form:

$$\begin{Bmatrix} n_x \\ n_x \\ n_{xy} \\ m_x \\ m_y \\ m_{xy} \end{Bmatrix} = \begin{bmatrix} A_{11} & A_{12} & A_{13} & B_{11} & B_{12} & B_{13} \\ A_{21} & A_{22} & A_{23} & B_{21} & B_{22} & B_{23} \\ A_{31} & A_{32} & A_{33} & B_{31} & B_{32} & B_{33} \\ B_{11} & B_{12} & B_{13} & D_{11} & D_{12} & D_{13} \\ B_{21} & B_{22} & B_{23} & D_{21} & D_{22} & D_{23} \\ B_{31} & B_{32} & B_{33} & D_{31} & D_{32} & D_{33} \end{bmatrix} \begin{Bmatrix} \varepsilon_x \\ \varepsilon_x \\ \gamma_{xy} \\ \kappa_x \\ \kappa_y \\ \kappa_{xy} \end{Bmatrix}$$

3 - 3.3 Finite Element Method

In the finite element method, a structure is considered as being divided into a large number of 'building blocks', and each block has the properties of the structure material. By using such blocks, the stresses and deformations in a relatively complex structure can be determined on the basis of a simple set of material properties.

For analysing composite structures, FEM can be used. In this case, the possibilities are rather limited compared to the modelling of structures of isotropic materials. Also, the models are often more complex. On the other hand, FEM provides the opportunity to apply relatively simple non-linear material behaviour in a structure. With some manipulation, damage progression in composite structures can be estimated. Possibilities for this are limited to quasi-static failure behaviour in particular, not to fatigue.

3 - 3.4 Rules of thumb for laminate design

In the previous section, the most important failure mechanisms and computational methods were discussed. A good understanding of these mechanisms and methods is of great importance in designing good laminates. Classical lamination theory is suitable for the detailed design aspects of stiffness and the direct integration and calculation of coupling effects. This is also useful as the basis for the analysis of failure of composites, since you can use it to check the elongations and stresses for each ply with respect to the permitted values. Classical lamination theory underpins fine element methods for composites (to quantify the properties of the elements). These finite element methods can in turn be used to perform calculations on design details in particular, such as holes, ply-drops, thickness jumps, and damage (in other words, where classical lamination theory and other theories do not apply).

As has become clear, the application of laminate theory goes hand in hand with linear algebra. It is not always necessary to perform extensive matrix computations, however. Many software applications are available that can help you to apply classical lamination theory and related theories. In many applications, however, you do not always need these for detailed laminate design.

There are simple rules of thumb for designing good laminate structures [2][3]. Some of these are:

- Work with symmetrical laminates.
 - For each layer above the laminate's mid-plane, there is an equal layer below the mid-plane (in terms of distance to mid-plane, thickness, and material)
 - When you use these, the coupling terms in the B matrix become 0.
 - Bear this in mind when laminates are bonded to each other to form a thicker laminate.
- Work with balanced laminates.
 - In this case, for each ply at an angle x there is an equal ply at an angle $-x$. The distance to the mid-plane does not have to be equal.
 - A laminate can be both symmetrical and balanced!
- Prevent stiffness jumps between plies.
 - One way to prevent stiffness jumps is by limiting the mutual fibre angles, e.g. to a difference of 60° .
 - Avoid unnecessary ply drops (internal or surface ply terminations).
 - When bonding two laminates, make sure that the adhesive layer is applied to plies that deviate at most 45° from the main direction.

-
- Use quasi-isotropic laminates where possible.
 - A quasi-isotropic structure results in the least 'surprises'...
 - ... but is often relatively heavy.
 - Avoid abrupt thickness jumps...
 - ... by ensuring ply drops occur one by one;
 - ...by ensuring these ply drops don't occur too close to each other;
 - ... by covering ply ends with a ply.

Note furthermore that a number of these rules of thumb follow from, and can be understood through the use of laminate theory.

Finally, coupling effects due to unsymmetric or unbalanced laminate design will often already show up shortly after manufacturing: the product may come out of the mould warped, curved or twisted due to thermal strains after cooling. In addition, for symmetrical and balanced laminates there may be internal stresses due to differential strains from ply to ply. These may result in unwanted deformations if layers are subsequently sanded away, e.g. during post-processing steps.

You will find more information on the use of composites in construction in [4]. Detailed computational methods are given in [5], for example.

Inverting a matrix

In software like Excel or Matlab, there are dedicated functions to calculate the inverse of a matrix. One way of manually calculating the inverse is 'Gauss elimination'. This method knows a few operations:

- rows can be added to each other
- rows can be multiplied with a number
- rows can be interchanged

We start with the original matrix, augmented with a matrix of the same size, filled with zeros and ones on the main diagonal (the unit matrix):

$$\left[\begin{array}{ccc|ccc} \frac{1}{E} & \frac{-\nu}{E} & 0 & 1 & 0 & 0 \\ \frac{-\nu}{E} & \frac{1}{E} & 0 & 0 & 1 & 0 \\ 0 & 0 & \frac{1}{G} & 0 & 0 & 1 \end{array} \right]$$

Using the above operations, the objective now is to convert the left matrix into a unit matrix; the right matrix will then turn into the inverse matrix. In this case, first multiply the last row with G:

$$\left[\begin{array}{ccc|ccc} \frac{1}{E} & \frac{-\nu}{E} & 0 & 1 & 0 & 0 \\ \frac{-\nu}{E} & \frac{1}{E} & 0 & 0 & 1 & 0 \\ 0 & 0 & 1 & 0 & 0 & G \end{array} \right]$$

Then, multiply the first two rows by E:

$$\left[\begin{array}{ccc|ccc} 1 & -\nu & 0 & E & 0 & 0 \\ -\nu & 1 & 0 & 0 & E & 0 \\ 0 & 0 & 1 & 0 & 0 & G \end{array} \right]$$

Subsequently, add the second row to the first:

$$\left[\begin{array}{ccc|ccc} 1-\nu & 1-\nu & 0 & E & E & 0 \\ -\nu & 1 & 0 & 0 & E & 0 \\ 0 & 0 & 1 & 0 & 0 & G \end{array} \right]$$

Next, divide the first row by $1-\nu$, and the second row by -1 :

$$\left[\begin{array}{ccc|ccc} 1 & 1 & 0 & \frac{E}{1-\nu} & \frac{E}{1-\nu} & 0 \\ \nu & -1 & 0 & 0 & -E & 0 \\ 0 & 0 & 1 & 0 & 0 & G \end{array} \right]$$

Inverting a matrix (continued)

Following this, add the first row to the second:

$$\left[\begin{array}{ccc|cc} 1 & 1 & 0 & \frac{E}{1-\nu} & \frac{E}{1-\nu} & 0 \\ 1+\nu & 0 & 0 & \frac{E}{1-\nu} & \frac{\nu E}{1-\nu} & 0 \\ 0 & 0 & 1 & 0 & 0 & G \end{array} \right]$$

Next, divide row 2 by (1+ν):

$$\left[\begin{array}{ccc|cc} 1 & 1 & 0 & \frac{E}{1-\nu} & \frac{E}{1-\nu} & 0 \\ 1 & 0 & 0 & \frac{E}{1-\nu} & \frac{\nu E}{1-\nu} & 0 \\ 0 & 0 & 1 & 0 & 0 & G \end{array} \right]$$

Then, subtract row 2 from row 1:

$$\left[\begin{array}{ccc|cc} 0 & 1 & 0 & \frac{E}{1-\nu} - \frac{E}{1-\nu^2} & \frac{E}{1-\nu} - \frac{\nu E}{1-\nu^2} & 0 \\ 1 & 0 & 0 & \frac{E}{1-\nu^2} & \frac{\nu E}{1-\nu^2} & 0 \\ 0 & 0 & 1 & 0 & 0 & G \end{array} \right]$$

Finally, rewriting this and exchanging row 1 and 2:

$$\left[\begin{array}{ccc|cc} 1 & 0 & 0 & \frac{E}{1-\nu^2} & \frac{\nu E}{1-\nu^2} & 0 \\ 0 & 1 & 0 & \frac{\nu E}{1-\nu^2} & \frac{E}{1-\nu^2} & 0 \\ 0 & 0 & 1 & 0 & 0 & G \end{array} \right]$$

Now, on the left is the unit matrix, on the right is the inverse of the compliance matrix, this is the stiffness matrix:

$$[C] = [E]^{-1}$$

3 - 4 Sources

- [1] Bryan Harris, Engineering composites, 1999
- [2] van Nimwegen, J et al., 'Bijlage 1 van het eindverslag van de deelwerkzaamheden van het composietenlab Inholland binnen RAAK Composites in Mechatronics' (Appendix 1 of the final report of activities at the Inholland Composites Laboratory within RAAK Composites in Mechatronics), September 2011
- [3] Bastings, B., 'Lichtgewicht construeren – ontwerpen met koolstofvezel composieten' (Lightweight construction – designing with carbon fibre composites), Fontys Hogeschool Engineering, 12 Mei 2012
- [4] Vereniging Kunststof Composiet Nederland, 'Construeren in composieten', 'Ontwerp- en rekenmethodieken voor Composieten', en 'klassieke laminatentheorie' ('Constructing in composites', Design and calculation methods for composites, and Classical lamination Theory'), Factsheets on designing with composites, part 2 to 4 inclusive, via www.vkcn.nl
- [5] Nijhoff, A.H.J., 'Vezelversterkte kunststoffen – mechanica en ontwerp' (Fibre reinforced plastics – mechanics and design), VSSD 2004-2005, ISBN: 90-407-2484-9

3 - 5 Exercises for this chapter

1. Name three failure mechanisms that can occur with composites, including their possible cause and the measures you can take against the occurrence of these mechanisms.
2. Derive the compliance matrix from the stiffness matrix and/or vice versa by inverting the matrix.
3. What is meant by the finite element method?
4. Name at least 4 handy rules of thumb for a good laminate structure.
5. For 55% (volume), a UD ply consists of fibres; the rest is resin. The stiffness of the resin (epoxy) is 4GPa. The stiffness of the fibres (glass) is 72GPa. What is the stiffness in the fibre direction of the ply?



Studying on an empty stomach is not comfortable...time for a sandwich! The invention of spreads and sandwich fillings has significantly expanded the potential of bread. Sandwich materials in turn constitute a great enrichment of the construction material toolbox.

Chapter 4

Sandwich

This chapter aims to teach you how you can determine the strength and deflection of a sandwich composite beam element, including shear deformation. You will become familiar with the most characteristic failure mechanisms.

A sandwich 'material' is a structure that consists of an upper and a lower layer of relatively stiff and strong material. These upper and lower layers are separated from each other at a fixed distance by an intermediate layer. This intermediate layer is generally less strong and rigid, and in all cases very light. Air would be a suitable material for the intermediate layer. Air cannot be bonded to anything however, and its shear stiffness and strength are very low. Foam (which can be regarded as 'air with a skin') is often used as a second best option. Balsa wood is also widely used. In aviation technology, many applications use a honeycomb structure as core material. Below, we will assume the 'skin' to be a laminate. In principle however, any combination of a skin and a core can be included in the definition of a 'sandwich'. A final consideration is the connection between the skin and the core. This connection ensures that the skins and the core can interact (see Figure 39).

A sandwich structure is in many cases analogous to the commonly used 'I-beam' (or H-profile). In these cases, the flanges make the largest contribution to the moment of inertia and thereby absorb most normal stresses. The web plate absorbs shear stresses.

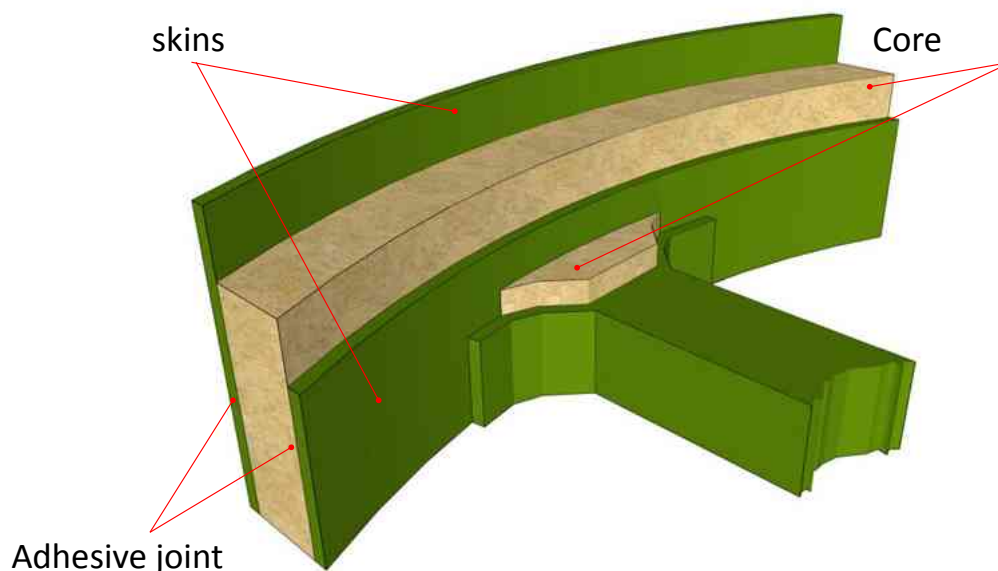

Figure 39: Overview of a sandwich structure

In general, the functions of skin and core material are as follows:

- Skins
 - the skins provide the stiffness and strength in the plane of the laminate and include the most important normal stresses
 - the skins absorb contact forces and serve as a fixing element
- Core
 - keeps the skins at a distance, so that they can fulfil their structural function well
 - dissipates most shear stresses caused by transverse forces
 - supports the skins against buckling
 - takes care of acoustic and, for example, thermal insulation

4 - 1 Bending of sandwiches

Thanks to its structure, a sandwich panel is relatively light for a given stiffness and strength. This makes it suitable for spans (in floors, bridges) and as an anti-buckling panel (in walls, bridges, wings). The impact properties of a sandwich panel can be good, since much energy dissipation can occur in the deformation and failure of the core. On the other hand, implementing joints in sandwich panels is not easy. Inserts are commonly used to this end (see 5 - 2.3). The production of curved sandwich panels is not easy. In addition to flat core panels, grooved core materials are also used. These can bend more easily (see Figure 40).

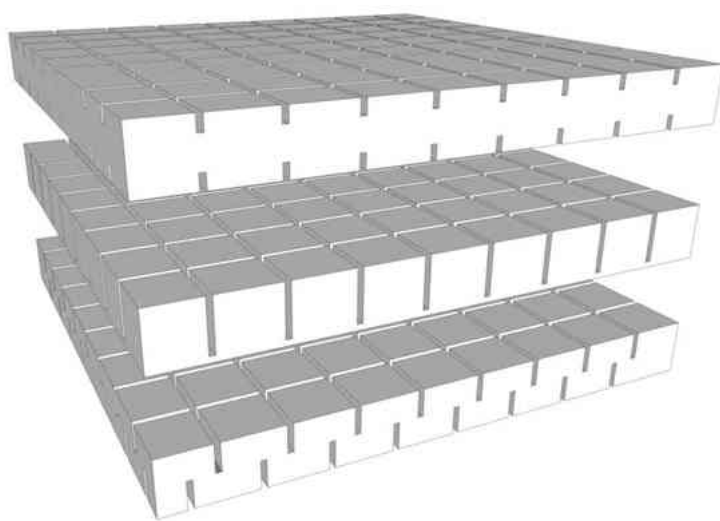

Figure 40: Core materials with grooves or blocks of core material bonded on thin mats are suitable for (double-)curved sandwich panels

When calculating the stresses in a sandwich structure, the theory associated with an assembled beam is often used. For this purpose, the bending rigidity D of the whole bar must be determined. This is equal to the sum of the stiffnesses multiplied by the moment of inertia relative to the elastic axis of the sandwich (see also Figure 41).

$$D = E_f \frac{bt^3}{6} + E_f \frac{btd^2}{2} + E_c \frac{bc^3}{12}$$

where f stands for 'face' and c stands for 'core'. Note that in many cases the contribution of the core (last term) and the contribution of the moment of inertia about the own neutral axis of the skins (first term), can be disregarded [1].

Next, the normal stresses can be calculated. These are generally higher in the more rigid skins than in the weaker cores:

$$\sigma_f = \frac{Mz}{D} E_f$$

$$\sigma_c = \frac{Mz}{D} E_c$$

Here, the letter M stands for the bending moment on the bar and z is the co-ordinate in thickness direction with respect to the elastic axis.

A disadvantage of sandwich panels is that, when relatively shear-flexible core materials are used, the deflection is larger than can be expected on the basis of beam theory. For the total deflection, both the deflection as a result of the normal stress and the deflection as a

result of the shear stress must be taken into account (Figure 42). If shear deformation is not taken into consideration, you are likely to calculate too small a deflection relative to reality. That would result in non-conservative designs (and thus be hazardous).

The associated formula for the shear stress is:

$$\tau = \frac{Q}{bD} \Sigma(SE) = \frac{Q}{D} \left(E_f \frac{td}{2} + E_c \frac{1}{2} \left(\frac{c}{2} - z \right) \left(\frac{c}{2} + z \right) \right)$$

where Q is the tranverse force and S is the resistance moment. Since the contribution of the core to the shear stress is often negligibly small and the difference between the shear stress at the place of the bond with the laminate and at the place of the elastic axis is not so large, the maximum shear stress in the core can be simplified to [1]:

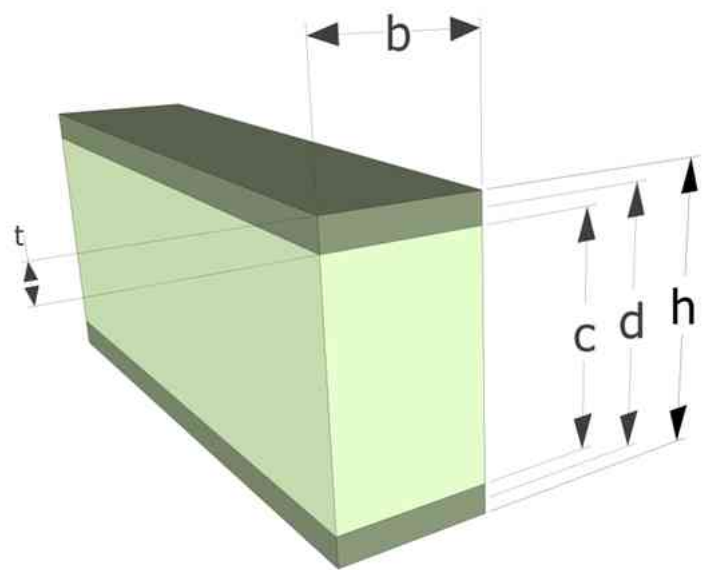

Figure 41: Cross-section of a sandwich of width b , skin thickness t and total thickness h

$$\tau = \frac{Q}{bd}$$

The deflection as a result of shearing follows from the local shear elongations. For a constant transverse force in a bar, this shear angle is also constant. The extra deflection is thus dependent on this angle, multiplied by, for example, the distance to the bearing or clamping point.

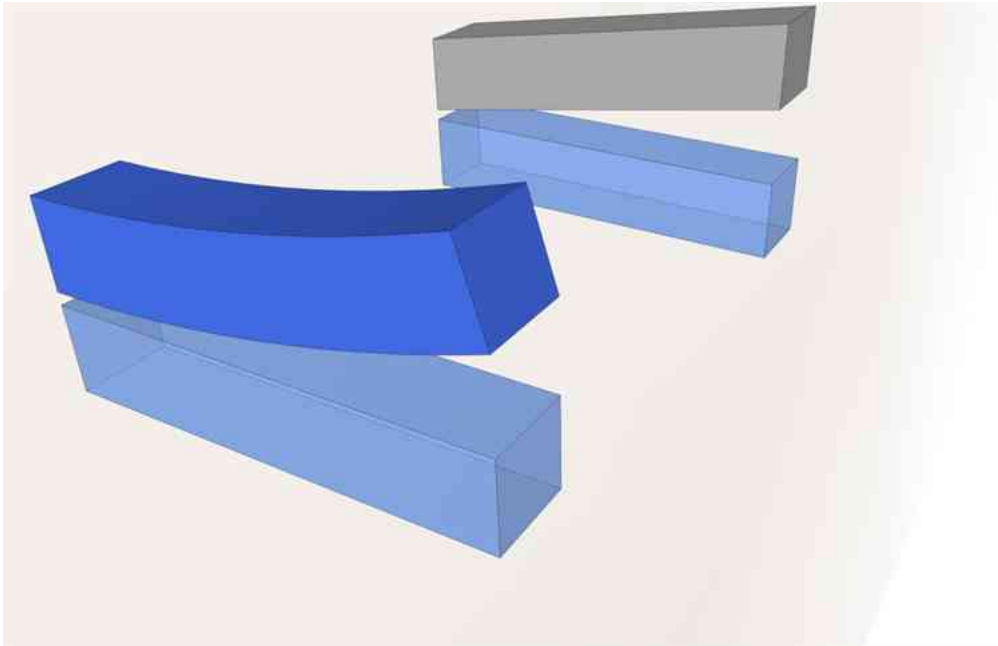

Figure 42: Normal deformation (foreground) and shear deformation in a beam

You should therefore always take both the normal and the shear deformation into account when calculating the total deflection of a sandwich. The formula for the deflection of, for example, a two-sided supported beam with load P in the middle thus consists of two parts:

$$\delta = \frac{PL^3}{48D} + \frac{PL}{4AG}$$

where A is the surface of the cross section of the sandwich and G is the shear modulus (shear stiffness) of the core. If this is low (and that applies for many foam cores), the shearing of the core will significantly contribute to the total deflection.

4 - 2 Buckling of sandwiches

As stated, sandwich panels are very suitable as structural elements that can absorb compressive loads in the plane. The calculation of the buckling resistance is not considered here, but depends on the constraints (the manner of clamping), the stiffness values of the skins and core, and the resistance against bending. The relevant calculations are described in detail in, for example, [1] and [2].

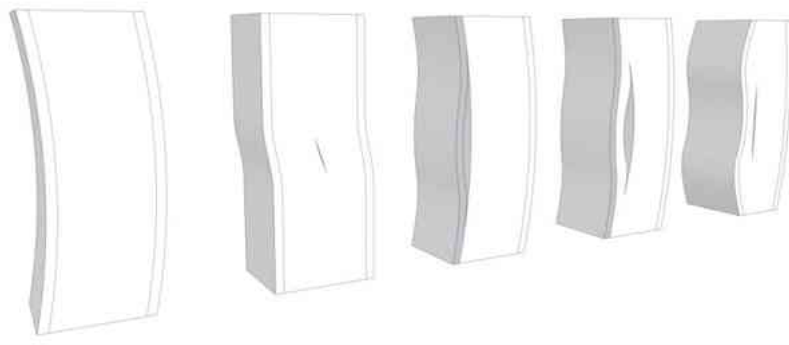

Figure 43: From left to right: Euler buckling; crimp; three types of wrinkling (based on [3])

Here it is stated that the nature of a sandwich structure leads to a multiplicity of possible failure modes under a buckling load. A few have been described in Figure 43.

A panel can elastically buckle outwards. Damage can also occur, however, in the bond between skin and core, so that the buckling resistance of the skin is actuated separately. This is much lower than the buckling resistance of the sandwich. Buckling of one of the skins can also lead to tearing out of the core (skin buckling outwards) or indentation damage of the core (skin buckling inwards). In the case of a honeycomb core, the skin can buckle locally between the walls of the honeycomb. This is called dimpling (Figure 44).

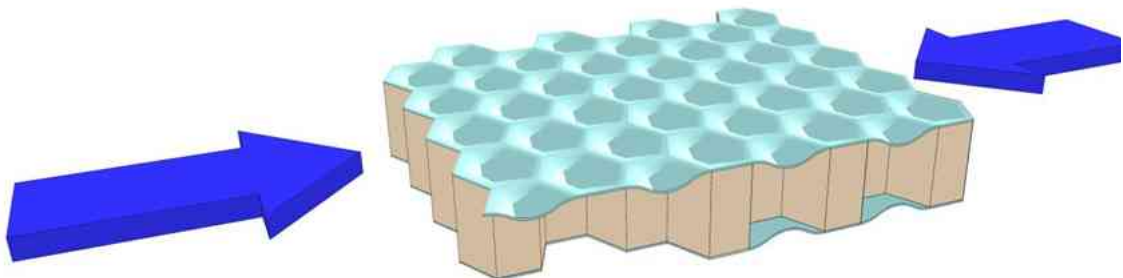

Figure 44: Dimpling of sandwich with honeycomb (based on [3])

4 - 3 Sources

- [1] DIAB Sandwich Handbook, version 09-03
- [2] Zenkert, D., (editor), 'The Handbook of Sandwich Construction', EMAS 1997
- [3] Caprino, G., Teti, R., 'Sandwich structures: Handbook', Il Prato, 1989

4 - 4 Exercises for this chapter

1. Demonstrate, using the formulas given in this chapter, that the values in the bottom table are realistic.

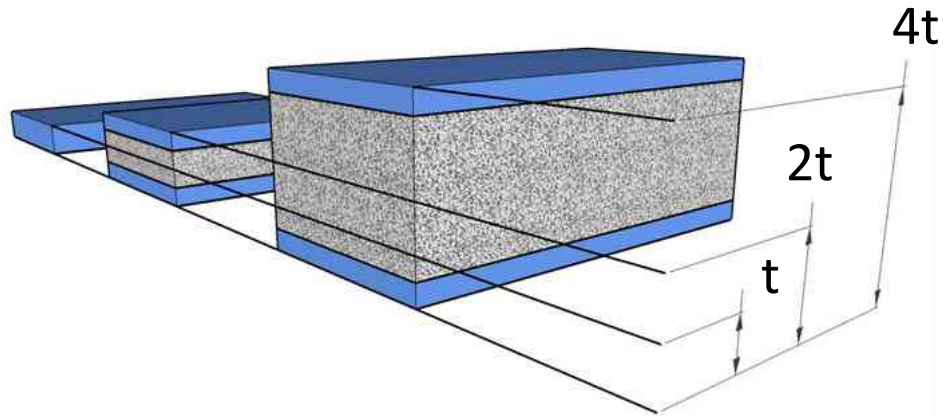

thickness	relative flexural stiffness	relative flexural strength	relative weight
t	1	1	1
2t	7	3.50	1.03
4t	37	9.25	1.06

2. What has been omitted in calculating the values for the row 'Relative stiffness'?
3. Name three advantages and four disadvantages of sandwich materials
4. For a typical pedestrian bridge, two possibilities are considered for the supporting structure: one with two steel girders and another based on a sandwich variant (glass fibre-reinforced polyester with PVC core). The bridges have identical dimensions: a width (b) of 2 metres, a span (L) of 5 metres and a construction height (h) of 305 mm. The data of the two steel I-sections and of the used sandwich are shown in the figure and table. The deflection of bridges must be smaller than $1/250$ th of the span.
 - a. Calculate the maximum load in the steel variant as a result of a load P in the middle of the bridge. Calculate the normal and shear stress in the steel section.
 - b. In which direction do most fibres lie in the skins of the sandwich?
 - c. What are the deflection and the stresses in the sandwich variant for this load? What do you notice?
 - d. Which measures do you propose to reduce the deflection of the sandwich bridge? Which is the most effective?

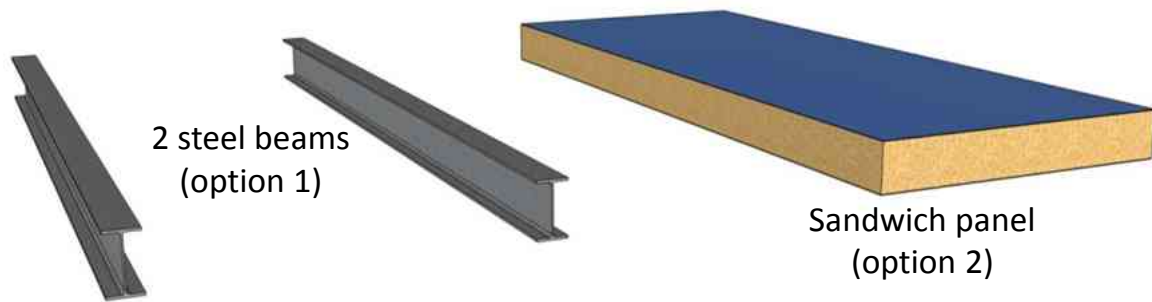

Parameter	symbol, unit	Option 1	Option 2
Moment of inertia	I, mm^4	116860000	
Bending rigidity (EI)	D, Nmm^2		$1.52391 \cdot 10^{13}$
Area	$A, A_{\text{skin}}, A_{\text{core}}, \text{mm}^2$	6830	16000, 594000
Density	$\rho, \rho_{\text{skin}}, \rho_{\text{core}}, \text{kg/m}^3$	7850	1800, 60
Stiffness	$E, E_{\text{fibre}}, E_{\text{core}}, \text{N/mm}^2$	210000	30000, 1000
Shear modulus	$G, \text{N/mm}^2$		1000
Mass per meter	$q, \text{kg/m}$	53.6 (per beam)	64.4

Interconnecting fibrous materials is not trivial. Composite designers are rediscovering age-old techniques such as knotting, splicing, braiding... When selecting a connection method it is sometimes just a matter of cutting the knot.



Chapter 5

Joints

Bonding is both the basis and the Achilles' heel of a composite structure. You will learn the principles of the relevant mechanical and adhesive joints, their weaknesses and the ways in which joints can be improved.

Composite parts must often be bonded to structural members made of another material. In addition, the situation can arise where composite parts have to be bonded to each other. The first is often unavoidable. It is preferable to avoid the latter however. Bonding composite parts to each other will make the structure more complex, heavier and more expensive than when an integral structure is made (without joints). In almost all joints, fibres are interrupted. This means that stresses occurring in the structure must be transferred through the adhesive via shear stresses.

Joints can be classified on the basis of different criteria:

- Detachable non-detachable
- Bonding of non-cured laminates (primary, wet-on-wet) cured laminates (secondary)
- Between similar different types of materials
- Mechanical adhesive

This chapter is mainly discusses mechanical and adhesive joints.

5 - 1 Adhesive joints

5 - 1.1 Making good adhesive joints

A good adhesive joint is dependent on good preparation and design. Firstly, the quality of the adhesive joint is determined by good workmanship. This implies pre-treatment (by cleaning and if necessary sanding) of the objects to be bonded, and application of the adhesive in the correct way and under correct temperature and moisture conditions.

Further, a good adhesive joint is designed such that the adhesive is principally loaded in shear. The tensile strength of an adhesive joint is generally lower than the shear strength. Peel stresses (stresses perpendicular to the adhesive joint that rely on the tensile strength)

must thus be prevented. Figure 45 shows examples of different types of adhesive joints. It also shows how good and bad adhesive joints are designed.

Thus, a good adhesive joint is parallel and symmetrical relative to the line of action of the forces acting on it. Eccentricity should be avoided. As shown in Figure 46, for example, deformation of the joint should be taken into account. This figure shows that secondary bending of the structure can cause peel stresses.

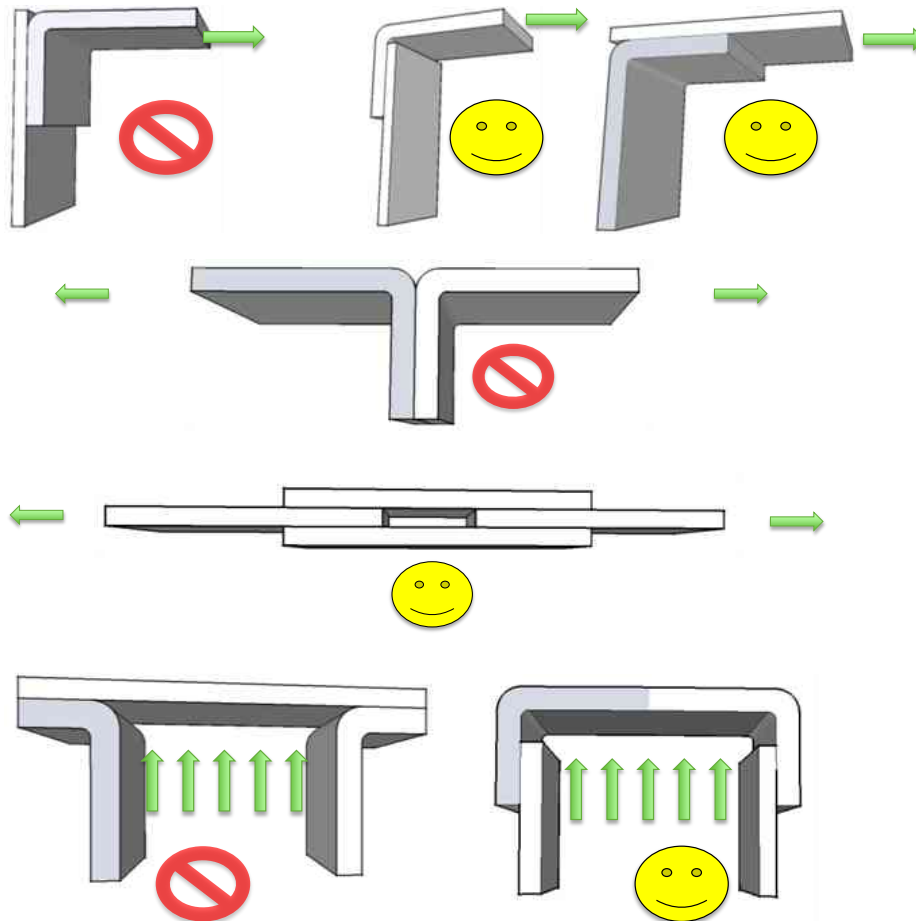

Figure 45: Designs of adhesive joints

Peak stresses often occur at the edges of an adhesive joint by stiffness transitions from the structural member to the adhesive (e.g. Figure 47). These stiffness transitions can be reduced by matching the stiffness of the adhesive and the laminate as closely as possible, e.g. by using a more rigid adhesive and/or adapting the fibre direction of the plies to be bonded. A flexible adhesive, however, has the advantage of redistributing peak stresses faster. Stress concentrations also arise because an adhesive joint is often combined with a geometrical transition. The lower the shear stress in the adhesive, the lower the peak stresses. These are proportional to the average stress. The larger the adhesive surface, the better.

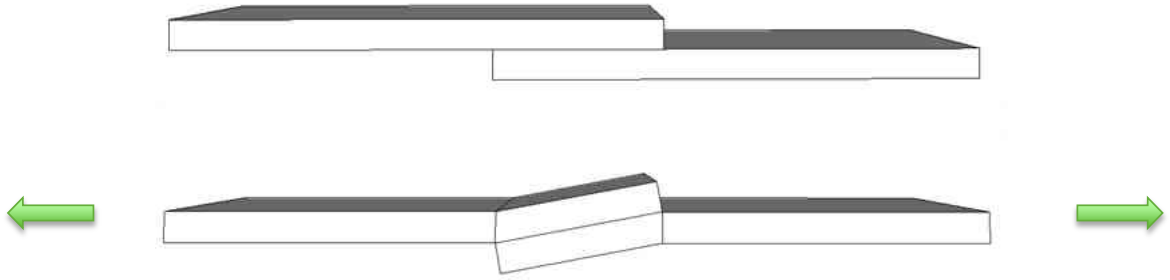

Figure 46: Deformation (inducing peel stress) in a single lap joint through secondary bending

An adhesive layer is generally a fraction of a millimetre thin. In large structures (bridges, wind turbine blades), thicker adhesive layers are often used. These can be up to a few millimetres thick. The behaviour of an adhesive joint is dependent on adhesive thickness. A thicker adhesive layer can distribute stress concentrations better internally, but will render the structure weaker than a thin adhesive layer. A thick adhesive layer is more difficult to apply, because of the low viscosity of many adhesives. For this reason, a filler (e.g. very short glass fibres) is often added to the adhesive for thick adhesive layers (>0.5 mm). The adhesive is then referred to as bonding paste.

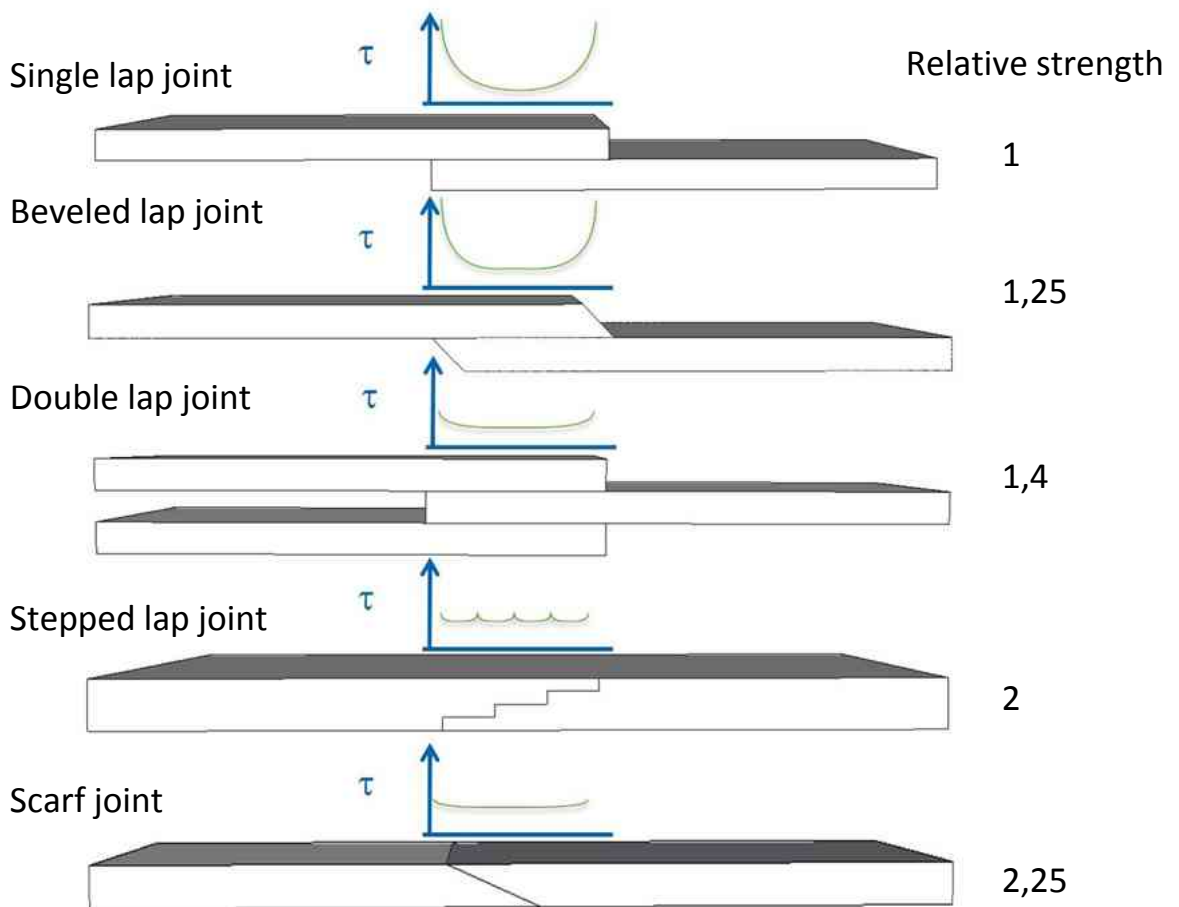

Figure 47: Shear stress distributions and relative strength of an adhesive joint (based on [1])

5 - 1.2 Failure of adhesive joints

An adhesive joint can fail through excessively high stresses or poor design. The failure mechanism may point out the possible cause. A distinction is made between adhesive and cohesive failure of adhesive joints (Figure 48). In the event of adhesive ('stick on') failure, failure occurs at the place of the bonding between the adhesive and the component to be bonded. Adhesive failure can be prevented by proper pre-treatment (cleaning and drying, degreasing). Adhesive fracture can be avoided by ensuring that the components have a correct roughness. Correct surface roughness provides a larger contact surface. Excessive roughness causes air inclusions (voids). Adhesive failure occurs less readily if the parts to be bonded are porous. This is due to the mechanical anchoring effect of the adhesive in the pores.

A cohesive ('cohesion') fracture occurs in the adhesive. The cohesion strength is determined by the type of adhesive, possible curing shrinkage, the porosity of the adhesive layer due to solvent evaporation (when bonding with solvent), any entrapped air, and the homogeneity and correct ratio of the components (for mixed 'two-component' adhesives).

If one of the structure's components shows no or little residual adhesive upon failure of an adhesive joint, the fracture is likely to be adhesive. In that case, it must be checked whether pre-treatment was carried out correctly and/or whether the adhesive was suitable for the component to be bonded. Cohesive fracture indicates that the adhesive itself was weaker than the joint between adhesive and structural component. Often, a mix of these types of failure occurs. Upon failure of a lap joint, exposed ply fibres are often visible. In that case, adhesive fracture has occurred between matrix material and fibre reinforcement. This leaves little room for improvement of the adhesive joint itself.

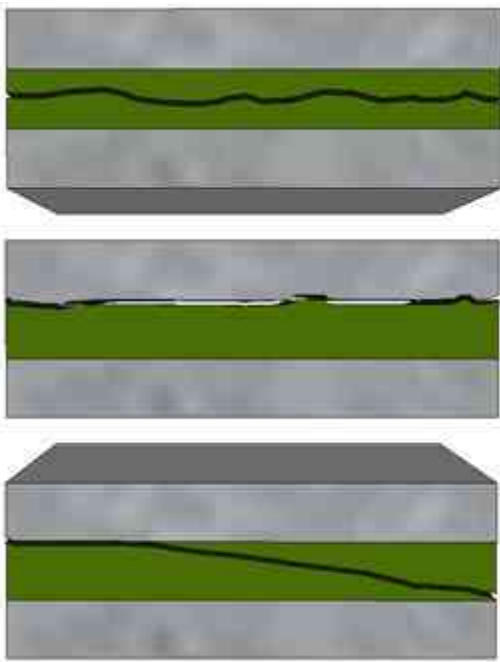

Figure 48: Failure modes of adhesive joints (from top to bottom: cohesive, adhesive, cohesive-adhesive)

5 - 1.3 Types of adhesive

The choice of adhesive type is very important. In addition to the mechanical properties, processing methods and, of course, the costs, it is important to check whether the adhesive is suited to the surfaces to be bonded. This is a matter of adhesion. You should take into consideration that material to be bonded may be soluble in the adhesive.

There are three adhesive types:

- thermoplastic ('hot melt') adhesives
- mixed or two-component adhesives (polymerisation adhesives)
- adhesive solutions (which cure under emission of a volatile solvent)

5 - 2 Mechanical joints

In the case of mechanical joints, no adhesive is used. Mechanical joints are generally of the 'pin-loaded hole' joint type. Making holes in a composite structure has consequences.

5 - 2.1 Surface pressure and stress around a hole

In the case of a pin-loaded hole joint that is loaded in the plane of the laminate, the pin – which can be a rivet, a dowel pin or a bolt – will rest against the hole edge and exercise surface pressure on it. Screw or bolt thread that rests against a hole edge will damage the hole edge. The surface pressure is dependent on the fit, laminate structure and possibly lateral support of the hole edge (e.g. by washers).

In addition to surface pressure, a stress concentration occurs in the laminate. This is located in the net cross section – i.e. the stress cross section minus the area of the hole – on both sides of the hole. This is quantified by the stress concentration factor. This is the factor by which you must multiply the stress in the remaining cross section. In metals, this factor is between 2 and 4. In composites, this factor can be higher: between 1.5 and 7(!). The reason for this is that metals show plastic deformation at the edge of a hole. This may result in increased elongation, but not in increased stress levels within the material. This plastic behaviour hardly ever occurs with composites.

5 - 2.2 Failure of mechanical joints

In Chapter 3, some possible failure modes of a composite were discussed. Bolted connections have the following characteristic types of fracture (Figures 49 and 50):

- **Tensile** fracture in the net cross section as a result of stress concentration;
- Failure due to **bearing pressure**. This is the most favourable type of fracture (the most 'forgiving'). The strength can be raised by supporting the laminate in the thickness direction. Washers can be used to achieve this;
- **Fatigue fracture**. On the contact surface between bolt and hole, the fibres fail very locally on pressure. As a result, the bolt fit is partially lost and redistribution of the load over the bolted joint occurs;
- **Shear fracture**. This type of fracture can be prevented by increasing the end distance and adding fibres in the $\pm 45^\circ$ direction;
- **Creep**. The pretensioning in a bolt can decrease through stress relaxation in the laminate. This can have a negative influence on the quality of the joint.

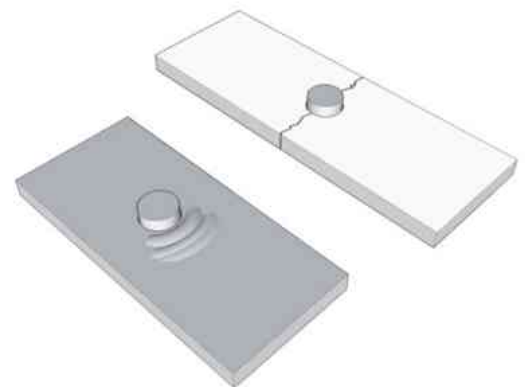

Figure 49: Failure under surface pressure and fracture in the net cross section

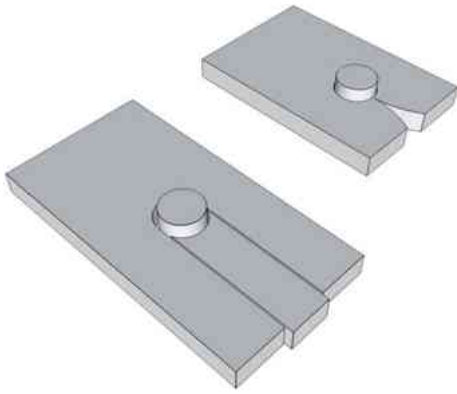

Figure 50: Lateral shear fracture and split fracture

5 - 2.3

Use of inserts

For various joints, it can be useful to fix a piece of metal, wood or composite in one of the components to be connected. This is generally done to improve the distribution of the stresses introduced by a bolt or screw. Inserts are used with laminates, but are often particularly necessary in sandwich laminates. Such an insert is generally built into the laminate or sandwich during the production of the part to be connected or bonded later (Figure 51).

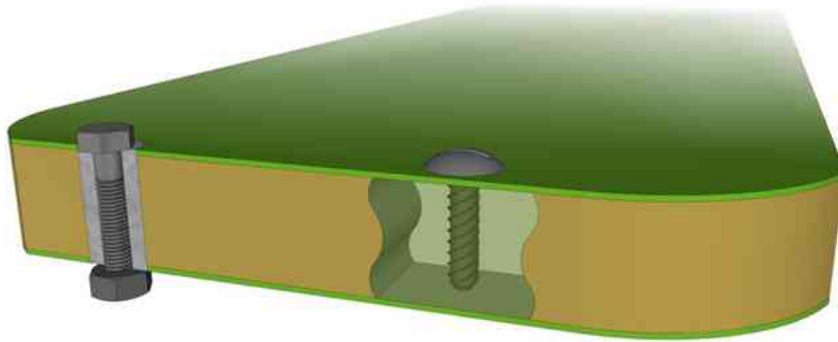

Figure 51 Inserts in a sandwich panel

5 - 2.4

Screwed connections

For fibre-reinforced polymers, a threaded joint can be made, just as for wood and soft materials, where the pitch and thread height are fairly high. The strength and detachability of such a joint can be considerably improved through the use of inserts.

5 - 2.5

Bolted connections

A bolt with nut (and if necessary a washer) has the advantage of the joint being detachable. Also, pretensioning can be provided in the bolt, so that laminates and plies are pressed on each other. This strengthens the joint through improvement of the resistance against failure under surface pressure, impeding delamination and distribution of the stresses across the panels.

Bolts are generally provided perpendicular to the plane in laminates. In thick laminates, it is possible to provide a joint in the laminate plane by using T-bolts or inserts.

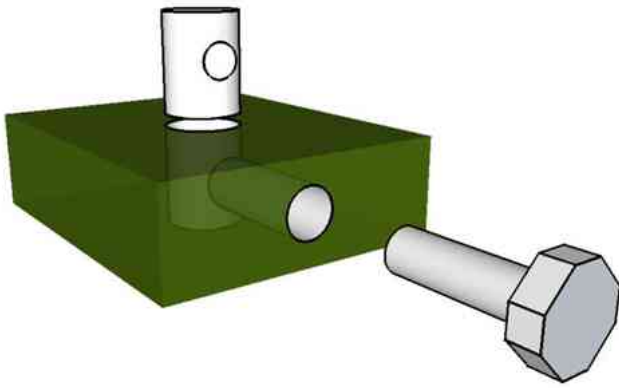

Figure 52: Joint in the plane of the laminate (T-bolt or 'Ikea joint')

Due to the similarity with a joining technique commonly used by a well-known Swedish furniture company, this joint is also referred to as an 'Ikea joint'. The preliminary processing for the joint is limited and simple, and considerable pretensioning can be achieved.

A similar joint which needs no barrel nut is the insert. This often consists of a sleeve with an internal screw thread that has been built into the laminate (or is provided later by drilling a hole and bonding). Pretensioning can be applied to this joint, depending on which part of the internal screw was threaded. If many bolts are to be used in a joint, more of these insert-joints will fit in a cross section than T-bolted connections (see Figure 53).

5 - 2.6 Hybrid and other joints

There are still many more joints in use. An obvious combination is that of adhesive and mechanical means. Such joints are sometimes referred to as 'hybrid'. In this case, the mechanical joint provides the contact force for the adhesive. Sometimes this can lead to shorter production times. The adhesive can compensate for manufacturing tolerances or have the effect of making the joint liquid- or gas-tight.

So-called injection bolts also exist. These permit the space between the bolt wire and the hole edge to be filled after installation of the joint. This prevents the thread from 'eating' into the composite. No threadless bolts are required at the hole wall location. Injection bolts can provide major advantages with respect to fatigue.

A mechanical joining technique commonly applied in

A T-bolt is shown schematically in Figure 52. For the T-bolt, two holes must be drilled in the laminate: one in the plane of the laminate (for the bolt) and one perpendicular to the laminate (for the barrel nut). Due to the similarity with a joining technique commonly used by a well-



Figure 53: Joints in the plane of the laminate by means of an insert at the blade division location [2] and at a blade root of a wind turbine rotor blade (source: TRES4/EOZEN)

bridge building and aircraft engineering involves the use of rivets. For composites, particularly for applications in aircraft engineering, special rivets have been developed with which high loads can be transferred.

All of the above-mentioned joining techniques are based on connecting two separate components, after production of the components. In the case of composites, of course,

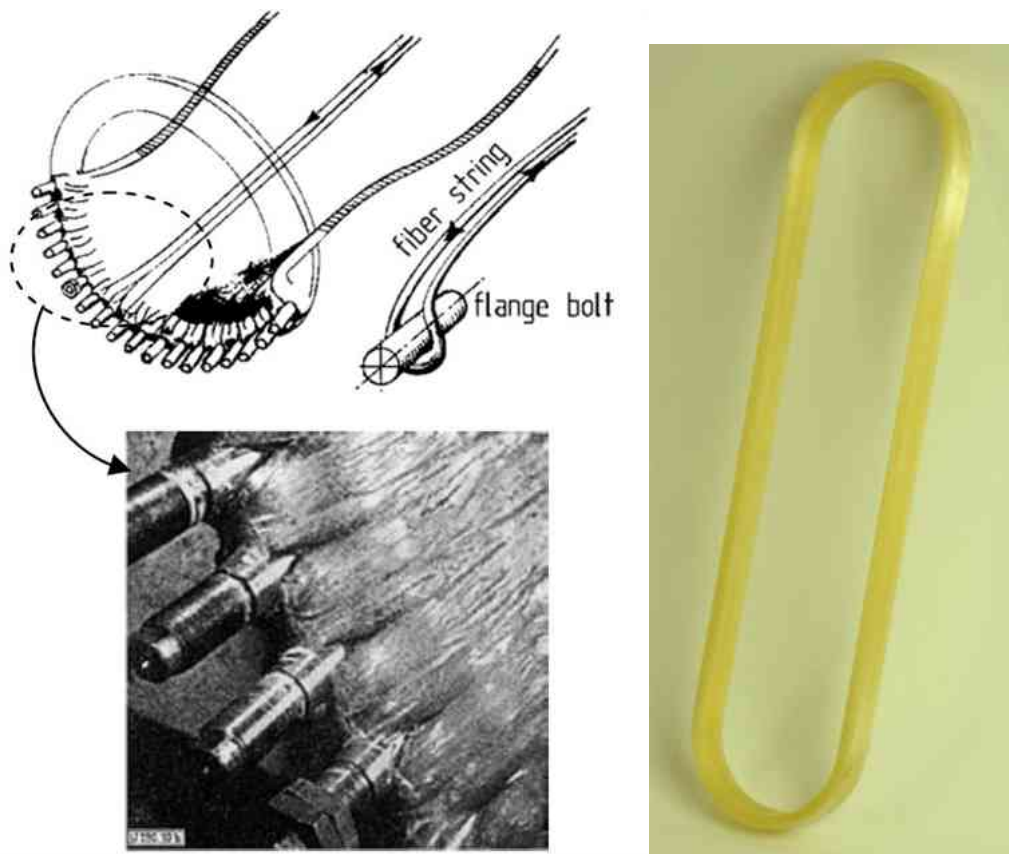

Figure 54: Hütter loop joint in wind turbine blade root ([3]) and strap (source: Futura Composites)

the joint can also be made 'on the job', e.g. by providing a number of coupling layers.

A composite can even be carried out as a loop, in which the part to be connected is either involved or not involved in the composite manufacturing process. A few examples are the 'Hütter' blade root joints for wind turbine blades – a design that is not often used nowadays – and the composite 'straps', with which superconducting magnets can be held in place under cryogenic circumstances (Figure 54)).

5 - 2.7 Joints in thermoplastics

For composite materials in which use is made of thermoplastics, use can be made of the 'weldability' of thermoplastic materials instead of adhesive bonding. The components to be connected can be heated on the spot, so that the plastic melts. By fixing and allowing the plastic to solidify, the parts are then 'glued' together. On-the-spot heating of thermoplastics can be performed in all kinds of ways. For instance, heating can be done using infrared light, microwaves or resistance and induction welding. In the last two cases, a strip of metal gauze is included in the parts to be connected (Figure 55).

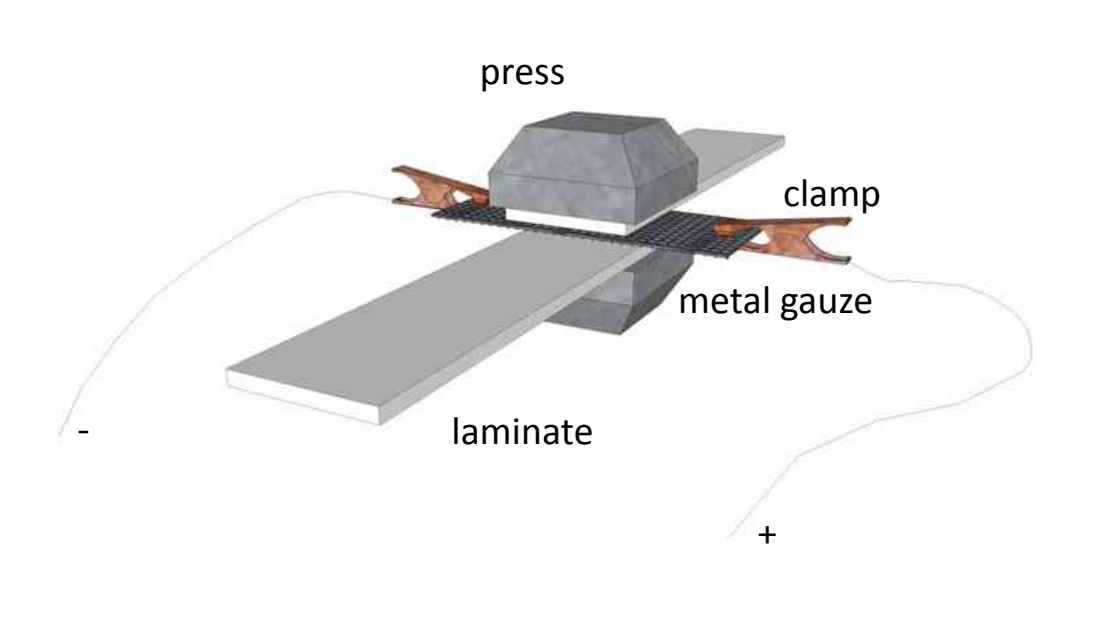

Figure 55: Welding of thermoplastics (based on [4])

5 - 3 Sources

- [1] R. van de Ven, *Composietmaterialen (Composite materials)*, Stam Techniek, 1993, ISBN 90-401-0073-X, (Figure 9.4)
- [2] van Wingerde, A.M., van Delft, D.R.V., Molenveld, K., Bos, H.L., Bulder, B.H., and de Bonte, H., 'Bladeco, windturbine bladen van ecologische materialen (wind turbine blades from ecological materials)', final report (public, in Dutch), May 2002
- [3] Copy of Figure 2.11 from Joncas, S., 'Thermoplastic composite wind turbine blades – an integrated design approach', dissertation, TU Delft, 2010 (ISBN 978-2-921145-73-2). Original figure from: Hau, E. *Wind turbines: Fundamentals, Technologies, Application and Economics*. Second edition, Springer-Verlag, Berlin Heidelberg, 2006
- [4] Stavrov, D., Bersee, H.E.N., Thermal Aspects in Resistance Welding of Thermoplastic Composites. Proceedings of ASME Summer Heat Transfer Conference, Las Vegas, USA, July 2003

5 - 4 Exercises for this chapter

- 1) *List in order of strength: double lap joint – slanting lap joint – a single lap joint – bevelled lap joint.*
- 2) *Name three advantages and three disadvantages of a pin-loaded hole joint in composite materials.*
- 3) *Name three advantages and three disadvantages of an adhesive joint in composite materials.*
- 4) *A pin-loaded hole joint is sensitive to different failure mechanisms. Give a possible remedy for the failure of a pin-loaded hole joint:*
 - a. *shear fracture*
 - b. *tensile fracture*
 - c. *split fracture*



An example of sustainable re-use of a construction?

Chapter 6

Sustainability

Sustainability in general, including the sustainability of composites, is a prominent discussion theme nowadays. Quantifying the environmental burden of structures is a new and complicated specialisation. This chapter broadly examines the environmental impact of composites and composite structures. It offers some pointers for further study. An important aspect is that each structure must be considered over its whole life cycle. This also applies to its environmental impact.

6 - 1 Life Cycle Analysis

For customers and producers, it can be interesting to compare the performance of products on the basis of environmental impact. Life cycle analysis (or LCA) is the collective term for methods which are used to examine the environmental impact of structures. In this regard, three life phases are distinguished [1]:

- production
- use
- end of life

LCA methods break a structure down into its components. They then determine how much material, energy and water is consumed per component. They also determine any emission of harmful substances. This is quite an in-depth process. A metal component, for example, requires iron ore to be mined and transported, and machines and labour to be deployed. This is all factored into such an analysis.

During its use, a structure must be regularly inspected and maintained. This requires energy. This is often accompanied by the emission of harmful substances.

A structure has a specific life cycle. At the end of its life cycle, a new purpose, application or destiny must be found.

LCA is based on the Life Cycle Inventory (LCI). This is a database which includes a specification of the environmental impact per material of structure. Such LCIs are compiled with care, but rely in part on assumptions. The quantity of heat that is released in the incineration of a particular quantity of material can be measured quite well, for example. The share of the commuter traffic of mineworkers or a maintenance crew can differ per situation, however. Such effects need to be estimated.

The result of an LCA can be expressed in different ways. A range of impact indicators is available. For example, the influence of a phase is expressed in tonnes of CO₂, energy consumption or in combined indicators such as the Eco or MKI score.

6 - 2 Sustainability of composites

The assumptions associated with an LCA are a source of discussion. For a new and diverse collection of materials such as composites, the available knowledge of the environmental impact is often relatively limited. There is quite some discussion about the environmental friendliness of composites, particularly with respect to their production phase and end of life phase.

In a recent VKCN press release [2], different comparative studies of bridges are discussed, for example. The conclusion is that more reliable and comparable environmental data must become available in order to be able to make an objective and valid comparison between different materials (Figure 56).

In general, composite structures offer various possibilities for low-energy design. Using them can provide significant environmental impact benefits. Various possibilities for low-energy design are discussed below.

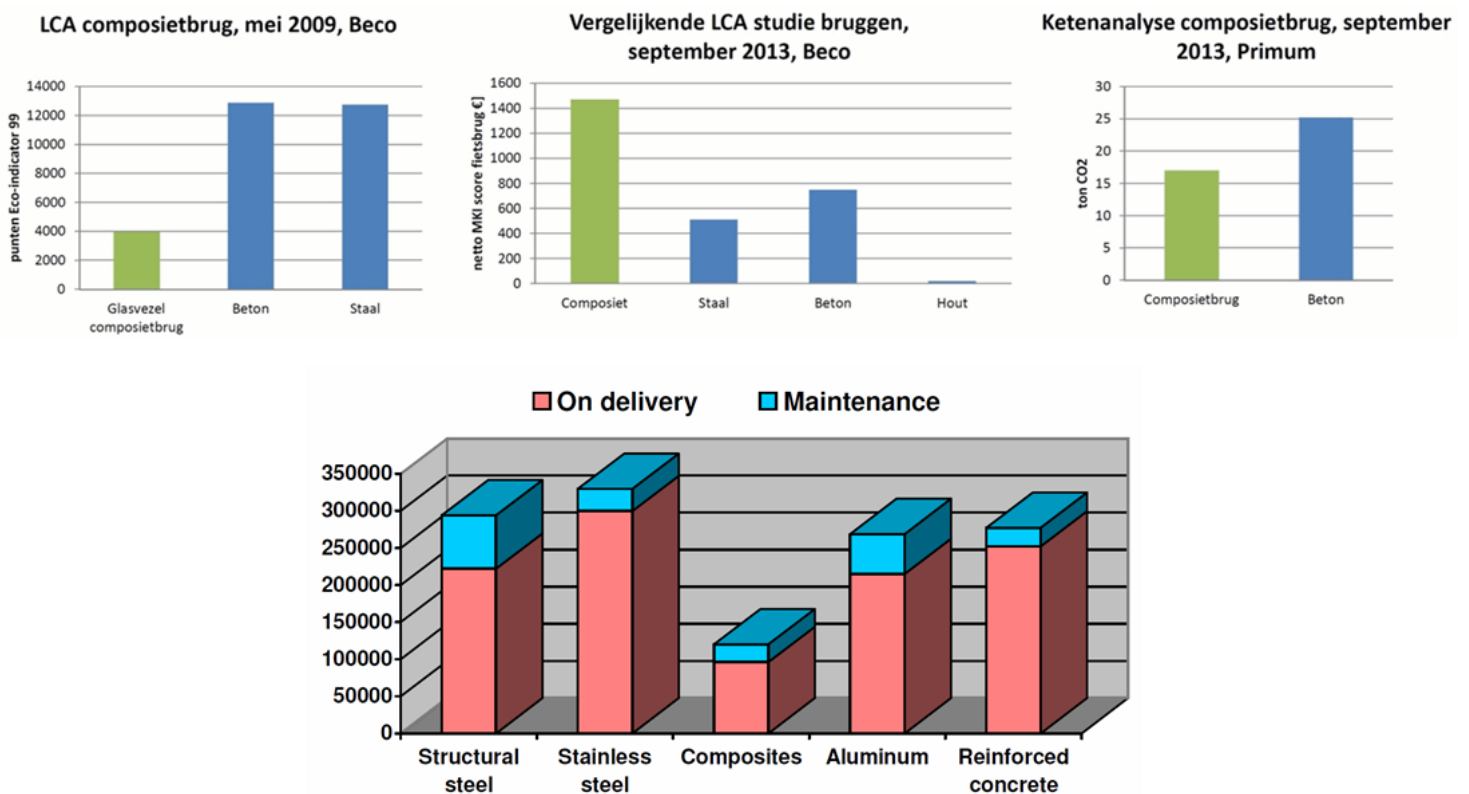

Figure 56: Different results of comparisons on bridges ([2], [3]). The vertical axis in the lower figure shows energy consumption in MJ

6 - 2.1 Production of composites

In general, a composite consists of fibres and a polymer. As discussed in Chapter 1, the production of glass fibres and carbon fibres requires a considerable amount of energy.

In the case of carbon fibres, the amount of energy required is relatively large. Most polymers are made of petroleum.

It is possible to make composites from natural materials. Most resins can be combined well with natural fibres such as flax, hemp, wood or bamboo. The mechanical properties of natural fibres are in general lower than those of synthetic fibres. Isolating suitable reinforcing material from these biological resources can be fairly laborious. Also, an important disadvantage is the sensitivity to moisture during the manufacturing process. However, the relatively low density of these fibres often provides composites with a high specific strength and stiffness. Another benefit of natural fibres is that they are often very transparent, e.g. to radar.

To a lesser degree, matrix materials are available on the basis of natural resources. Instead of petroleum, vegetable oil can also be used for making polymers. An important problem in the use of natural resources for structural materials is the possible competition with food crops. Biocomposites thus partly face the same problems as, for example, biofuels.

In addition to the impact of producing the constituents of a composite material, different production methods will have different environmental influences. Production based on open moulds, for example, will deliver more emission of VOCs (volatile organic compounds) than a closed-mould. With closed-moulds, however, many aids are often used (e.g. vacuum film) that become waste after release of the product.

6 - 2.2 Maintenance and repair

On account of the materials used, composite structures will generally require less maintenance than steel and wooden structures [4]. Examples are known in civil engineering, where the life cycle of a concrete structure is extended by the external application of composite reinforcing materials, such as in Figure 57.

Repairing a composite structure generally involves the removal of the damaged parts and



Figure 57: Strengthening of a 'shear wall' (reinforcement wall that is widely used in earthquake-sensitive structures) with carbon-composite [5]

applying new layers (hand-lay-up, pre-preg, or vacuum technique). This can generally be done in-situ. Curing a repair can be done by means of an electrically heated blanket, for example. With the necessary expertise, 'cosmetic' repairs can be carried out well. In the case of high-loaded structures however, repairs will not always restore the original strength.

6 - 2.3 Energy saving in the construction industry

A recent development, popular with architects, is the application of composite exterior wall panels. These allow a large degree of freedom in architectural design, and make it possible to design original, low-weight structures. In renovation projects, this means that the existing support structures do not need to be strengthened, or only require limited strengthening. In new structures, the support structure can be designed on a light-weight basis. The good thermal insulation properties of glass fibres and polymers, and the possibility of implementing exterior wall panels as sandwich structures, contribute to low-energy building characteristics (see for example Figure 58 or [6]).



Figure 58: Installation of exterior wall panels in the construction of the Utrecht city council offices.

With a surface area of 24000 m² this facade, implemented by means of double-mould vacuum injection techniques, is, at completion, the largest in Europe. The thermal and acoustic insulation values are $R_c=11.5$ and 34 dB respectively (source: Polux)

6 - 2.4 Composites in motion

Composites are often applied in moving structures. A lightweight design can improve the energy-efficiency characteristics of a structure. An obvious example comes from the transport world. For shipping loads, you need a ship, train, aircraft or truck (trailer). The

energy consumption of all these types of shipping is related to the weight of the type of transport used. By saving weight, rolling- or water resistance is reduced. In 'automotive' applications, the fact that the structure is often subjected to acceleration or deceleration during travel also plays a role. Light-weight design will obviously result in energy savings. In this respect, two quantities play a role: fuel savings and the extent of the payload.

Assume for example that a truck-trailer combination can be made 5% lighter, and that this will save approximately 5% of fuel per ride. For 10 rides, the savings will also be 5%. If the savings in weight of non-paying load means that 10% more payload can be transported per ride, however, a reduction of 1 in 11 rides will be achieved. This will result in a savings of nearly 10%.

In applications where braking energy is stored in flywheels, a composite flywheel – thanks to its high specific strength – is a good option.

In industrial applications such as pick-and-place machines and robots, the production rate can be increased if lighter and stiffer materials are used for the components of the production machines. Depending on the product, investments in lightweight designs can be recovered through higher output.

The freedom of geometry offered by the use of composites can provide direct energy savings through aerodynamic design (e.g. the light-weight fairings on truck cabins). In transport applications in particular, light-weight construction can lead to energy savings, e.g. by applying composite materials [7].



Figure 59: This 'bioscooter', an electrically driven scooter made of biocomposite materials, was developed in a joint venture with Hogeschool Inholland.

6 - 2.5 **End of life**

When a composite structure is at the end of its life cycle, various options are available. The possibilities for composite structures are generally more limited than for traditional structures, however. Depending on the type of resin and reinforcement, recycling may be possible. Incineration in cement furnaces is a method recognised by the EU. Composite waste is inert and thus not more harmful than domestic waste [1].

6 - 3 Sources

- [1] Vereniging Kunststof Composiet Nederland, 'Composieten en Milieu (Composites and the environment)', fact sheet on designing with composites, part 11, March 2012
- [2] Vereniging Kunststof Composiet Nederland, 'Milieuvergelijkingen nog onbetrouwbaar (Environmental comparisons still unreliable)', press release, 3 October 2013
- [3] Ryszard A. Daniel, Ecological Analysis of Material Selection for a Bridge, IABSE Symposium report 12/2008, DOI: 10.2749/222137809796068307
- [4] Vereniging Kunststof Composiet Nederland, 'Civiele constructies en infrastructuur (Civil structures and infrastructure)', fact sheet, via www.vkcn.nl
- [5] www.lotus-inc.com
- [6] Vereniging Kunststof Composiet Nederland, 'Bouwproducten en inrichting (Building products and infrastructure)', fact sheet, via www.vkcn.nl
- [7] Vereniging Kunststof Composiet Nederland, 'Transport(besparing) met composieten (Logistic savings with composites)', fact sheet, via www.vkcn.nl



Unsuspectingly, this scientist runs onto the IJssel-lake, early January 2012. Despite the inconstant climate he assumes that the ice will carry him. Or did he spot his colleagues on the horizon, who already proved the ice's strength on their skates? Trust may be the basis of economy; in this case, testing might be better...

Chapter 7

Testing

Testing composite materials calls for a different approach than testing isotropic materials. This is due to fibre structure, the difference between tensile and compression properties and failure mechanisms of composites. After completing this chapter, you will have an overall understanding of the most important measuring and testing methods, and the similarities and differences compared to isotropic material testing.

7 - 1 Why test?

Testing a material or structure can be done in practice for a number of reasons. These invariably boil down to validating the assumptions that were made in the design stage. If the design stage of a structure includes predictions as to its deflection or eigen-frequency, you can assume a value for this stiffness, measure it from the raw material or measure the deflection or eigen-frequency of the structure and thus check whether your assumption was correct. There are different categories of tests:

- Quality control: does the material comply with the specifications stated by the supplier?
- Generation of input data for a design or design detail, e.g. testing the behaviour of a joint.
- Partial or full-scale test: a test on a scale model or a whole structure.

The category of the testing to be performed, as well as the test and measuring methods to be used, depend on the specific case. Does a product require certification? Then there is often a list of standard methods that must be used. Are you investigating the behaviour of a non-standard design detail? In that case you must sometimes develop your own test set-up and measurement protocol.

In all cases the test must, of course, be representative of real-life circumstances. The test method and the material to be tested, or the structure to be tested, must reproduce the stresses and elongations that can occur in reality as much as possible.

7 - 2 Test- and measurement methods for composites

This chapter discusses the measuring and test methods that are relevant for the properties of composites discussed in Chapter 3 in particular. In determining the properties of composites, many options are available. The value of the property to be determined may depend to a large extent on the measuring and test method that is chosen.

7 - 2.1 Test set-up and methods of measurement

For an example of a test set-up, see Figure 60. In the case of a coupon test – a coupon is generally a strip of the material to be tested and is also referred to as a test piece or specimen – the test set-up may include various elements. First of all the test piece will have a particular geometry, depending on the test method and purpose. The test piece is fixed in the test machine by clamping jaws or a dedicated accessory. In series with – or incorporated in – one of the clamping jaws, there is often a sensor that measures the applied force. The hydraulic or spindle jack(s) generally include a sensor that measures the displacement of the clamping jaws. These built-in force and displacement sensors are also used for the actuation of the test machine. If the cross section of the coupon is known, the average stress in the cross section can be calculated. The displacement speed during a test is often prescribed by a standard. This is then set and documented by the displacement sensor. The displacement signal from the built-in sensor generally has little meaning for the evaluation of a test. This is because the measured displacement is the total of the coupon deformation and the deformation of the test machine. This latter value can be relatively large.

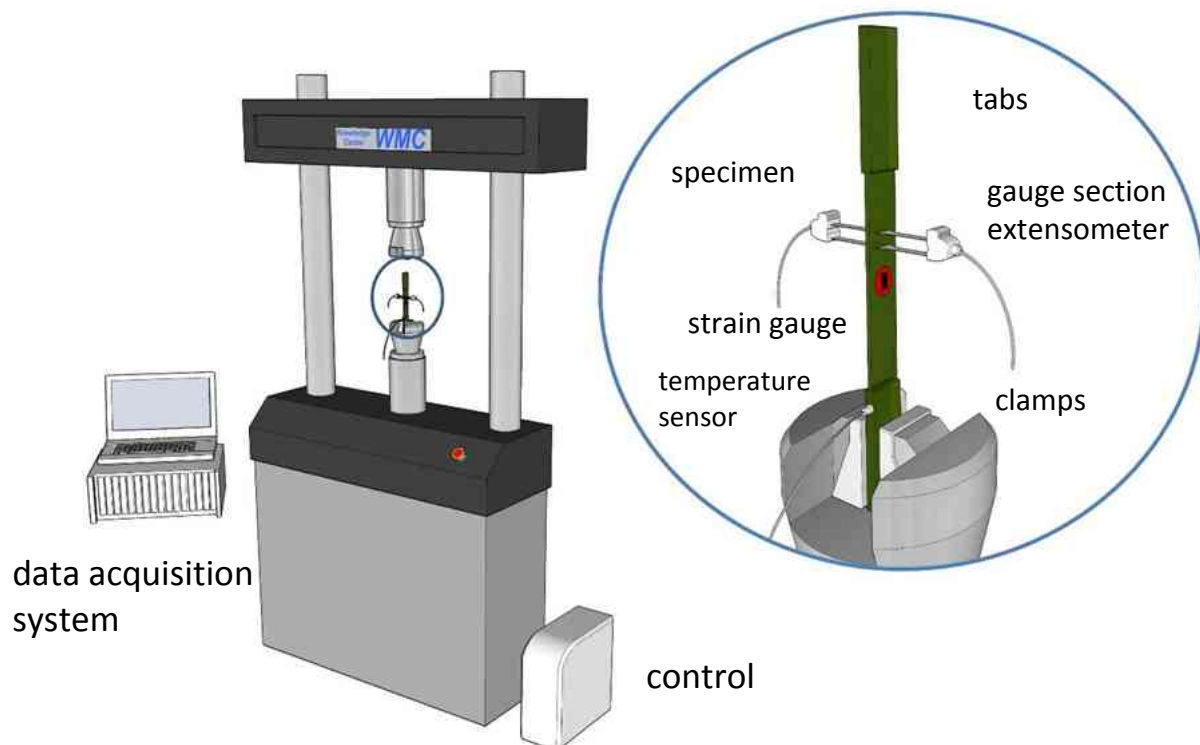

Figure 60: Test set-up for material tests (source: WMC)

Added force and displacement transducers can be used to collect more information on the behaviour of the coupon.

Strain is an important quantity. Together with the force, it is translated to the stiffness (the E modulus). A commonly used method to measure the strain is using a strain gauge. This is a thin metal wire that lies folded up on a plastic support (see Figure 61). If the support is subjected to an elongation, the wire becomes longer and thinner. As a result, its electrical resistance changes. By comparing the stress across the connection points of the strain gauge (after calibration) with the stress across known resistors (often a Wheatstone bridge is used), the mechanical elongation can be determined. The advantage of a strain gauge is that the sensor is relatively cheap and can be quickly applied by adhesive bonding. Disadvantages are that the sensor is not reusable and is often unsuitable for the large elongations that may occur in composites. The sensor is unsuitable for use with a fatigue load. Strain gauges

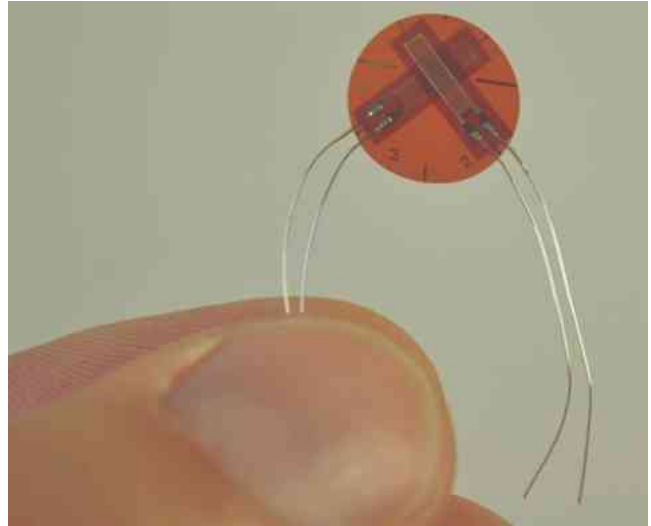

Figure 61: Multi-axial strain gauge (source: WMC)

are commercially available that can measure in several directions in the plane. This is useful for shear tests or for measuring transverse contraction.

There are many alternatives for the strain gauge. The most common is the extensometer. Although this sensor is based on strain gauges, it is reusable (see Figure 60). This sensor takes up more space and is often removed before the fracture point in fracture tests to protect it from damage.

In addition to the disadvantages mentioned, the above methods have the following disadvantages:

- the measurements are contact measurements: the test piece can be influenced by the sensors or by pretreatment for the application. Often the sensors are not capable of withstanding extreme temperatures or moisture;
- the measures are local measurements: the strain is measured only at the place of the strain gauge or extensometer, not beyond these points.

There are relatively new sensor technologies under development that do not have these disadvantages. These methods are based principally on optical techniques in combination with dedicated image processing software.

A relevant example is DICT (Digital Image Correlation Technique) (see Figure 62). Here a pattern is first applied to the coupon. It is very important that this pattern is as random as possible. Often the pattern consists of manually applied speckles (white background, black speckles with spray paint). There is also software that prints stickers displaying arbitrary patterns. A camera takes pictures of the coupon at different loads. Because elongation varies with load, the speckles move slightly. The speckle displacement is tracked by software. Since there are no fixed patterns in the speckles, the software is able to determine how a set of speckles is displaced under the influence of a load. The speckle displacement, and thus the local elongation as well, are known for the whole coupon being tracked. Sensors do not need to be clamped or bonded to the coupon. It is thus a non-contact, full-field technology.

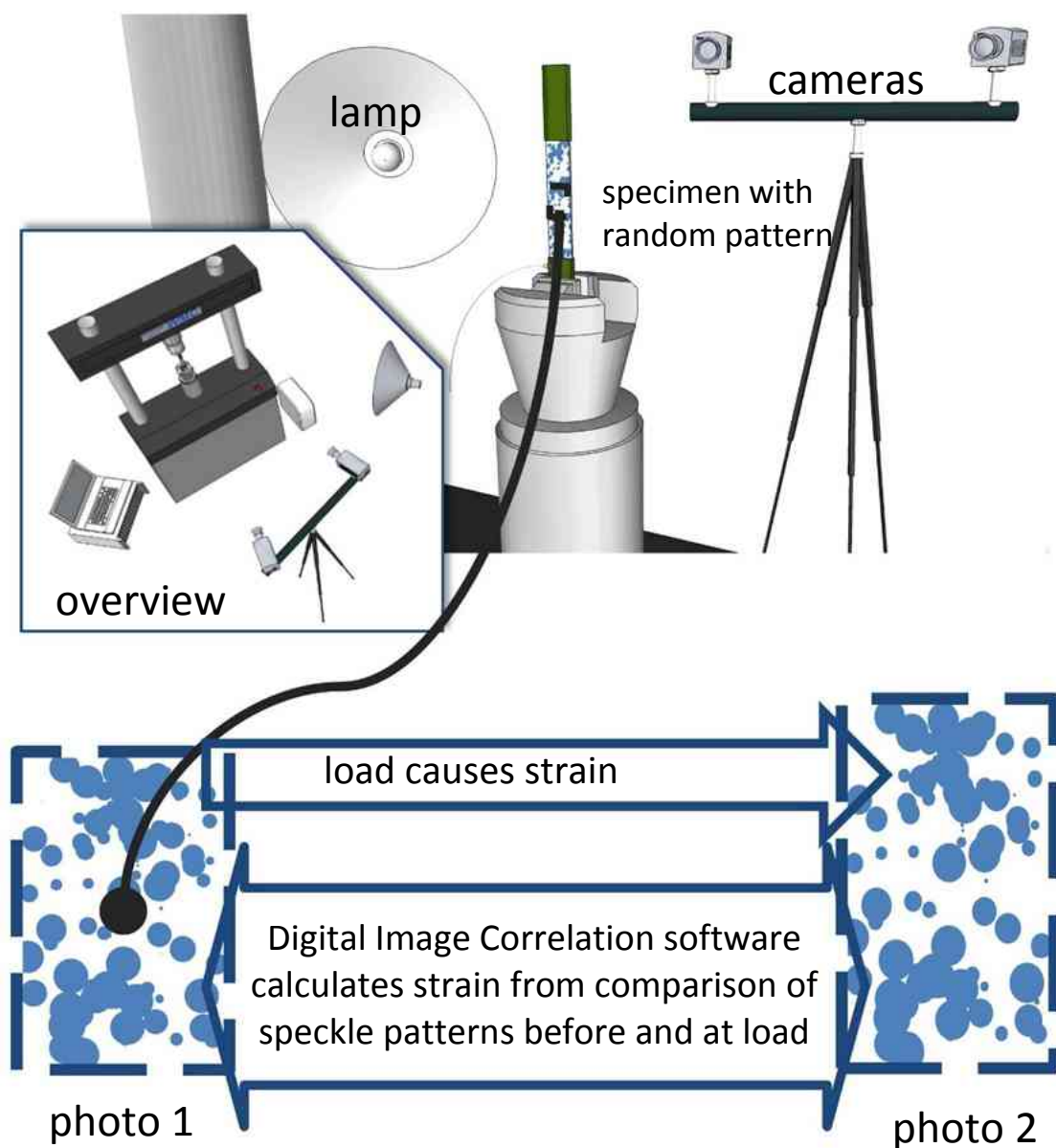

Figure 62: Overview of the Digital Image Correlation Technique (source: WMC)

The most important disadvantage in particular is the cost of the software. Some open-source software is available, although its usability is limited [1]. Further, the arithmetical operations involved are fairly time-consuming. The technology is therefore not suitable for real-time processing.

In addition to force, displacement and strain measurements, it is important to record the temperature and often also the humidity in the laboratory. For fatigue tests, the temperature of the test piece is important for determining the validity of a test. Heating of the test piece during the test can influence the life cycle and invalidate the test.

7 - 2.2 Types of mechanical tests

To obtain the mechanical properties of a coupon (and thus of a laminate), various tests can be performed. A number of factors must generally be taken into account in this respect.

First of all, providing the test piece with a reduced cross section in the middle does not deliver any benefit for UD composite materials in particular. This 'width tailoring' often takes place with metal test specimens to ensure that the maximum stress occurs in a predictable place. This allows any sensors that may be used to record the strain at break and stress accurately. Width-tailoring a laminate means either the application of thickness variation (where plies must be terminated) or the application of variation in width (where fibres are intersected) or a combination of these. Particularly at fatigue load, by delamination and axial cracking, a width-tailored test piece will become prismatic (Figure 63). In addition, the probability exists of damage to the laminate during width-tailoring. In this respect, water-jet cutting is the 'friendliest' method. This means that prismatic coupons are used in many mechanical tests.

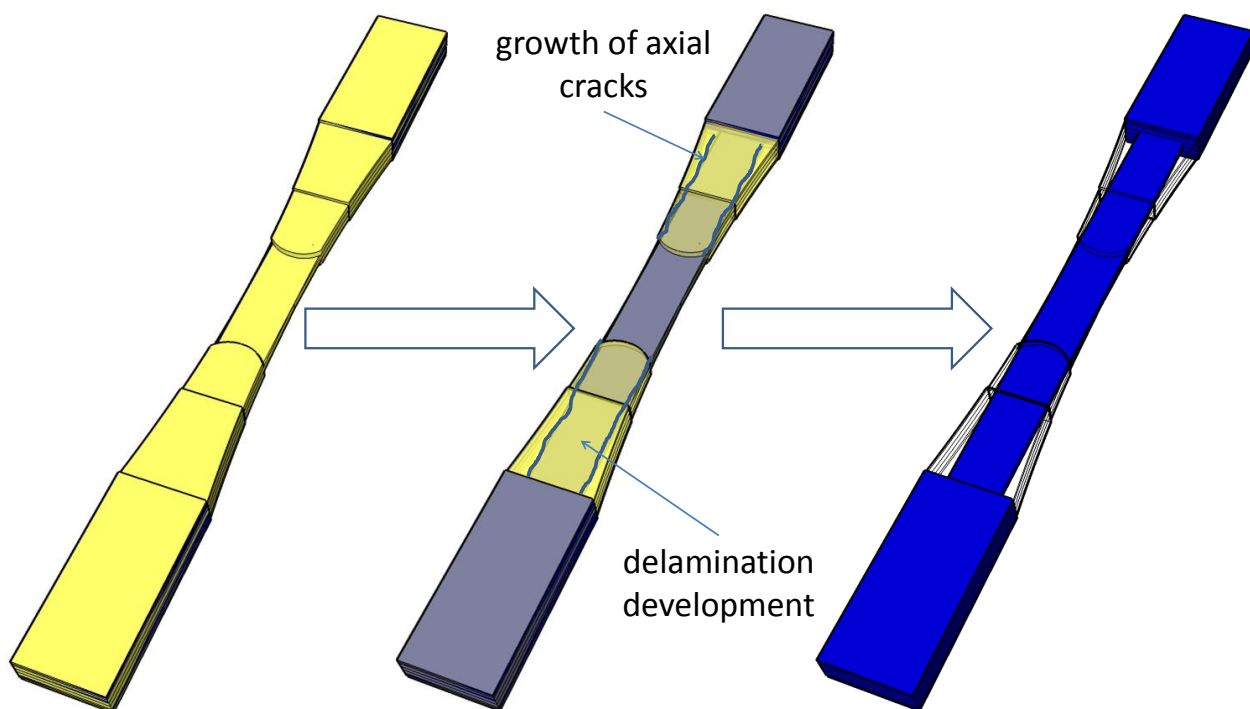

Figure 63: Creation of a prismatic test piece from a width- and thickness-tailored test piece of UD material

In prismatic coupons, it is necessary to allow for the influence of the clamping. The hard jaws of a test machine can cause damage to the test piece surface. Further, the laminate is depressed (by the clamps) and a shear stress prevails on the surface (the test piece is generally held in the clamping jaws by friction). In a prismatic test piece, there is a danger of the material breaking in the vicinity of the clamping jaws. This results in a lower strength value than what the material is really capable of, meaning the results are conservative. Often the ends of test specimens are provided with so-called 'tabs'. These are pieces of metal or composite that are bonded to the ends of the coupon to prevent damage to the surface. They reduce the probability of failure at the jaws.

In addition, most test machines are equipped with standard clamping jaws. For some test methods, an accessory is then necessary to be able to carry out the tests. This applies particularly to shear tests, but also to compression tests. The advantage of an accessory is that the test result is almost independent of the alignment of a test bench, for example. Many accessories are available, however. This means it may sometimes be difficult to find a comparable set of data for a specific laminate, since it is quite likely that the same laminate has been tested elsewhere using another accessory (see Chapter 1). The nature of the accessories can sometime influence the results and the type of sensors that can be applied.

7 - 2.2.1 Tensile test

A tensile test (for example [1]) is one of the simpler tests on a material. Since there are not many different standards, a comparison of tensile strengths is quite reliable for most laminates. A tensile test can determine the tensile strength, the stiffness, the Poisson contraction and the strain at break (Figure 64). Subjecting a $\pm 45^\circ$ laminate to a tensile test will allow its shear properties to be derived.

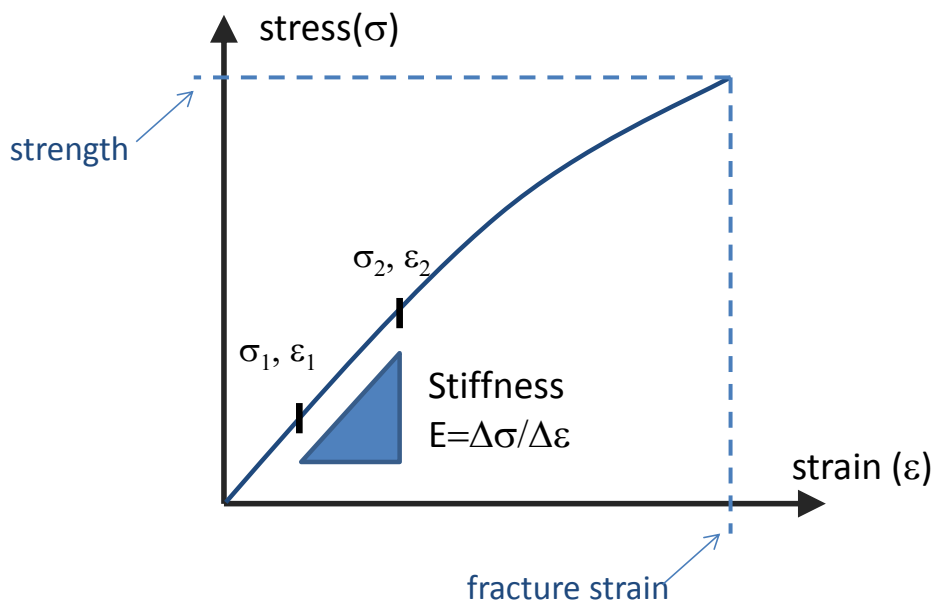

Figure 64: Properties from the stress-strain diagram of a tensile test

7 - 2.2.2 Compression test

The measurable compressive strength of a laminate is generally smaller than the tensile strength, while the stiffness is more or less equal. Although a compression test can be done using the clamping jaws of a standard test machine, there are various dedicated accessories on the market with which the quality of a compression test can be improved [2], Figure 65. Reasons for this can be:

- the measurement length is so small that the clamping jaws cannot close sufficiently;
- the clamping jaws protrude or extend, so that non-supported test piece length becomes too large;
- a separate accessory guarantees proper alignment of the clamped-in parts of the test piece;
- by means of the accessory, the compression load can be applied both by normal load on the test piece ends as well as by shear load in the jaws;
- the whole test piece length can be supported with an accessory, so that it does not buckle out.

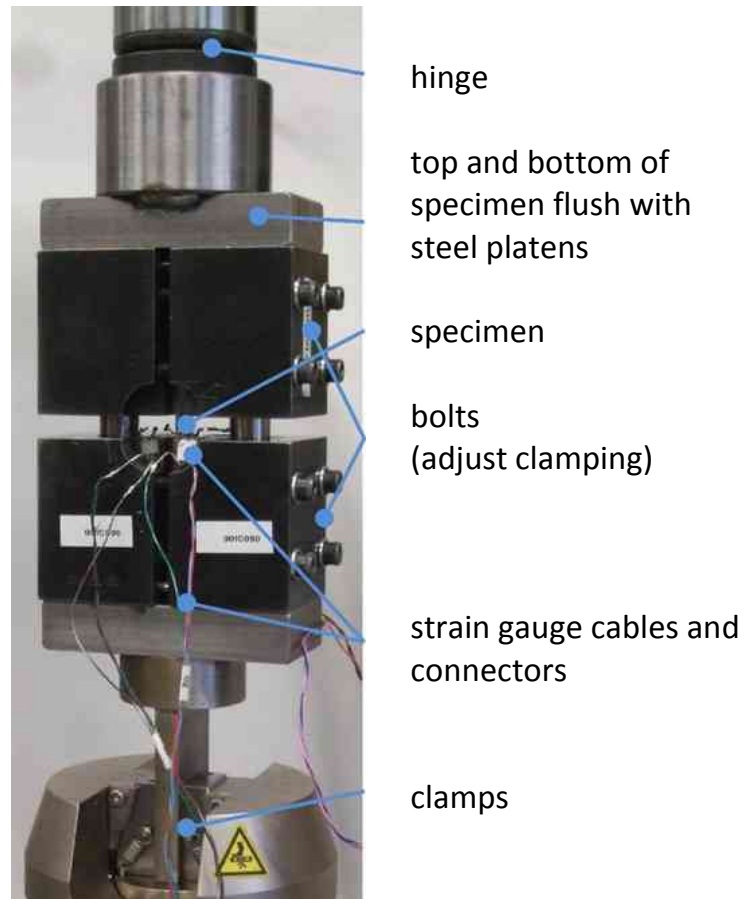

Figure 65: Compression test set-up with fixture

(source: WMC)

A laminate in a compression test will give less reliable values if fibres do not run sufficiently parallel to the load. The greater the deviation, the less reliable the results will be.

7 - 2.2.3 In-plane shear test

For thin-walled structures in particular, it is often interesting to know the shear properties in the plane of the laminate. There are various shear tests for determining this, e.g. [3] or [5]. An example is given in Figure 66.

During the test, the two clamps move in opposite directions. This creates a shear stress in the laminate. Often, the middle section of the laminate is narrowed. In a shear test, fibre orientation must be carefully chosen. For an anisotropic laminate, the shear strength can be measured in the plane in two different directions (and in the thickness direction).

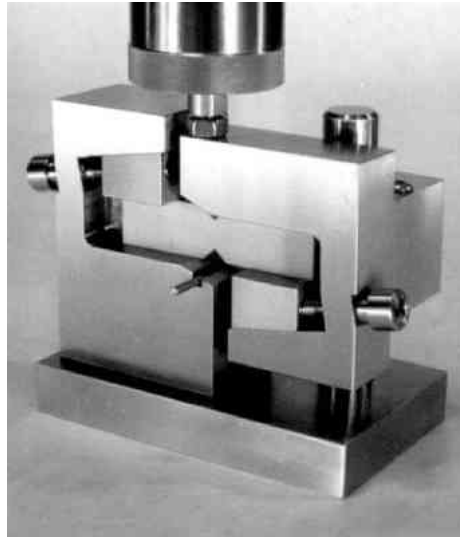

Figure 66: Fixture for the in-plane-shear test (source: [4])

7 - 2.2.4 Interlaminar shear test

In this test, the shear strength between the centremost plies of a test piece is determined (interlaminar shear strength). This is a simple test, for which one does require

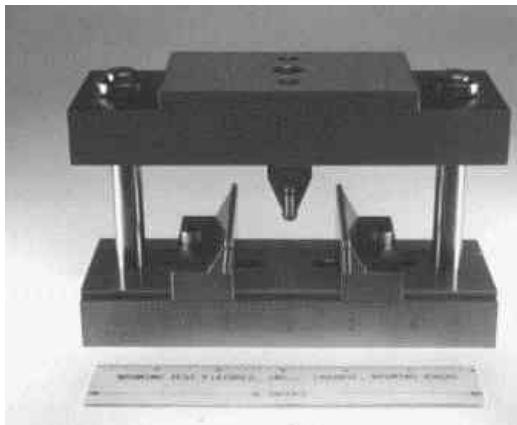

Figure 67: Fixture for the interlaminar shear test (source: [4])

a three-point bending accessory. In the laminate, a shear stress prevails that is highest between the centremost layers. These layers will shear off from each other and the result will provide information on the resistance against delamination, and thus also on the extent to which curing of the resin was successful [6].

7 - 2.2.5 Structures and structural details

Besides coupons, structural details or even whole structures can be tested. This is done later in the design

process, when the failure behaviour of a detail or structure needs to be checked. It then involves structures in which this behaviour (e.g. damage growth) cannot be predicted – or can scarcely be predicted – on the basis of the results of simpler coupon tests such as discussed above. Examples are the testing of a whole bridge, a complicated joint, etc. Technically speaking, these situations involve cases in which:

- the stresses are multiaxial;
- different materials have been mutually connected, causing large stress gradients to occur through the thickness;

- buckling occurs;
- there are relatively large 3-dimensional 'jumps' in the structure;
- fatigue plays a role.

7 - 2.3 Other tests

7 - 2.3.1 Fibre volume content and fibre mass content

It is important to know the fibre and resin content of a composite. This determines the performance of the composite to a large extent (see the section on the rules of mixture in Chapter 3, for example). The determination of the fibre and resin content of a composite is carried out by a number of weighing operations, before and after removing the resin. The simplest way to remove resin is by burning it away. This is often done in the case of glass fibre reinforced composites. The procedure for the determination of the fibre content is as follows. A small block of composite is weighed in 'dry' and 'wet' state. Weighing is done while the material is immersed in water. This allows the volume of the block to be calculated. The block of composite is then placed in a furnace with a gas outlet and heated. This burns away the resin, but not the fibres. The fibres are then weighed. For polyester or epoxy-reinforced composites, incineration at approximately 550°C for a few hours is usually sufficient to reduce the material to clean fibres (Figure 68).

The more assumptions that are made regarding the densities of the components, the more information this method will provide on the fibre content.



Figure 68: Accessories for performing fibre volume content measurement (source: WMC)

The fibre content can, of course, be determined without assumptions by dividing the weight of the fibre package with the weight of the composite:

$$FWF = \frac{m_f}{m_c}$$

Where:

FWF	=	Fibre Weight Fraction
m_f	=	mass of the dry fibre package (after incinerating the resin)
m_c	=	mass of the composite (before incinerating)

The fibre content follows from:

$$FVF = \frac{V_f}{V_c}$$

with:

FVF	=	Fibre Volume Fraction
V_f	=	volume of the dry fibre package (after incinerating the resin)
V_c	=	volume of the composite (before incinerating)

For this calculation, the volume V_c of the composite block is required. This can be determined by a wet weighing process in a liquid with known density, generally water. Since the density of water varies somewhat with the temperature, the temperature is also measured during weighing. The volume V_c follows from:

$$V_c = \frac{m_c - m_{c,w}}{\rho_w}$$

$m_{c,w}$	=	weight of the composite in water
ρ_w	=	density of water (depending on temperature)

The volume of the fibres follows from the mass and the density (this is often an assumption):

$$V_f = \frac{m_f}{\rho_f}$$

where ρ_f is the density of the fibres. Until now it has been assumed that the composite consists only of fibres and resin. It is not inconceivable, however, that it also contains other components, e.g. air inclusions (voids). In other words:

$$V_c = V_f + V_m + V_v$$

V_m	=	volume of the matrix material
V_v	=	volume of the air inclusions

This can be rewritten as:

$$V_v = V_c - (V_f + V_m)$$

The volume of the resin is determined from the difference between the mass of the original composite and the fibre package, and the – assumed – density of the resin.

7 - 2.3.2 Glass transition temperature

The glass transition temperature provides information on the usability of a resin at a given temperature. In addition, the measured value of the glass transition temperature provides information on the manufacturing process (see also Section 1 - 5).

Various methods are available for determining the glass transition temperature and related quantities. Roughly speaking, these can be categorised as mechanical-dynamic methods and thermodynamic methods [7], [8].

The best-known from the first category is called DMA (Dynamic Mechanical Analysis). In this method, the force and displacement are measured while a piece of composite is cyclically loaded and the temperature is gradually changed. When the force and displacement are plotted against each other, hysteresis appears at higher temperatures. This means that, as displacement increases and decreases, the force follows with some delay. This results in a kind of loop-shaped signal in a force-displacement diagram. The surface of this loop is a measure of the quantity of hysteresis. The hysteresis is also used as a measure of material damping, because it is concerned with the quantity of energy that is converted into heat by the material in each displacement cycle. At low temperatures, hysteresis will be close to zero (the material behaves elastically and force and displacement will be strongly proportionally linked). At higher temperatures, the material will show more rubbery or viscoelastic behaviour and hysteresis will increase. The glass transition temperature can be determined from the increases of this 'damping'. There are various DMA methods, e.g. a 3-point bending set-up or a torsion-bend. An advantage of this method is that there is a clear relationship between the glass transition temperature and the behaviour of the structure (namely damping). A disadvantage is that relatively much material and a fairly extensive mechanical test set-up are necessary.

In the other category, DSC (Differential Scanning Calorimetry) is mostly applied. Here the heat capacity of a test piece is compared with that of a known piece of material (built into the DSC equipment). During heating, the heat capacity of the test piece changes. The glass transition temperature T_g is then derived from this change.

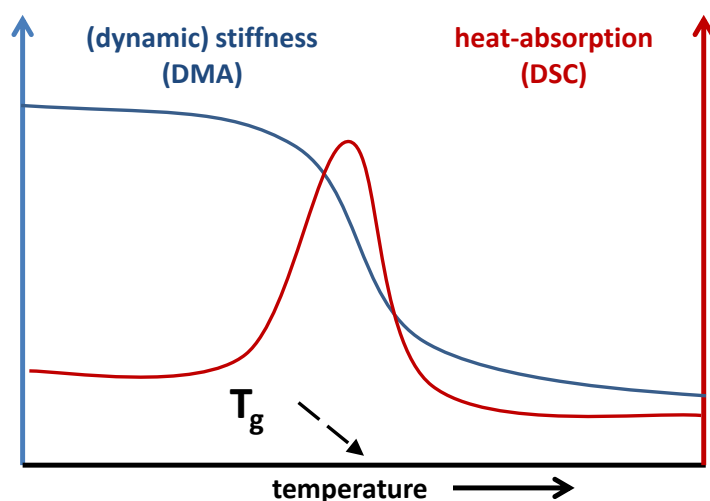

Figure 69: Measurement of glass transition temperature with DMA and DSC (shown schematically)

In a standard set-up, the advantage of DSC is that only a small quantity of material is used. One of the disadvantages is that the filling material content in a composite (e.g. the fibres) can provide a misrepresented image of the glass transition temperature, which pre-eminently is a property of the polymer.

In both methods, a certain amount of arbitrariness can occur in the interpretation of the test results. The glass transition temperature is generally not a discrete temperature. The transition of glass to rubbery behaviour takes place over a certain temperature range. For this reason, a series of glass transition temperatures is often given. In this case, the so-called 'midpoint' (middle of the transition area) is accepted as 'the' glass transition temperature. See also Figure 69.

7 - 3 Interpretation of test results

In this chapter, various measuring and test methods were described. The results are shown, for example, in a table specifying the strength and stiffness of a material (in a particular direction!). Such tables actually describe the behaviour of the material. This can then be used to optimise a design in terms of material use. A good engineer will review such material properties critically. There are different matters which you must bear in mind. These include:

- Was the test representative of the actual use of the material? The material in a laboratory test is subjected to other circumstances than in the final application. Significant differences can arise between the behaviour of the material in a product application and in the laboratory. This can be caused, amongst other things, by:
 - The production of the test specimens. Has the same method been used, are the thickness and the structure of the laminate the same? Making test specimens with hand lay-up for a structure that has been pultruded will probably lead to underestimation of many properties. In pultrusion, for example, the fibre content and the alignment of the fibres is probably more readily reproducible than in the case of hand lay-up.
 - The applicable norm/standard and/or geometry of the test piece. Depending on the shape of the test piece and any accessories, the results may be better or worse. For example, the width-tailoring or support of a measurement section can have a considerable influence on the end result. Various standards exist for the measurement of the same material property (e.g. compressive strength and shear strength). Each have their particular characteristics.
 - Environmental influences such as temperature and moisture. In the laboratory, these are generally maintained at a particular value (e.g. 23°C and a relative humidity of 50%).
- Calculation and presentation of results: stiffness is generally determined in a particular strain range. In the case of non-UD laminates and shear properties in

particular, stiffness can differ considerably for various strain ranges. In other words, it is important to have an idea as to the shape of the whole stress/strain curve. That is not always presented, however. In addition, an average value is often given in which the spread is sometimes expressed in standard deviations or variation coefficients. Which value would you use for your design?

Reliability: design and statistics

Suppose that a certain property (e.g. strength) is very accurately and reliably known. In addition, the load has a constant value. As a designer, all you have to do is make sure that the strength is marginally higher than the load, to make sure that the product never fails, but is not overdesigned:

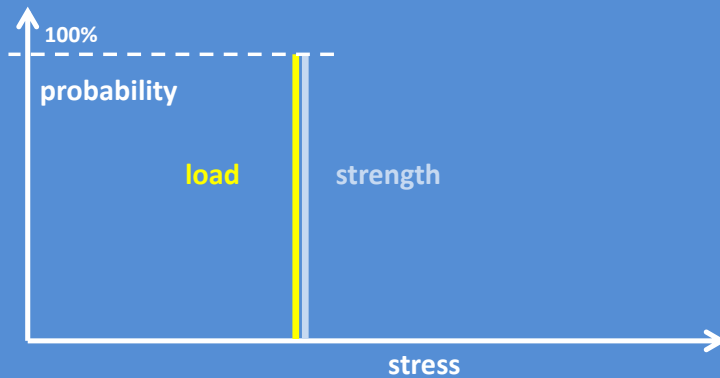

In most cases, however, the product's material properties are subject to variations because of the manufacturing method, tolerances, environmental influences, etc. The loads are also not completely known (e.g. how many cars, trucks, cyclists will use a bridge during its lifetime?).

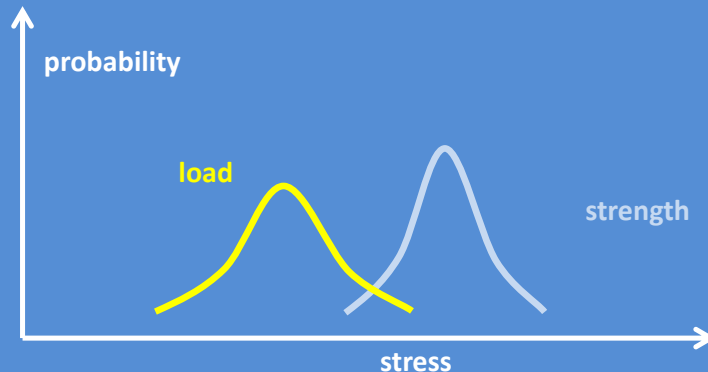

Strength and load can be described as probability distributions. In the above figure, the horizontal axis shows stress, the vertical axis shows the chance of this stress occurring. At the overlap of these probability distributions, failure occurs. Using statistics and diagrams like the above, the reliability of a structure can be calculated.

7 - 4 Sources

- [1] ISO, 'Determination of tensile properties', ISO-527
- [2] ASTM, 'Standard test method for determining the compressive properties of polymer matrix composite laminates using a combined loading compression (CLC) test fixture', ASTM 6641, 2009
- [3] ASTM, 'Standard test method for shear properties of composite materials using the V-notched beam method', ASTM 5379, 2005
- [4] www.wyomingtestfixtures.com (with permission)
- [5] ASTM, 'Standard test method for shear properties of composite materials by V-notched rail shear method', ASTM 7078, 2005
- [6] ASTM, 'Standard test method for short-beam strength of polymer matrix composite materials and their laminates', ASTM 2344, 2000
- [7] ASTM, 'Standard test method for transition temperatures and enthalpies of fusion and crystallization of polymers by differential scanning calorimetry', ASTM 3418, 2008
- [8] ASTM, 'Standard test method for glass transition temperature (DMA T_g) of polymer matrix composites by dynamic mechanic analysis (DMA)', ASTM 7028, 2007

7 - 5 Exercises for this chapter

- 1) Explain why width-tailoring in the testing of composite materials does not always work.
- 2) Name three pros and cons of both an extensometer and a strain gauge.
- 3) Give two reasons for using a multiaxial strain gauge.
- 4) A piece of glass fibre reinforced epoxy composite of 25x25x3 mm is dry weighed (x g), and wet weighed (the piece has been immersed in water with a density of 1 kg/l and is suspended from a weighing scale). The resin is then removed in an incineration furnace. The remaining glass package weighs y g.
 - a. What is the fibre content of this composite?
 - b. The piece shows visible small bubbles (the product was produced by means of hand lay-up). The density of glass and cured resin is 2600 kg/m³ and 1150 kg/m³. What was the air inclusion content?
- 5) Carbon burns (partly) at the temperatures adopted for current fibre content determination. How could you measure the fibre content of a carbon composite?



Language is a standard for mutual understanding. The pride of the Babylonians who intended to build this tower all the way to Heaven was punished with a multitude of different languages - resulting in severe confusion of tongues...

Chapter 8

Standards and Certification

After completing this chapter, you will know the importance of standards and certification. You will be familiar with the role they play from purchasing materials up to and including the use of the end product.

As an engineer, you will be deeply involved in standardisation and certification. Within a company, solutions are often standardised so that work can be done more efficiently. Industry sector organisations, standardisation institutes and certification agencies provide work directives, standards and certificates for whole industrial sectors or fields. The word 'standard' may suggest documents that specify more or less rigid practices and procedures. Nothing is further from the truth, however. Continuous developments in the market and in knowledge, new materials and construction methods necessitate ongoing efforts in the area of standardisation. This also applies to composite materials [1].

8 - 1 A case of trust

Standards offer guidance in the areas of:

- Choice of material
- Design
- Testing
- Sales

The availability of standards and directives generally increases confidence in a product, and thus in the market. When choosing materials for a particular design application, for example, standard solutions are often available which are associated with a certain quality guarantee. Using other materials could require extensive testing. Directives and standards provide information for the designer on aspects he or she must take into consideration and on how calculations should be done. By following standards during the testing of a design, the results are more easily reproducible. They can also be repeated by other laboratories. The ability to demonstrate that you have worked according to a standard and/or have a certificate or some mark of approval – which in turn are based on standardised tests and training courses – helps to cultivate confidence on the part of the customer.

You yourself would perhaps be more inclined to buy a product if it has a KEMA certification or – in the case of a car, for example – if the dealer is a BOVAG member (Dutch association of vehicle traders and workshop owners). However, you should bear the implications of such certificates or standards in mind. An example is the ISO 9000 series. This is a widely-recognised certificate in the world of production companies. An enterprise can obtain this certificate when its processes and administrative procedures are regulated in a particular way and are directed at producing high-quality products and traceability of ingredients. Such an enterprise can still make bad products, however. In principle, an ISO 9000 certificate says nothing at all about the quality of a product. The only assumption you can make is that, thanks to the company's quality policy, errors are less likely to occur and that the causes of any errors that do occur can be more easily traced.

For confidence in a structural material such as a composite, good standards and directives are indispensable. For this reason, standards are widely used. You will find little that is not described in them. There is a standard, for example, for performing Life Cycle Analysis (see Chapter 6). There is even an ISO standard for comparing various kinds of teas [2].

8 - 2 Test standards

As discussed in the preceding chapters, material and structural properties form the basis of a design. Often, identical material properties can be determined in different ways. The procedure for performing a test is documented in a test standard. For composites alone, many thousands of test standards exist. A test standard document specifies within fairly close limits how the material must be prepared, which types of instruments and accessories are permitted, which circumstances are required in the laboratory, which test parameters are of importance and which values they should comply with, how test results should be processed and how they must be reported. When reporting test results, reference can be made to the standard they are based on. That not only saves a considerable amount of writing effort, but also facilitates comparison with material properties obtained with the same or another standard.

8 - 3 Design standards

A design standard or directive describes how to design a product in such a way that it meets requirements. It documents the requirements for strength, stiffness and sustainability and gives methods for verifying product characteristics. Often reference is made to other testing standards.

Design standards are related to a particular way of designing, also referred to as 'design philosophy'. Various design philosophies are possible. The one you choose depends on the application.

In aviation, for example, reliability is defined in terms of a maximum quantity of 'damage' (human lives) per passenger kilometre (the distance multiplied by the number of passengers transported). Here, flight safety and optimisation of the structure are clearly conflicting design aspects. An extremely light-weight structure that fails upon even modest loading is clearly not acceptable. On the other hand, designing an aircraft in such a way that accidents would never happen due to aircraft structural failure may require the use of

more structural materials and thus compromise profitability. The aviation industry therefore adopts 'damage tolerant' designs. That is, one assumes that damage (e.g. fatigue cracks) will occur but – based on insight as to where and how damage occurs – regular inspection intervals and repair methods are prescribed. In this way, light-weight designs can be employed (with the advantage of more passengers per litre fuel) and still be safe.

In bridge design too, a specific reliability is pursued. This reliability is a function of the probability of the occurrence of excessive loads and the probability of the structure not being capable of supporting such loads. In this case, reliability is translated to 'classes', where different requirements would be specified for the reliability of a busy traffic bridge than for a footbridge that is only used for light pedestrian traffic. An interesting requirement for bridges is the maximum deflection. This is based partly on comfort requirements. A bridge that deflects too much may lead to insufficient user confidence, since people are often inclined to think that strength and stiffness are inextricably related. See Chapter 4 for an exercise showing that this is not necessarily the case.

In applications where the probability of human injury upon failure is lower, the philosophy on which a design is based could be different. Costs over the life cycle then play an important role. A wind turbine, for example, is designed for a life cycle of approximately 20 years, with a minimum of maintenance and repairs (safe-life design). Since it is fairly laborious to inspect or to repair a wind turbine regularly, many of its components are built somewhat heavier.

In all cases, a design standard will need to contribute towards creating confidence in a product (the safety image). Design standards are generally formulated in such a way that application of the rules leads to a robust design that could probably be lighter.

8 - 4 Standards development

Various standardisation bodies are involved in making directives for composites. ISO (International Standardisation Organisation) is a worldwide organisation. ASTM (American Society for Testing and Materials), JISC (Japan Industrial Standards Committee), DIN (Deutsches Institut für Normung) and NEN (Dutch Standards) are examples of national standards organisations. These organisations often adopt international standards (of the ISO in particular) or supplement general standards with national annexes that better reflect the practice in the country concerned.

Standards can be quite general in nature and describe, for example, the procedure you must follow in the statistical analysis of a collection of data. There are many sector-related or product-specific standards. There are directives, for example, that describe the design of a wind turbine right down to detail level and prescribe methods that – provided they are correctly applied – lead to a safe design, e.g. the guidelines published by the now merged GL (Germanischer Lloyd) and DNV (Det Norske Veritas). In the construction industry and infrastructure in the Netherlands, the CUR96 recommendation provides directives for the construction of composite bridges, locks and floors, for example.

A directive or standard is generally developed by a committee of experts. A typical committee consists of designers, officials, scientists, representatives of the industry organisation and members of the certifying agency. In this way, a standard is created in which a balance is guaranteed between the interests of the different parties and organisations involved in the subsequent use of the standard. Government authorities, for



Figure 70: For bridges such as this 'Dragonfly' (source: Royal Haskoning DHV) the CUR96 directive [5] offers composite design guidance

example, seek safe structures and standards that are compatible with purchasing policy. Design engineers, on the other hand, need practical design guidelines. It is important that as much current knowledge of structures as possible is incorporated in the standards. Producers and sellers of the structures are interested in a satisfactory balance between their effort in complying with standards and the revenue of their product. Individual producers will find it important to promote their own technology as a standard. The national interests of the participants often play an important role in the development of international standards. The values of safety factors, for example, but also the values of individual influencing factors are partly scientifically determined. To a certain extent, however, it is inevitable that standards are ultimately based on political compromises.

The history of directives shows that directives and standards for composites are strongly linked to specialised fields. If a material finds new application in a certain area of specialisation, it must comply with the same requirements as the traditional materials and structures for that specialisation. Over the past decades, existing design directives and certification requirements have been adapted for composites. Depending on the field of specialisation, such adaptations may take many years to develop. An American directive for ship design, for example, dates back to 1978 [3], while a Dutch directive for civil engineering was released in 2002 [4] and, upon revision, was extended to cover building structures (2013) [5].



Figuur 71: Bicycle/traffic bridge crossing the Dutch highway A27; steel structure with composite deck (source: Fibercore Europe). Standards and guidelines are instrumental in ensuring optimal and safe realisation of such structures in busy traffic nodes. The challenge is to make them applicable to hybrid structures incorporating innovative materials and connections.

8 - 5 Design manuals

As discussed, standards and norms are intended to create confidence in technology and to aid design engineers when using materials that may be new to them. The engineers, however, also need their own judgement in interpreting the various directives. As a rule, standards and norms are impartial, i.e. they do not express any explicit preference for a particular product or tools. They are available at a certain charge from the publisher of the document. Some producers offer design manuals. Such documents may offer extensive and detailed guidance on designing structures using 'their' products. They are often easily obtainable or accessible (e.g. via websites) and sometimes have a clear relationship with formal design directives. An example is a design manual for pultruded profiles [6], based on design standards [7] and [8].

8 - 6 Sources

- [1] Vereniging Kunststof Composiet Nederland, 'Normen en kwaliteit (Standards and quality)', factsheet on design with composites, part 6, via www.vkcn.nl
- [2] http://en.wikipedia.org/wiki/ISO_3103
- [3] Eric Greene Associates, 'Marine Composites', via www.marinecomposites.com
- [4] Ros, M., e.a., CUR96 recommendation, 'Vezelversterkte kunststoffen voor civiele draagconstructies (Fibre reinforced plastics in civil structures)', CUR, 2003
- [5] Tromp, L.T., e.a., CUR96 recommendation, 'Vezelversterkte kunststoffen in bouwkundige en civiele draagconstructies (Fibre reinforced plastics in architectural and civil structures)', revision, SBKCURnet, available as of 2014
- [6] Fiberline Composites A/S, 'Fiberline Design Manual', 2de editie, 2002
- [7] EN13706. Reinforced plastics composites - Specifications for pultruded profiles, first edition, June 2002
- [8] Structural Design of Polymer Composites - EUROCOMP Design Code and Handbook, The European Structural Polymeric Composites Group, John L. Clarke, Sir William Halcrow and Partners Ltd. London, UK (Editors), Published by E & FN Spon, van Chapman & Hall, London, VK, eerste editie 1996

Answers to exercises

Chapter 1

1) *What is the definition of a composite?*

A composite is a material construction that consists of at least two macroscopically identifiable materials that work together to arrive at a better result.

2) *Name three advantages of composites.*

- 1) Weight saving
- 2) Considerable freedom in geometry, choice of materials, choice of process
- 3) Low total maintenance cost

3) *Name three disadvantages of composites.*

- 1) Stiffness and failure behaviour can be inconvenient
- 2) Limited knowledge on behaviour of details and connections
- 3) Often high investment cost

4) *What is the function of fibres in a composite?*

Usually, fibres in a composite determine stiffness and strength to a large extent – A polymer to which oriented fibres are added becomes much stronger and stiffer in fibre direction than perpendicular to fibre direction.

5) *Name three types of fibres.*

- 1) glass fibre
- 2) carbon fibre
- 3) natural (bio-) fibres

6) *What is the function of the polymer in a composite?*

The most important function is that the polymer acts as a 'glue', keeping the fibres together.

7) *What is meant by a ply in a laminate?*

This is a layer of impregnated fibre reinforcement. A stack of plies forms the laminate.

8) *In which two categories – both very relevant for the processing method – are polymers divided?*

- 1) thermoplastics
- 2) thermosets

Chapter 2

1) *Describe at least four processing methods for composites.*

- Spray-up: a mixture of short (chopped) fibres and resin is sprayed onto the mould using a dedicated spray gun.
- Hand lay-up: dry reinforcement layers are put in the mould and impregnated with rollers and brushes.

- Winding: fibre bundles are impregnated and wound around a mandrel.
- Pultrusion: fibre bundles are drawn through a resin bath and, subsequently, through a mould.

2) *What is an autoclave?*

This is a fairly large oven, capable of high temperatures and internal pressure, which can be used to apply the optimal curing conditions to a product.

3) *Explain the difference between a plug and a mould.*

A plug is the 'mould for the mould'; the mould is then used to make the product.

4) *Put these vacuum injection-related terms in the correct order: release agent – mould – peel ply – fibre package – vacuum film – bleeder/breather fabric.*

mould – release agent – fibre package – peel ply – bleeder/breather fabric – vacuum film

Chapter 3

1) *Name three failure mechanisms that can occur with composites, including their possible cause and the measures you can take against the occurrence of these mechanisms.*

Splitting: if many fibres run in a single direction, and the connection transverse to the fibres is not satisfactory, a composite will be susceptible to splitting. Cracks will develop parallel to the fibres, and through the thickness of one or multiple plies. Splitting can occur because of in-plane bending, or a wedge effect of a support or connection. A good remedy is to build up the laminate by alternating plies with different fibre orientations.

Delamination: is similar to splitting, but now the crack develops between two plies in the plane of the laminate. This failure mechanism can easily occur, since the shear stresses between plies can be high and usually the inter-ply interface is not reinforced. A remedy is preventing high shear stresses between plies. If this is not possible, reinforcement can be directed through-the-thickness, for example stitching plies together, or applying 'Z-pinning'.

Buckling: macroscopic- or Euler-buckling is a structural property which can develop regardless of material in long, slender structural elements loaded in compression. The possibility of damage because of buckling should be considered in design. This can be the buckling of fibres, bundles and plies that buckle under load (often in this order). Resistance against macroscopic buckling can be increased by using a stiffer material or structure, or by reducing the free buckling length. This can be done by reducing the size of panels or using (thicker) sandwich layers.

2) *Derive the compliance matrix from the stiffness matrix and/or vice versa by inverting the matrix.*

See chapter.

3) *What is meant by the finite element method?*

In this method, a structure is divided into 'building blocks', each of which has the characteristics of the structural material. This method allows to determine stresses and displacements in a relatively complex structure based on a simple set of material properties.

- 4) Give at least 4 handy rules of thumb for a good laminate structure.
- Use symmetrical laminates
 - Use balanced laminates
 - Avoid stiffness jumps between plies
 - When bonding two laminates, apply the adhesive to plies that deviate at most 45° from the main direction
 - Use quasi-isotropic laminates where possible
- 5) For 55% (volume), a UD ply consists of fibres; the rest is resin. The stiffness of the resing (epoxy) is 4 GPa. The stiffness of the fibres (glass) is 72 GPa. What is the stiffness in the fibre direction of the ply?
- $$E_c = 0.55 \cdot 72 + 0.45 \cdot 4 = 41.4 \text{ GPa}$$

Chapter 4

1 Demonstrate, using the formulas given in this chapter, that the values in the bottom table are realistic.

Relative stiffness

The moment of inertia of a sandwich cross-section is predominantly determined by the skins. In a panel (no core) with width b and thickness t , the moment of inertia is:

$$I_{\text{plaat}} = \frac{1}{12} b t^3$$

For the case in the second column (total thickness $2t$), the moment of inertia can be determined in two ways:

- Subtract the moment of inertia of an element of thickness t from the moment of inertia of an element with thickness $2t$:

$$I_{2t} = \frac{8}{12} b t^3 - \frac{1}{12} b t^3 = 7 \cdot I_{\text{panel}}$$

- Compose the total moment of inertia from the moment of inertia of the elements neutral axis, and the added term according to Steiner's rule (cross-sectional area multiplied with the square of the neutral axis shift):

$$I_{2t} = \frac{2}{12} b \left(\frac{1}{2}t\right)^3 + 2b \frac{1}{2}t \left(\frac{3}{4}t\right)^2 = \frac{1}{6} \frac{1}{8} b t^3 + \frac{9}{16} b t^3 = 7 \cdot I_{\text{panel}}$$

Relative strength

The stress in the skins is given by:

$$\sigma = M \frac{y}{I}$$

The outer fibre distance (distance of outer fibres to neutral axis) y will double, while the moment of inertia becomes 7 times as large. The ratio y/I therefore becomes 3.5 times larger.

2 What has been omitted in calculating the values for the row 'Relative stiffness'?

Shear deformation.

3 Name three advantages and four disadvantages of sandwich materials.

Advantages: Often good combination of stiffness and weight; thermal and acoustic insulation; suitable as anti-buckling element.

Disadvantages: sensitive to delamination of skin and core; connections require additional attention; integration in a product requires additional attention, e.g. degassing in a vacuum-process; shear deformation can be considerable.

4 For a typical pedestrian bridge, two possibilities are considered for the supporting structure: one with two steel girders and another based on a sandwich (glass fibre-reinforced polyester with PVC core). The bridges have identical dimensions: a width (b) of 2 metres, a span (L) of 5 metres and a construction height (h) of 305 mm. The data of the two steel I-sections and of the used sandwich are shown in the figure and table. The deflection of bridges must be smaller than 1/250th of the span.

a. Calculate the maximum load in the steel variant as a result of a load P in the middle of the bridge. Calculate the normal and shear stress in the steel section.

The maximum deflection in a steel profile (disregarding shear deformation) is given by:

$$\delta = \frac{PL^3}{48EI}$$

If this is limited to 1/250th of L , i.e. 20 mm, this means for the total load:

$$P = \frac{48EI}{250L^2} \sim 377 \text{ kN}$$

The normal stress (in longitudinal direction, maximum near the top and bottom area of the flange) follows from:

$$\sigma = \frac{Mz}{I} = \frac{PLh}{8I} \sim 615 \text{ MPa}$$

Whilst the average shear stress (a non-conservative approximation!) is calculated as:

$$\tau = \frac{P}{A} \sim 55 \text{ MPa}$$

b. In which direction do most fibres lie in the skins of the sandwich?

It is advisable to orient most fibres in the direction of the highest stresses. In the flanges of a bridge support beam this is in longitudinal direction. Orienting part of the fibres in other directions, however, is necessary to avoid e.g. splitting.

c. What are the deflection and the stresses in the sandwich variant for this load? What do you notice?

With the formulas from the chapter:

$$\delta = \frac{PL^3}{48D} + \frac{PL}{4AG} \sim 64.4 + 0.77 \text{ mm}$$

This is larger than in the steel option, and the requirement w.r.t. deflection is not met. The reasons are that the skins are less stiff and there is more deformation in the core. Also note, that the stress in the skins is much lower than in the steel beam flanges. Therefore, the bridge is less stiff but stronger at the same time.

Furthermore, the weight is 60% of the steel option (536 kg in steel, 322 kg in composites). The composite option comes with an integrated 'deck', which needs to be installed separately in the steel bridge.

d. Which measures do you propose to reduce the deflection of the sandwich bridge? Which is the most effective?

Increasing the total thickness of the bridge by increasing the core thickness will lead to a stiffer bridge and is most likely the most effective. Another option is to select a stiffer skin material – e.g. based on (expensive) carbon fibres. Instead of a sandwich core, composite shear webs, with fibres in $\pm 45^\circ$ with respect to the main direction of the web (beam longitudinal direction). In this case, the use of pultrusion profiles is not so far away any more.

Chapter 5

1 *List in order of strength: double lap joint – slanting lap joint – a single lap joint – bevelled lap joint*

From weak to strong: single lap joint – bevelled lap joint - double lap joint – slanting lap joint

2 *Name three advantages and three disadvantages of a pin-loaded hole joint in composite materials.*

Advantages: Simplicity, can be taken apart, quality does not highly depend on temperature and humidity at time of connection; suitable to connect different materials; can be relatively easily monitored.

Disadvantages: Fibres are cut, leading to lower strength and potentially large stress concentrations. Delamination can be induced when making the hole. Creep can result in loss of pre-stress.

3 *Name three advantages and three disadvantages of an adhesive joint in composite materials.*

Advantages: Leak-proof, even load introduction, no holes required.

Disadvantages: Quality depends on pre-treatment, poor characteristics in out-of-plane stress situations (peeling), usually not easy to take apart.

4 *A pin-loaded hole joint is sensitive to different failure mechanisms. Give a possible remedy for the failure of a pin-loaded hole joint:*

a. shear fracture

This can be avoided by applying $\pm 45^\circ$ plies next to the pin-hole joint:

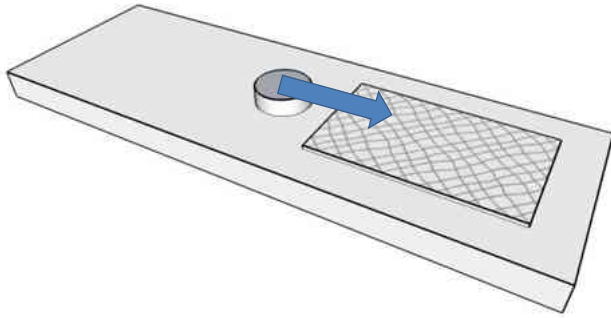

b. tensile fracture

Can be avoided by applying additional UD layers next to the joint, with the fibres in load direction:

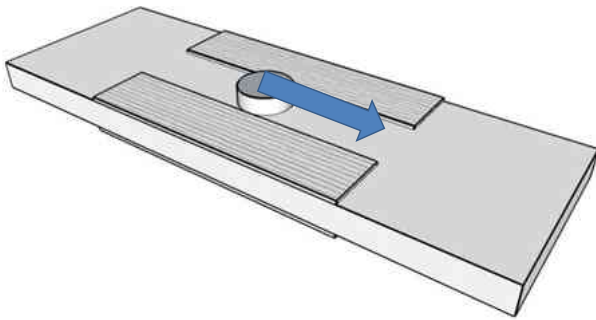

c. splitting

This can be avoided by applying additional layers next to the joint, transverse to the load direction:

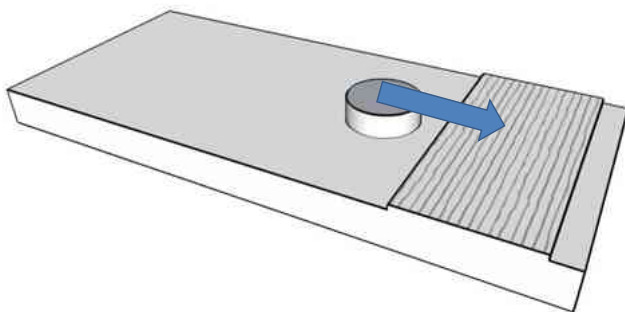

Chapter 7

- 1) Explain why width-tailoring in the testing of composite materials does not always work.

Delamination and axial crack development can effectively render an originally width-tailored specimen to a rectangular specimen. This especially happens in fatigue tests on UD-dominated specimens.

- 2) Name three pros and cons of both an extensometer and a strain gauge.

Extensometer, advantages: reusable, suitable for fatigue, measures average stiffness over larger part of the surface than strain gauge.

Extensometer, disadvantages: relatively expensive, surface measurement, not a local measurement (measures average strain between extensometer contact points)...this can be a disadvantage!

Strain gauge, advantages: cost-efficient, local measurement.

Strain gauge, disadvantages: non-reusable, sensitive to fatigue, measures surface strain only.

3) *Give two reasons for using a multi-axial strain gauge.*

Multi-axial strain gauges are required for measuring shear stress and Poisson's ratio.

4) *A piece of glass fibre reinforced epoxy composite of 25x25x3 mm is dry weighed (x g), and wet weighed (the piece has been immersed in water with a density of 1 kg/l and is suspended from a weighing scale). The resin is then removed in an incineration furnace. The remaining glass package weighs y g.*

a. What is the fibre content of this composite?

The composite volume is $C=(x-z)/1$. After incineration, y g remains. If the density of the fibre is known (e.g. 2600 kg/m³), the volume F can be determined ($y/\text{fibre density}$).

The resulting fibre volume fraction then is: F/C .

b. The piece shows visible small bubbles (the product was produced by means of hand lay-up). The density of glass and cured resin is 2600 kg/m³ and 1150 kg/m³. What was the air inclusion content?

The fibre volume is known (F). The volume of the resin can be determined from $M=x-y$. The inclusion volume then is: $I=C-(F+M)$.

5) *Carbon burns (partly) at the temperatures adopted for current fibre content determination. How could you measure the fibre content of a carbon composite?*

For such materials, the resin can be removed using a strong acid (provided that this does not damage the fibres).

Content and illustrations

In 'composing' this textbook, no attempt was made to document new knowledge, but merely to limit the content to a small part of the extensive and highly interesting existing knowledge, selecting what was deemed indispensable basic knowledge of a 'Hogeschool' engineer (see: VKCN working group Education). We used the expertise and lecture notes of the main author and numerous teachers and industry experts, who gave useful feedback to concept versions of this document. The final text and editing was done by the main author. If anything is unclear, incorrect or incomplete, that is entirely on his account.

This book contains many (original) photos and illustrations, where care was taken to insert references to the source or source of inspiration. To avoid cutting and pasting from existing literature and to have a consistent set of figures, many illustrations were redrawn. This book contains 4 types of pictures and illustrations:

- Pictures from named sources
- Pictures from the main author's collection (no mentioned source)
- Illustrations inspired by existing illustrations ('based on:...')
- Illustrations not based on existing illustrations or very general illustrations (no mentioned source)

The Dutch edition of this book seems to have become widely used in the past years. At least part of the reason for that must be that, having been published under Open Access conditions, it can be downloaded for free or ordered as a hardcopy for an administration fee. The quality of free documentation from the Internet is partly determined by the feedback from the users. Therefore, the author invites all useful feedback for further improved editions to: rogie.nijssen, followed by the 'at'-sign, followed by: inholland.nl. Thanks!

VKCN working group Education

At various ‘universities of applied science’ in the Netherlands, composites are employed. Teachers and team managers who have expertise and interest in the development of composites education have united in the VKCN working group Education, via the ‘Platform Composites’ (which emerged from the educational user group of a national project RAAK-pro ‘Quality Composites’), and coördinated by the research & education group ‘Groot Composiet’ of Hogeschool Inholland.

The main objective is to share and combine expertise with composites education. Bonds with industry are used to inventorise their requirements regarding ‘composite competences’ of our alumni.

In 2012 the platform decided to translate the members’ expertise into this textbook. Contributions and reviews of the book were provided by:

Hogeschool	Contact person
Hogeschool van Amsterdam (Hva)	Maaik Borst
Avans	Dik Overdijk
Fontys	Bart Bastings
Hogeschool van Arnhem en Nijmegen (HAN)	Rens Horn
Haagsche Hogeschool (HHS)	Nico Persoon
Hogeschool Inholland	Rogier Nijssen
Hogeschool Zeeland	Willem Haak
Noordelijke Hogeschool Leeuwarden	Jaap Verhage
Saxion Hogeschool	Paul de Roos
Hogeschool Windesheim	Alexander Jansen and Margie Topp

The following colleagues contributed to the first two Dutch editions (in random order):

Katrin Tazelaar, Joop van den Burg (Bijl Profielen), Colin Leek and Kathy Cannings (Pultrex), René Homan (Nedcam), Antoine Gerritse, Rob van Leeuwen, Koert Dingerdis (Inholland), Edo Kuipers (Tres4), Don van Delft (WMC), Liesbeth Tromp (Royal Haskoning DHV), Ane de Boer (RWS-GPO), Sebastiaan Lindstedt (Bright Composites), Jack Smit (Polux), Roxy Goudsmit (VKCN), Simone Luijendijk and Bertrand van Leersum (ATO) and students Bart van Oploo, Dirk van Viegen, Dave Stet and Jannes de Vries.

The English translation was made possible with help from Rens Horn, Nick den Uijl, and their colleagues at the language center of HAN. Useful feedback and contributions were provided by Marten-Jan de Ruiter and Tjeerd van der Zee (WMC), Bart Bastings and Ernie Frieke (Fontys), Alexander Krimmer (Euros), Maaik Borst (HvA), Jan Peeters (Fibercore Europe), Simon Fidder (VKCN), Vikki Small (TenCate), Martine van der Ent (Euroresins), and Jasper Klarenbeek (CompoWorld). Thanks to their efforts, the potential audience will grow from ca. 20 million Dutch speaking people to 5 billion English speaking people.

The research & education group ‘Groot Composiet’ was initiated at Inholland with the help of the EFRO/Kansen voor West project ‘Open Innovatie Alliantie Groot Composiet’ (Open Innovation Alliance), that ran from 2009 to 2013. This was a collaborative project of various companies and knowledge institutes which shaped numerous innovative composite developments.

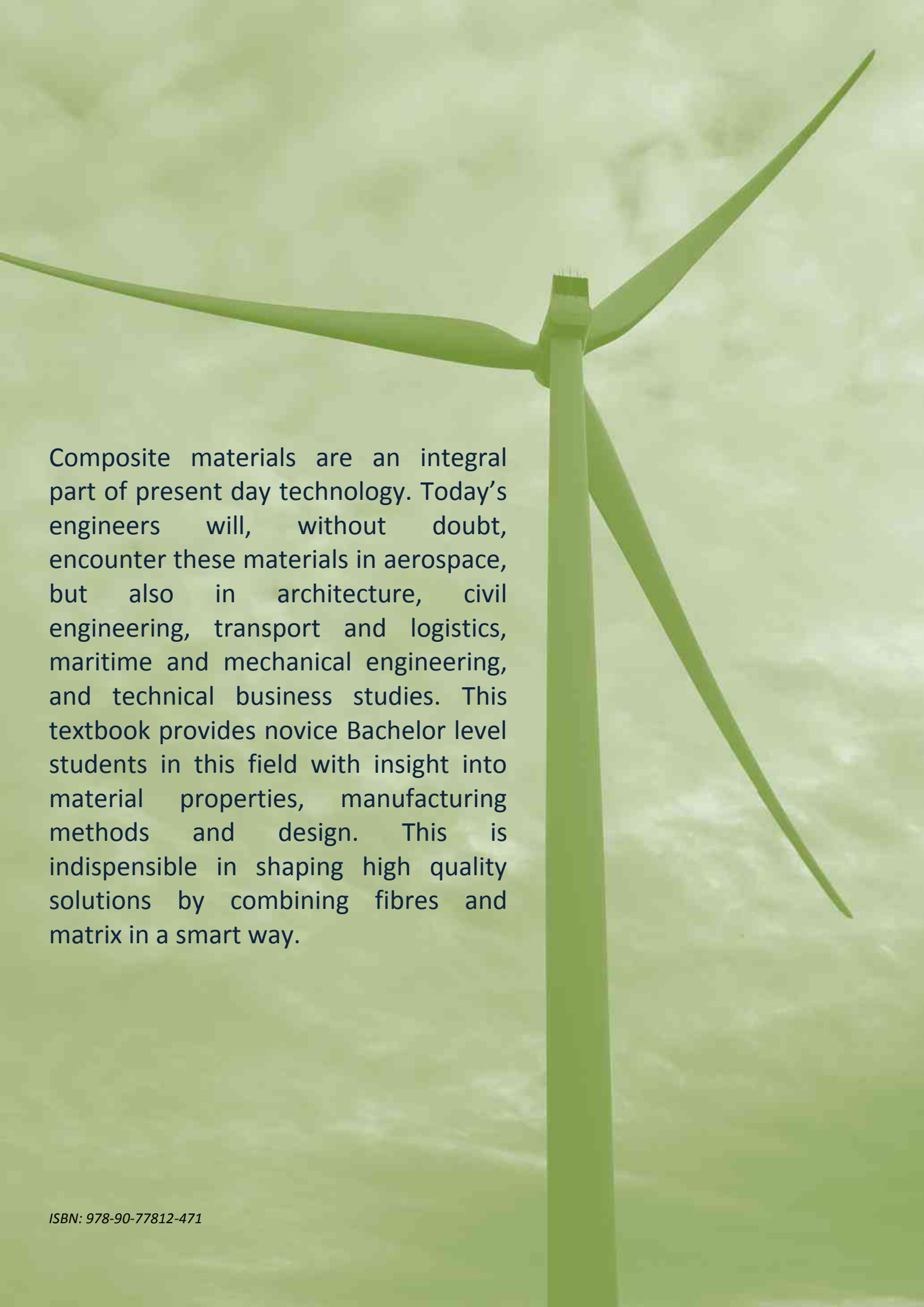
A green-tinted photograph of a wind turbine against a cloudy sky. The turbine is the central focus, with its three blades extending outwards. The sky is filled with soft, white clouds, and the overall color palette is a monochromatic green.

Composite materials are an integral part of present day technology. Today's engineers will, without doubt, encounter these materials in aerospace, but also in architecture, civil engineering, transport and logistics, maritime and mechanical engineering, and technical business studies. This textbook provides novice Bachelor level students in this field with insight into material properties, manufacturing methods and design. This is indispensable in shaping high quality solutions by combining fibres and matrix in a smart way.