

# CYCLISTS' 'AIDS' 1960

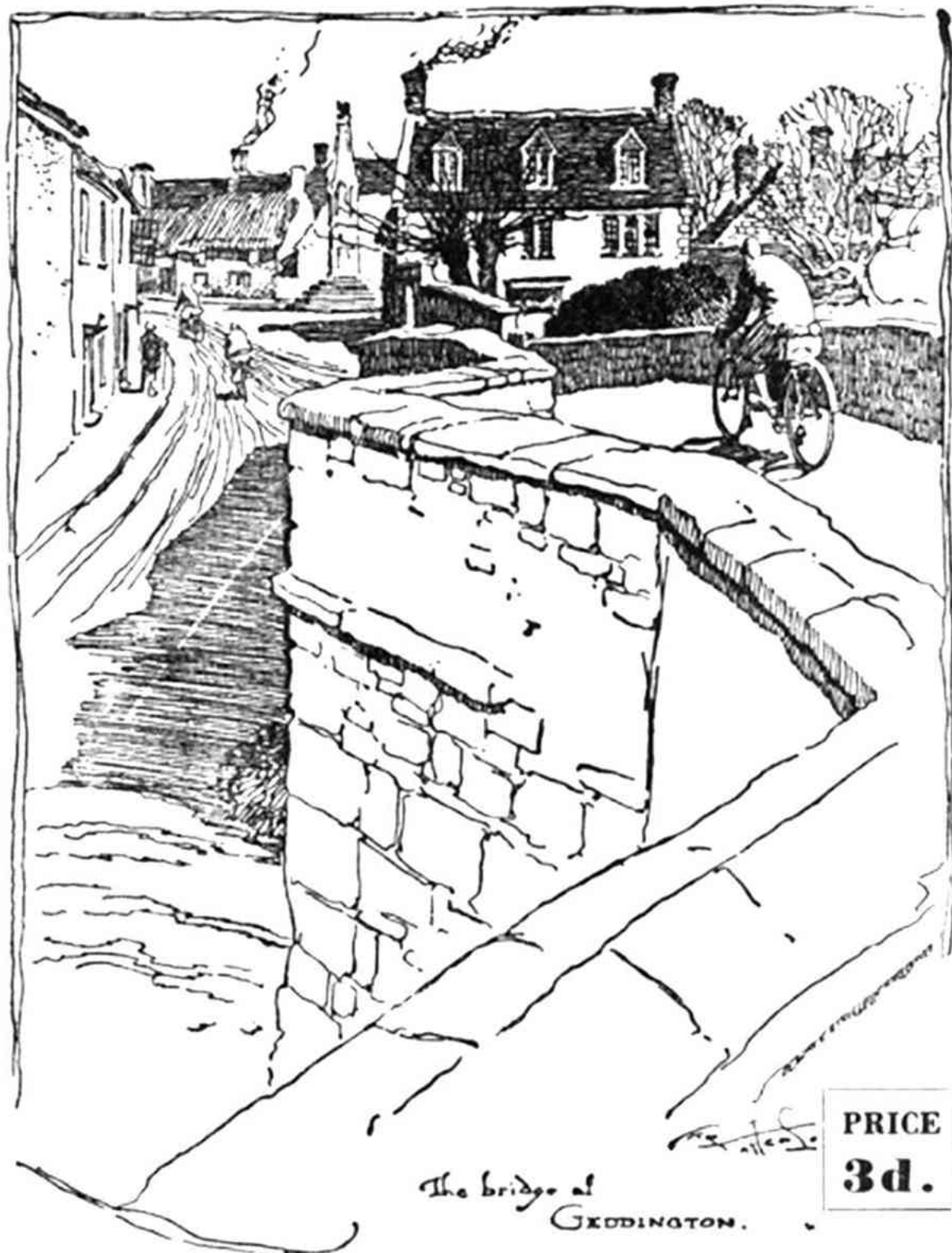

PRICE  
**3d.**

The **HOLDSWORTHY** Co. Ltd., London, S.E.20.

*Any of the items listed may be obtained  
through*

**YOUR LOCAL AGENT: —**

A guide to the latest and best British and Continental equipment for 1960. Our enthusiastic Staff of Club Cyclists maintain a unique connection with the Trade on the Continent combined with an intimate knowledge of the Home Market which ensures that this list remains "up to the minute" year after year. Published in a convenient pocket size so that it may be carried at all times. Turn to the **INDEX ON PAGE 40** for quick reference.

We regret we must state that owing to present conditions **prices are subject to alteration without notice. All prices include any Tax payable.**

## CLOTHING

### ANKLE SOCKS (Elastic Tops—Nylon Spliced)

Nylon Extensible in an attractive fancy pattern. White only. Always a comfortable fit and will not sag. Dry quickly when on tour. One size only ... .. 5/9

**Fausto.** The Continental Pursuit sock with extra length worn by the world's most prominent riders. Fine rib ... .. 3/8

**Rayon Mixture.** Close-fitting ankles ... .. 2/3

### BERETS

Genuine Cyclist's Berets, with 9" close-fitting crown and leather sweat band. All wool, in Wine, Marine, Olive, Nigger, and Black. Three sizes ... .. 6/1



### CAMPIONE RACING CAPS

Genuine Italian pique racing caps available either with or without the word "Campione" (Champion) printed on the front and underside of the small peak so that it reads correctly when the peak is turned up giving a real "Continental" appearance (as illustrated).



White with silky lining for cool riding. Elastic at back for easy fit. One size only ... .. 5/-

Similar cap in White, Blue or Red with two narrow contrasting bands running over the crown ... .. 5/6

## CAPES

**QUELDA.** Holdsworth's Popular Plastic Cape with welded seams and spot welded thumb loops. The material is **really** tough and is nearly untearable. All seams are welded so that there is no stitching to cause leaking or weakness. It is fitted with zip, set diagonally, with tag to prevent tearing. Zip has also cover to stop wet seeping through. **Ventilated** back (welded) to lay the condensation bogey. Special full cut style. In Gold or Matt Black. Size 45", Hem 135". 14 oz. ... 24/9  
**SPECIAL "JUNIOR"**  
Lighter plastic welded, 39", gold only 17/6  
**"STORM CHEETAH"**  
Plastic, Satin finish. Gold or Black:  
42" 18/8; 45" Standard 20/2; Oversize 21/8



## SOU'WESTER

In plastic, waterproof and light, Gold or Black. Size 6 $\frac{1}{4}$ " and 7" ... 4/11

### QUEL-SPATS (As illustrated)

The ideal weather protection. Elastic under knee. Full protection right around leg. Press-stud fastening reinforced with spot welded backing. Plastic under-strap. Gold or Black, pair 9/9  
**"STORM CHEETAH"** Spattees. Over toe and knee, Gold or Black ... 9/9

## QUELDA LEGGINGS

Sturdy leggings with gusset opening, fitted press-studs which are set in welded plastic washers to prevent pulling away. Reinforced over instep. Gold or Black. 30" and 32" ... 20/6 pair

**"STORM CHEETAH"** Leggings.  
Plastic, Satin finish matching cape in Gold or Black ... 12/5  
**"KLEANFEET"**. These handy plastic flaps assist in keeping your legs and feet dry. Elastic loops at the sides slip over mudguard bolts or wingnuts. Gold or Black ... 1/9

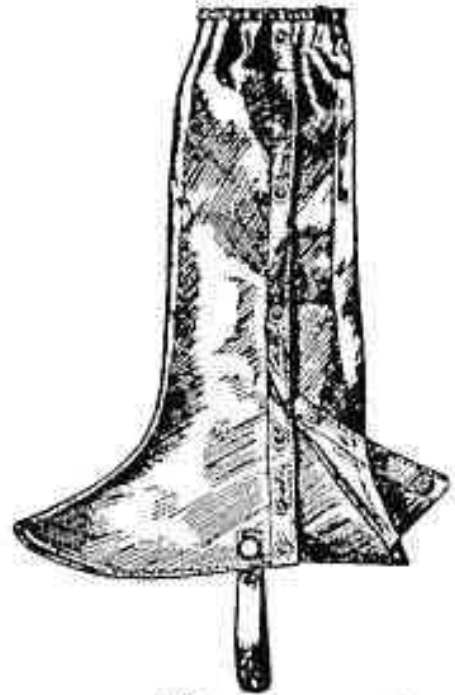

**SADDLE COVER.** Keep the rain from your saddle—one wetting will do more harm than a year's riding. Elastic all round and takes but a moment to fit. In Gold or Black Plastic ... 1/6

### PLASTIC REPAIR OUTFITS

Handy size tube of special solution and transparent patching for repairing small tears in plastic ... 1/3

## CRASH HATS

**EMPIRE CHAMPION.** Shaped to fit well down over the head. Heavy frontal protection, tan leather with cream lining, N.C.U. approved. Three sizes 33/-  
**SIX DAY.** Square section ribs heavily padded (including crossbars) to give complete protection. Black. Three sizes.

27/11

**CASQUE PRIMO** (As illustrated). Deep-crowned Italian crash hat with front and rear protection and padded cross-members. Comfortable, stylish, medium weight. Black only, 54—60 mm. (57 is approximately 6 $\frac{7}{8}$ ") ... 27/11



**CASQUE FAUSTO.** Italian pursuit or massed start crash hat. Light chromed leather over sponge covered cork bars. Folds to fit pocket when away from the "peleton", 5 $\frac{1}{2}$  ozs. ... 26/5

## WORTHY GLOVES

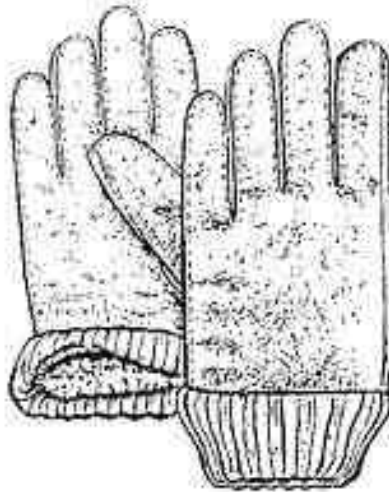

(See left) **HIDE/SHEEPSKIN GLOVES.** Hard wearing fleecy-lined Hide glove with smart knitted woollen wrist and reversed Natural Sheepskin back for extra warmth. With finger and thumb gussets in Hide, back of thumb being Sheepskin ... 25/3

**GAUNTLET.** In guaranteed solid hide. Dark tan, separate forefinger. Gusset at side of forefinger and bag ensures very comfortable fit. Warm, lined throughout, soft gauntlet which effectively prevents the cold creeping up your arm. Sizes: Small, Medium and Large ... 24/3



## NATURAL SHEEPSKIN MITTS

(See right) This full bag mitt, has the long silky-textured fleece turned inside, with reinforced thumb and ample extended cuff which may be turned down ... 24/9

**SUPREME MITTS.** First finger separate. Strap and stud adjustment at wrist for close fit. Beautiful soft tan leather ... 27/3

**KNITTED WRIST MITT.** In strong tan hide, with warm lining ... 19/6  
 First finger separate as above ... 21/6



## GLOVES (continued)

**WORTHY LEATHER PALM** (illustrated)  
Close woven cotton, Black/white marl, with warm backing and ribbed wrist for warmth. Complete palm, front of fingers and side of index finger reinforced by supple Cream leather for hard wear. Smart and handy. Small, Medium and Large ... .. 11/3

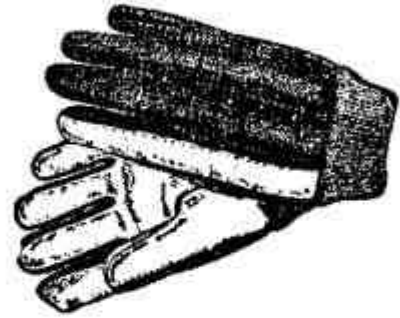

**WORTHY COTTON.** As above, but without leather. Surprisingly warm, ideal for Spring and Autumn wear, takes the nip out of early morning and evening rides, easily stowed into pocket for rest of day 4/11

## JACKETS

### THE "EVEREST"

This popular Jacket has two deep zipped breast pockets and two ample lower pockets set at the correct angle for use when strolling around. There is the usual full cut across the shoulders to give an easy position when riding. Full-length zip and strap-and-buckle adjustment on hips. In a fine Rayon Gabardine with silky surface and lined throughout in "shot-silk" material.

In Black, Green or pleasing Smoke-Grey. Sizes 34"—42" ... .. 52/11  
Large sizes (44", 46") extra.



**LADIES' "EVEREST"**. With flapped lower pockets and elastic at waist for comfortable shaping, 32"—38" 52/11

### THE "SUMMIT"

Similar in appearance to the "Everest" this coat is designed to withstand really cold weather. Between the main body of the Gabardine and the smart shot-silky finish lining, is inserted a heavy insulating and quilted material. Ample carrying space is provided by two welted lower pockets and two at the breast fitted with zips. In Black or Grey. Sizes 34"—42" 65/9  
Large sizes (44"—46") extra.



## PANTALONS de PARIS

Described by "Cycling" as the only 100 per cent. satisfactory cycling trouser. The Pantalons are cut on fairly close lines with a very small "fall-over" at the knee. The wide elastic band can be turned under the material without the discomfort associated with straps and buckles, giving a very neat appearance. The design cuts wind resistance to a minimum and keeps the trousers clear of the chain and back wheel.

**ACRILAN (70%)** the new "wonder" material; light in weight, but hard-wearing, soft and warm. All the latest refinements—two zipped back pockets, zip fly, foam rubber shirt retaining extended elasticated waistband with zip type adjusters. In attractive Bronze/Lovat shade ... .. 74/8

### GREY and BLACK WHIPCORD.

Smart and extremely hard-wearing, whipcord has proved a boon to the hard-riding Clubman. Fitted with double seat, four pockets, an adjustable elastic back, belt loops and brace buttons.

Men's. 28"—40" ... .. 53/11  
Ladies'. With zip fastening at side. Two side pockets, 24"—32' 53/11



### HOPSACK AND TWILL

Small pattern superfine Hopsack material in Durham Green and Mid-brown. Smooth heavy twill in Brown or Blue. Light to wear, these materials are close woven and will keep out the wind. Cut as Whipcord. In Gent's sizes ... .. 49/11

### The latest CONTINENTAL PLUS 1's

In **Silicone Proofed** material with Green and Yellow, Red and Orange or Blue and Yellow minute flecks superimposed on a neat "modern" Black and White tweed. These attractive mixtures have a pleasing and "different" appearance without being over bright, making a welcome change from the more usual plain colours.

Cut closer and shorter than the standard Pantalon the Plus 1's have two buttoned rear inset pockets and a foam-lined shirt retaining extended waist band with elastic adjusters. Gent's only 28"—34" 56/11

## TROUSERS

**JEANS.** The only genuine all-purpose garment suitable for hacking, working or casual wear. Hard-wearing thick cotton drill, black with contrast stitching, zipped hip pockets and fly. Two "stroller" and one ticket pocket in front. Gent's only ... .. 25/10

## RACING JERSEYS & SHORTS

### WOOL ROAD

Close-knit from fine wool. Crew neck fitted with zip, pockets front and rear. Collar and sleeves trimmed to match double chest band.

In National colours: Gt. Britain, France, Italy and Belgium, with 3" bands ... .. 44/6

To special order (minimum 2) 46/6

**WOOL TRACK.** To special order only. Close-fitting Crew neck with zip, collar and sleeves trimmed to match double chest band ... 38/8

**N.B.**—When ordering special **Road or Track** vests, supply sketch, specify width and position of bands, pockets required, etc. More involved designs at extra cost.



**COTTON TRACK.** With single band woven into the heavy cotton knitted base, quarter sleeves and crew neck. White base with Emerald, Royal or Scarlet band. Black with Scarlet, Emerald or Amber band ... .. 14/6

## WORTHY RACING SHORTS

These are supreme and we suggest that you check the "Worthy" label and ensure you obtain the genuine article.

**WOOLLEN with CHAMOIS SEAT.** By far the most popular short on the British market. Genuine fast colour. Warm and hard-wearing.

**Path Pattern.** Inside spanner pocket. 30", 32", 34", 36" ... 28/8

**"Continental" Road Pattern** with seams at sides—so much more comfortable than the usual pattern and which enables the "U" type crutch to be incorporated. The longer legs and chamois insert which have proved so popular over past seasons have been retained. Hip pocket. Sizes: Small, Medium, Large ... .. 37/6

**SILK LUSTRE MATERIAL with CHAMOIS SEAT.** Keeps its shape, fits closely and always looks smart.

**Path Pattern** with "U" type crutch. Outside pocket. Sizes: 30", 32", 34" ... .. 30/9

**Genuine Continental Madison style.** Reinforced back that will not pull away. After many attempts to obtain the right article we can positively recommend these ... .. 39/6

**HEAVY GRADE COTTON.** Sizes 32" and 34" only.  
With Chamois Seat ... 15/11 ... With Cotton Double Seat ... 11/3



## WORTHY SHORTS

### LIGHTWEIGHT TERYLENE/WORSTED

A beautiful short in tasteful Grey 55 per cent. Terylene/45 per cent. wool mixture of good weight. Cut on close "Continental" lines, fits snugly at waist with zip type adjusters, double button and extended band. Two side pockets, two inset rear with neat buttoned flaps. Shorter legs, discreetly cut, allow full movement without gaping. Dirt-resistant and non-creasing, this material is so hard wearing no double patch is fitted. As smart off the bike as when riding, ideal for Continental holidays ... .. 59/11



**LADIES'** with side zip and double-buttoned waistband, two pockets and blouse retaining "shirt grip". Same colour as Gent's 59/11

**70% ACRILAN.** In modern ALL-ZIP style. Zip fly, two zipped rear pockets (inset), Zip type adjusters to the extended waistband which bears a foam rubber shirt retainer. These Shorts are not cut quite as closely as the Terylene Shorts but have slightly shorter legs than standard. A further point which will be specially appreciated by Continental Tourists, is that one of the hip-pockets is large enough to take a passport or full-sized wallet. In a pleasing Bronze/Lovat shade these shorts are really smart on or off the cycle (no double seat necessary) and will give comfort and hard wear ... .. 52/11



**WHIPCORD.** The Original Whipcord Short which year by year has increased sales—proved by the test of time to give the longest wear.

Two side and two flapped hip pockets. Correctly placed large double seat. Extended waistband with adjusters. You will find that these shorts have just the amount of strength to wear well whilst not being too heavy for summer use. In Rich Brown, Grey and Black. Gent's 28"—40". Ladies' (side zip, no hip pocket) 24"—32" ... .. 39/11

**VELVET CORD** super quality genuine Fustian. Soft and hard wearing. Double seat, two side and one hip pocket, full cut, with good rise at back. Rich Brown shade. Gent's 28"—38". Ladies' (side zip, no hip pocket) 24"—32" ... .. 44/11

**POPULAR.** Lightweight Black Twill. Quite hardwearing. In usual "Worthy" cut for comfort. Gent's only. Sizes 28"—34"

19/11

## WORTHY STOCKINGS

**The QUADRILLE** (as illustrated). Continental pattern diamond hose, all-wool with a bold, clear-cut design and elastic tops. Navy with Red/Blue diamonds, Grey with Black/White, Green with Red/Yellow and Fawn with Green/Red diamonds. Good value, sizes 9"—11½" ... .. 11/6

**MEDICI.** In heavy knit "stretch" Nylon patterned similar to Richelieu. Crisp White only. Will wear for ever and wash and dry with the minimum of trouble. One size 7/11



**RICHELIEU.** The original French style stocking introduced by Holdsworth to the English market. To ensure that you obtain the heavy hard wearing stocking, fancy knit to the toe, in strong natural cotton, look for the WORTHY mark on the foot. Definitely the hardest wearing sock available, this practical garment is very smart, the open knit following the line of the calf closely. Elastic at top, Nylon spliced.

White, sizes 9"—11½" ... .. 6/6  
 Blue-Grey or Fawn, sizes 10"—11½" ... 7/6

**DIAMOND PATTERNED.** Another attractive stocking with elastic top, Nylon reinforced at heel and toe. Pleasing overcheck (as illustrated) Diamonds in combinations of Green and Grey, Maroon and Brown, Double Blue, Grey and Dark Grey, all overchecked in contrasting colours. Moderate blended shades that please all. Sizes: 10"—11½" 7/11

**PLAIN WOOL.** In fine soft lightweight wool with elastic top. Black, Saxe-Blue, Sedge Green, Wine—not too thick for your racing shoes—ideal for training. Sizes 10"—11½" in half sizes ... .. 9/2

With **TURNOVER TOPS** in heavier wool for winter riding in Dark Fawn, Lovat, Bottle Green, Saxe-Blue and Maroon.  
 Sizes 9"—11½" ... 9/-



## CRODONI RACING SHOES

Italian Racing Shoes "Il Crodoni" are the latest Craftsman shoes to be imported into Britain. Styled in the inimitable Italian fashion, the designs are carried out with the best materials by specialist workpeople in that cradle of Italian fashion—Milan.

We are happy to be permitted to introduce to the discerning British Rider the following two models:—

**"VELOCE"**. With its sweeping lines and slender waist, perforated upper and pliable sole, supported at the in-step by a light steel support, will appeal to all riders who are seeking the lightest and coolest of shoes. Lacing down to within an inch of the toe and cut well up the front, the ankle is neatly trimmed in White.

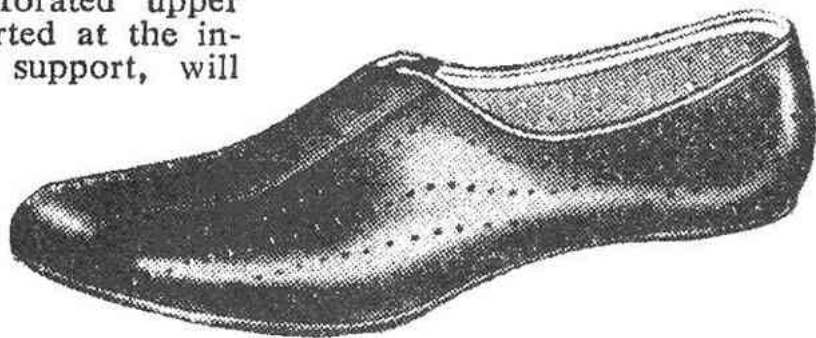

Designed as a purely racing shoe (*not suitable for Club "Football" or Cyclo-cross*) the light sole carries no heel ... .. 59/6

**"GIRO"**. A Road Shoe with the latest ideas of comfort. Well spaced larger perforations in the upper are combined in the Continental fashion, with eight holes in the sole. These latter holes serve a double purpose; in hot weather they keep the feet ideally cool, whilst in rain, when normal shoes become "waterlogged", they enable excess water to run

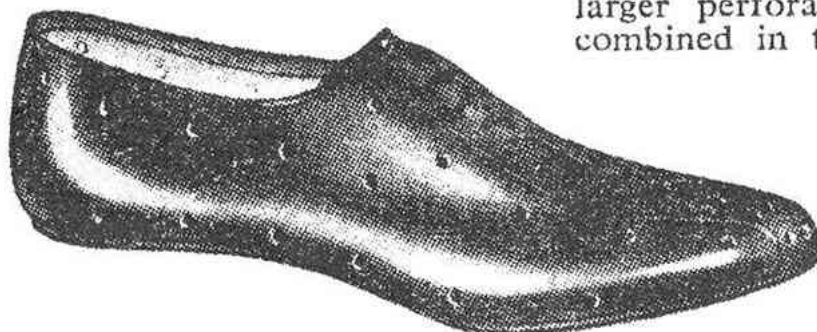

out and avoid the annoying squelch of a waterfilled shoe. The sturdy sole of the "Giro" with its four-point steel support eliminates foot fatigue over the longer distances ... .. 71/9

## WORTHY SHOES

**NEW ROUGHSTUFF.** The latest design of the original "off the track" shoe. The uppers are made from special "TOUGHIDE" leather with a plain toe and webbed tongue to keep out wet. Solid bend sole with narrow sewn welt. Stiffened back. Finished in Scotch grain. Dark Tan. Approved by the Roughstuff Fellowship. Sizes 6—11½ (12 extra) 57/9

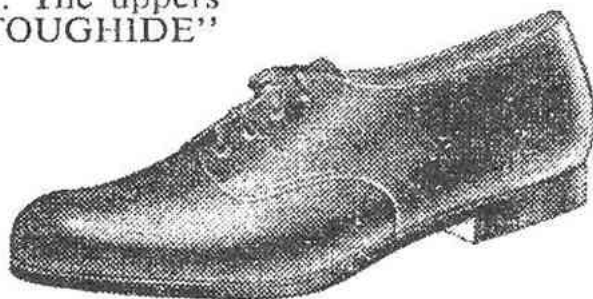

## WORTHY SHOES (continued)

**ROUTIER.** Built on a French last the curved back ensures a close fit throughout the whole life of the shoe, never getting the down-trodden look. The semi-stiffened toe keeps the shape at the front and relieves the toe of pressure from the toe-clip.



Made from specially selected soft box calf, smartness is enhanced by the popular triangular eyelets and white leather trimming. Sizes 5"—11½" (12" extra) ... .. 46/9

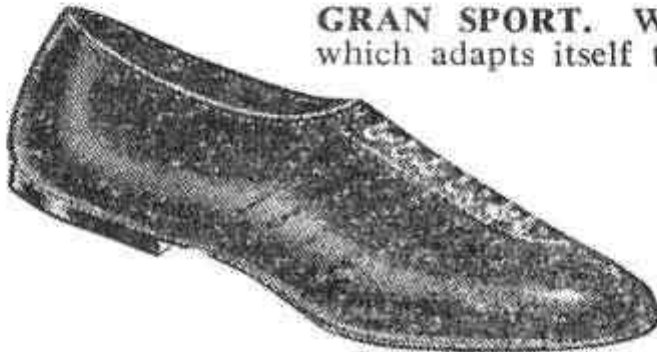

**GRAN SPORT.** With the popular "soft toe" which adapts itself to the shape of the foot. The fully chromed soft black box upper is reinforced at the ball of the foot with four rows of stitching converging into the front strapping preventing "spreading" and ensuring a close fit during the entire lifetime of the shoe.

The soft stiffening at the back of the heel provides a good grip. Good sole carried right through to heel which is of "V" formation. Modern All-black finish. Sizes 3—11½ (12 extra) ... .. 39/11

**RECORD.** These shoes are such outstanding value that they have been widely copied. Compare these points in a genuine "RECORD". Black creamed leather trimmed around top and down front opening with red leather (not plastic, which has a tendency to split). Leather insole (not composition) which enables a satisfactory repair to be made when necessary.

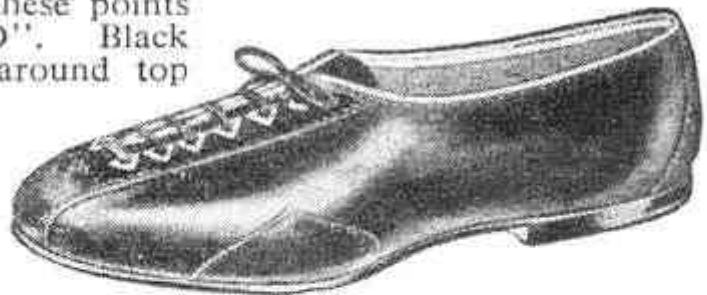

Full light heel. Triangular eyelets. You can be sure of a Genuine Record shoe by the "Worthy" brand under the instep. Sizes 2—11½ (12 extra) ... .. 37/11

**RENOWN.** Latest of the "Worthy" range. A hard-wearing, all purpose shoe at a popular price. Of first-class appearance, the soft creamed Black upper is set off with Grey leather trimming at the ankle. Very small lace holes in the front strapping which runs down to the toe, and a small pedal patch, add neatness to a sturdy shoe. Sizes 5—11½ only ... .. 32/6



## REG HARRIS SHOES

### SUMMER SPRINT (Illustrated).

Light and supple, drilled for coolness. Rolled edge, sewn inside to prevent chafing. Stiffened at instep ... .. 49/11

**WINTER SPRINT.** Similar but without holes in the upper 49/11

**ROAD.** One-piece sole with horseshoe heel, distinctive joined front ... .. 49/11

**FALLOWFIELD.** Fitted with "breather" eyelets at instep and wide strap patches on both sides to give support ... .. 39/11



### EILEEN SHERIDAN

This rider's design for a smart but sturdy ladies' shoe. In soft black calf. Sizes 2—7 only ... .. 47/6

## SHOE LACES AND PLATES

The correct length lace for cycling shoes, difficult to obtain at shoe repairers, 30" ... .. 4d. pair

**ARCHAMBAUD** (illustrated). Alloy blocks, which minimise pedal plate wear, are steel rivetted to a steel plate to form a deep slot. The steel plate will not crack and spreads the thrust over a large area 3/9

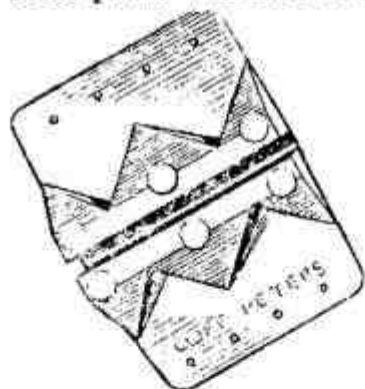

**CAMPIONATO.** Bronze plate with deep slot ... .. 3/6

**PETERS LEATHER** with deep slot in alloy strip set in leather, easy fitting, silent tread ... .. 3/-

**PETERS** light dural, very strong, will stand up to bending and blend into sole of shoe ... .. 1/11

**LEWIS.** Extruded alloy plate, with deep pedal slot and groove for fixing pins 1/11

**KEN RUSSELL.** Rubber, single slot 2/-

## WORTHY SWEATERS AND JERSEYS

**ROUBAIX.** Made from a special close-knit all-wool material, which can only be obtained abroad. Light in weight it is close enough to keep out any wind. A flat "cheval" collar finished in heavy woollen rib to match the vertical bands from shoulder to waist, give a most distinctive appearance, looking equally attractive for cycling or for evening wear with a pair of slacks. This sweater will retain its shape and smartness for longer than most. In two shades, Medium Grey and Dark Lovat. Sizes medium and large ... .. 55/3





## "PICK" SWEATERS made exclusively for Cyclists

**T.D.F. SWEATERS.** A fine ribbed, close knit, medium weight pull-over with close-fitting crew neck and waist-band in a hard-wearing wool and cotton mixture, which will retain its shape and, being of good length, not ride up. Slate Blue, Maroon, Fawn and Bottle Green. Short Sleeves only ... .. 17/6  
**FAIRISLE** band round chest and across top of sleeves, make this Black jersey (similar to T.D.F. above) distinctive and smart 27/-  
**"CONTINENTAL"**. Small shawl collar, long sleeves and smart wide band in contrasting colours across chest. In Tobacco Brown, Bottle Green and Paton Blue. Medium 27/8 Large 31/8



**LE PARIS.** Although illustrated, we feel that no sketch can do justice to the smartness and quality of this British knitted sweater. The stitch used ensures that the garment will keep its shape and not sag. This pure wool garment has a full length zip and the distinctive flat collar enables it to be worn with or without a jacket.

The collar, cuffs and wrists are trimmed with neat contrasting bands.

Latest colours: Saxe-blue, Crimson, Lovat and Bottle Green or Black.

Sizes: 36", 38", 40" 75/-

Larger sizes extra (42"80/3etc.)

**LE PARIS TRAINING LEGS.** In either Black or Crimson. Can be worn separately or as a woollen track suit with a similarly coloured Le Paris Sweater. The same distinctive stitch as above ensures a close, flattering, fit in true Continental style. Pure soft wool and circular stitched chamois seat for comfort. Zips at ankles allow for easy removal without stretching. Ideal for training or warming-up periods and riding down to road events. Medium and large ... .. 67/6

**WOOLLEN LEG WARMERS.** Worn on the coldest morning, will keep the knees and ankles working smoothly. Heavy ribbed wool coming well up the thighs, strap under instep. Black only 24/11

**WOOLLEN ARM WARMERS.** A very handy little item that should be part of every racing man's wardrobe. Saves the expense of a long sleeve jersey and can be removed should the arms get too warm. Heavy wool ribbed at top and wrist. Black only ... 10/6



## TRACK SUITS

These practical garments have proved so popular among cyclists for riding down to road events as well as for training and 'between events' wear, that we have designed a special 'cyclist's cut'. The legs, shaped to fit closely, have long zips at the ankles to keep clear of the chain and two side pockets. The top fits closer than Athletic suits to cut wind resistance. Two styles.

The latest "**MAESTRO**". Smart black silky-finish material with fleecy lining. Top has full open-end zip and pocket set at an angle with zip. Trousers 10" zip at ankles coming well up calf; two side pockets. Cuffs, collar and ankles in ribbed wool with attractive Red and White stripes ... .. 69/11

The "**TRAINING SUIT**" with flat collar, full open-end zip, and breast pocket with buttoned flap and yoke in contrasting colour. These suits are Black with Amber contrasts (double seat) ... .. 66/9

"**WORTHY**" Track Suit (as illustrated opposite). Ample cut with double front. Zips at ankles and neck, elastic at waist and wrists. Hip pocket. Wind-resisting fleecy-backed material in Black, Maroon, Royal Blue. Three sizes ... .. 54/6

"**POPULAR**". An inexpensive track suit in warm, fleecy-lined material. Crew neck style with full shoulder cut for easy movement. Pocket in trousers with elastic at waist and ankles. Available in Black, Navy, Cherry or Steel Blue. Medium size only 42/6



## TRACK MITTS



**CRODONI.** The latest design of track mitt to be produced by this famous firm who make for the top flight Italian professional riders. Made of extremely supple reversed chamois kid, the stepped fingers are neatly finished at the edges for comfort and the reinforcement patch is shaped to the palm. An unusual crocheted back is of very "open" pattern for maximum coolness but, made in strong thread, maintains its shape and, assisted by the adjustable wrist strap, is always a good fit. The thumb back is similar in design and without doubt these are the best mitts ever made by **Crodoni** ... .. 29/6

**ITALIA.** Introduced four years ago, this glove which proved most popular, now has an improved appearance being of Soft Rich Tan leather institched for greater comfort and smartness. Back of hands and thumbs are Italian hand-crocheted open-work giving a close fit and retaining its shape. Reinforced palms, sized half fingers and press stud fastening at wrist in six sizes 0-5 ... .. 26/6

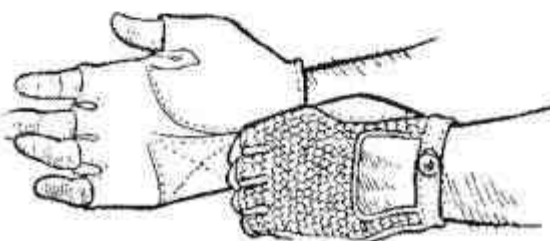

**WHITE ITALIA.** In soft White leather with hand-crocheted back in Italian styling for cool close fit. Institched for comfort, smartly stitched palm reinforcement, sized half fingers and press stud fastening at wrist. Available in six sizes 0-5 ... .. 21/11

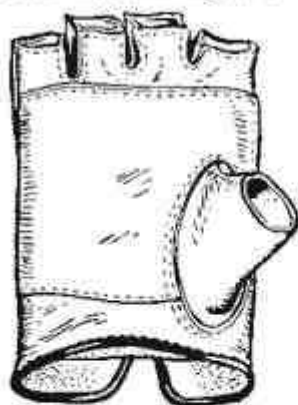

**CREAM HIDE.** For hard wear. Half fingers stepped in sizes. Fully perforated backs with "Butterfly" reinforcement at thumb to take all wear on brake or bend. Sizes 7-10½ ... .. 18/3

**BLACK and WHITE.** Soft White leather with Black reinforcements on palms and Black piping. Very smart and light. Stepped fingers and perforations on backs. Sizes 7-10½ ... .. 15/3

**MORDANT.** Unbeatable value in soft Light Fawn leather. Reinforced palm ... .. 9/11

## SUN SPECS

**NUPROSAL** (illustrated). Modern deep Crookes' tinted lenses, stops sun and grit 10/6  
**CLIP ON.** For spectacled riders. With round lenses 7/8  
**BUSH GLASSES.** Extra large round tinted Crookes' lenses in Gilt frame ... .. 4/6



## ACCESSORIES and SUNDRIES

### "WORTHY" BAGS

**"EVERYMAN"**. Made from special composition, looks like leather, wears like leather. Waterproof. Keeps shape. Two side pockets, strap fastening. Map pocket on top, turn-buckle fastening. Size of Bag: 12½" x 7½" x 8/5".  
As illustrated ... .. 48/6



**CAPE ROLL**. Of heavy grade waterproof material reinforced with leather. 18" straps allow it to be fixed vertically or across the saddle, the roll and tool pocket remain fixed when cape is removed. Pocket 2½" x 1" and 6" deep holds all normal repair outfits easily ... .. 7/6

### PANNIER BAGS

**DEVONIA**. Pannier set consisting of two bags, each 11½" x 10½" x 4". Two large rear pockets with hooded tops. Made in heavy grade leatherette. Piped edges, leather reinforcements to sides. Straps to flaps. Fitted with Quill quick release fittings 43/11 pr.

**HIGHLANDER**. Made from heavy duty black duck material. Long fully chromed straps and chafing protections. Size overall, 12" x 11" x 5". Pockets 8" x 4½" x 1½" (will take maps, touring handbooks, etc.) fitted with hooded tops. Stout carrying handle on top of each bag. Fitted with Quill Quick Release fittings ... 65/8

**HANDIBAGS**. Strong 5 thou' Plastic to fit inside Panniers 3/6

### SHOULDER BAGS

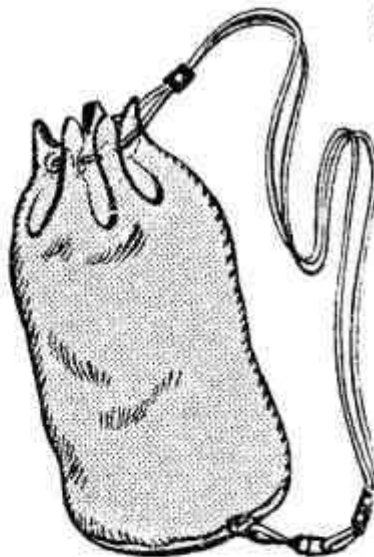

**"SACCO"** (illustrated)

Continental-type Kit Bag. Made in heavy-weight waterproof material with strong double cord fitted through brass eyelets to leather tag by spring clip. Red, Blue or Green plain colours or various smart patterns. Handy size ... .. 9/11

Larger size in Red, Blue or Green only 12/9

**MUSETTE**. Made from rubber-lined material with wide shoulder strap. 14" wide, 10" deep. Red, Green, Blue, Black or Yellow

5/4



## PANNIER BAG CARRIERS

The **QUILL**. Light, but strongly made from best quality tubing. Platform 16" x 5", enamelled jet black with cad plated adjustable clips. There are no sharp corners on a "Quill" carrier to damage your bags ... .. 17/6

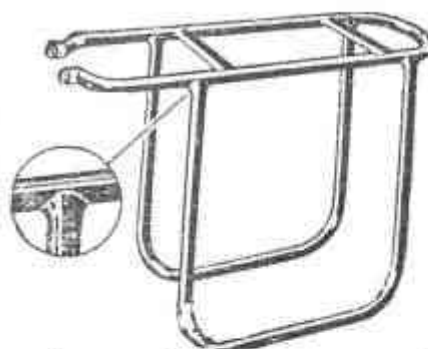

**"CONTINENTAL"**. Light triangular support from platform to mud-guard eyebolt, on drop-out. No clips to chip enamel, top support from brake pivot bolt, will take Release fittings, finished in Silver 10/6  
**FRONT**. Similar, bolts over pivot bolt and hub spindle ... 12/6

**QUICK RELEASE** fitted with rivets to the back of your pannier bags allows the bags to be removed easily. Strong hooks clip over the top of pannier frame and are held firm by a sprung hook at the bottom ... .. 6/11

## BAG SUPPORTS

**BROOKS**. Rigid all-chrome support. Detached by wing nut 5/9

**LLOYDS**. The "Spring-on" support, made in two seat stay sizes.  $\frac{1}{2}$ " or  $\frac{3}{8}$ ". Black ... 5/7. Polished Alloy ... 6/7

**HIGHWAY**. Tubular support with 8" square platform held by rigid arm to a clamp, fitting on seat tube. Black 9/9 Silver 10/9

**KARRIMOR**. Standard uplift. Quick release. Chrome plated 5/6

**KARRIMOR**. Tourist uplift. Quick release. Chrome plated 8/9

## BELLS

**LA CLAIRETTE**. Spring ring bell. Polished alloy ... 2/- each  
 Also highly polished Red, Blue, Gold, Green ... 2/3 each

**CLUBMAN**. Clamps under expander bolt and fits at side of the stem. Single "ping" type. Polished alloy ... 1/10

Also highly polished anodised Red, Blue, Green, Gold ... 2/-

**VICTREE**. Super "Sonnice", Coil spring striker. Polished and coloured ... .. 1/11



## BOTTLES

**ALLEZ!** Polythene. Corrugated sides for easy handling. Ideal for "handing up" will stand a lot of knocking about.

White, Red or Blue ... .. 2/6

**SIMPLEX**. Ice Blue plastic bottle with flat cap. Fits all standard cages 3/11

**HIP FLASK**. Natural colour, weighs only 1 oz., holds  $\frac{1}{4}$  pint ... .. 2/-

**CORKS** with alloy cap ... 6d. each

**DRINKING TUBES**. Polythene 4d. each



## BOTTLE CAGES

**CAMPIONE WIRE CAGE.** Heavy gauge chrome-plated universal fitting Single cage. Can be fitted to either H/bar or D/tube by neat clips supplied. Sprung to allow easy bottle removal and fitted with smart two-colour badge ... .. 8/6

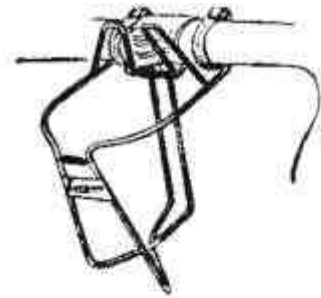

**ALLEZ CHROME** in lighter gauge.

Double 7/6 Single. D/Tube or H/bar 4/6

**PETERS WIRE.** Heavy gauge chrome-plated single for handlebar and down tube, both with bottle lead-in for easy use ... 7/6

## BRACKET FITTINGS

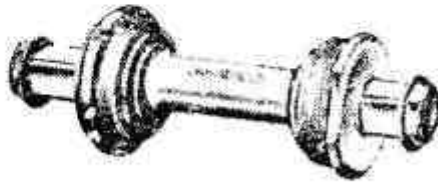

**CAMPAGNOLO.** Cotterless axle suitable for the new chainset complete with fixing bolts and two cups. ROAD for double set 41/6

**CAMPAGNOLO.** Standard sets for use with cotters. Usual high finish with hard chrome bearings ROAD for use with double set PATH for single chain ring. Complete set ... .. 39/6

**STRONGLIGHT** Cotterless No. 97 for 49D and 57 chainsets. 97/32C for single ring on 49D. 97/32RN for double 49D and 57 35/-

**STRONGLIGHT** Standard No. 34 for use with cotters. State axle length. 125 mm. for single and 132 mm. for double sets ... 18/9

**GNUTTI** Cotterless set for double only, complete with key ... 14/3

**B.W. "Featherweight".** Continental cups and L/ring ... 6/3

**B.W.** Hollow racing axles for single or double ... 6/8

**CHATER-LEA** Axles.  $\frac{1}{4}$ " balls (No. 1615),  $\frac{5}{16}$ " balls (No. 1007) 4/6 For double c/sets.  $\frac{1}{4}$ " balls (No. 1615).  $\frac{5}{16}$ " balls (No. 1240/1) 5/- ea.

**CHATER-LEA** Cups. Fixed or adjustable. Chrome ... 3/3 ea.

**CHATER-LEA** Locking Rings ... .. 1/10 ea.

## BRAKES (Spares stocked for all the following)

**MAFAC "RACER".** A most efficient brake Using a centre-pull cantilever action, the arms, independently sprung, pivot on bronze bushes, against a central movable pivot, enabling the blocks to follow a buckled wheel. Giving positive fingertip control. Fitted with hooded lever and cable adjusters ... 62/6

**"CRITERIUM".** Same action as above with brazed-on fork pegs to take pivot fittings. Hooded lever and adjusters ... .. 51/-

**CRITERIUM TANDEM.** Built similar to the above but with longer and stronger arms to give tremendous leverage to the longer blocks and shoes employed. Long rear cable, etc. ... .. 61/6

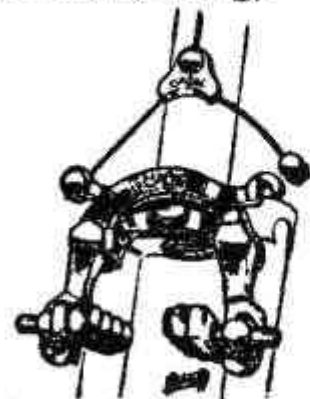

## BRAKES (continued)

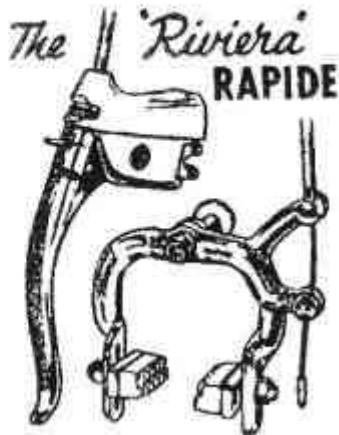

**G.B. "RIVIERA RAPIDE" R.R.** A shallow stirrup brake with Nylon bushes and spring bosses. The Superhood lever is fitted with Rapide Q/release which allows instant wheel removal and resets automatically when next braking ... 42/- pr.  
**"SPORT MARK 3"**. A further development of this well known model. Now has a smart new lever with embossed 'motif'. Re-designed to give maximum braking efficiency, lever is finger-grooved for non-slip grip ... 38/- pr.  
 With Rubber Half-hoods ... 43/6 pr.

**"COUREUR PLUS"**. All Nylon bushed, quick-release, with A standard or B deeper stirrup both with Superhood Plus lever 42/-  
**Anodised** stirrup and lever, either Red or Blue ... 45/-  
**"Grandtour"** Nylon pivot bush, quick-release, extra depth for touring machines and **Touring** lever ... 38/6  
 Any of the above with extra length cable for Tandem 2/- extra

**WEINMANN VAINQUEUR 999** (illustrated).

The highly finished centre-pull brake now fitted with quick-release. The brake arms operate with a compensating cantilever action through Nylon bearings. With polished hooded levers and white lever hood rubbers.

65/-  
**Anodised Red, Blue or Silver as above** 69/-  
 With lever hoods but less quick-release 61/6  
**Anodised Red, Blue or Silver** ... 65/-  
**No. 730/730.** Side-pull with Hooded Levers.  
**No. 500/730.** With Shallow Front Stirrup.  
 Both with efficient quick-release ... 41/9 pr.  
**Anodised** Stirrups and Levers, matching cables. Red, Blue or Silver.  
**No. 730/730, 500/730** ... 45/- pr.  
**No. 890/890.** Deeper stirrups, non-quick release. Racing levers ... 38/- pr.  
**No. 730/810.** Tourist model, short-reach levers ... 33/- pr.

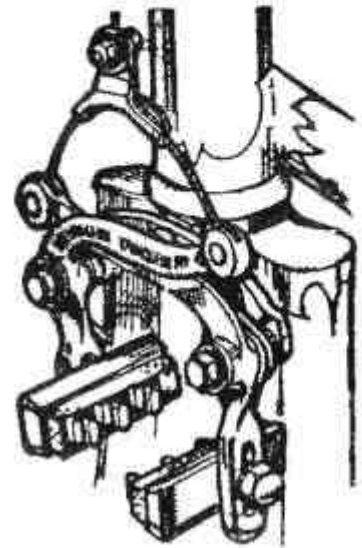

## BRAKE LEVERS



<b>MAFAC</b> (illustrated) Hood and adjusters	13/3 each
<b>MAFAC.</b> Lever only	9/6 ..
<b>WEINMANN</b> 1 1/8" clip. Large Hood	7/6 ..
<b>WEINMANN</b> "Tourist" (short reach, No. 136)	6/- ..
<b>G.B.</b> "Superhood Rapide" (quick-release)	12/6 ..
<b>G.B.</b> "Superhood Plus"	10/6 ..
<b>G.B.</b> "Arret" finger grooved	8/6 ..
<b>G.B.</b> "Touring"	7/6 ..

## BRAKE BLOCKS

<b>MAFAC.</b> Black only 9d. pair. Complete with shoes ...	2/9	pair
<b>WEINMANN STUDDED.</b> Usual Swiss value. Red or Grey	10d.	..
Complete with shoes, nuts and bolts ... ..	2/3	..
<b>SPHINX.</b> Hard-wearing, will not harm light rims ...	9d.	..
<b>G.B.</b> Standard (269) Coureur (282). Hard	8d.	pair
Soft	9d.	..
<b>G.B.</b> Studded (285) Coureur (284). Soft only ...	10d.	..
Complete with shoes, nuts and bolts ... ..	1/11	..

## BRAKE SUNDRIES

<b>MAFAC</b> Hood rubber ...	6/-	pair.	With adjuster ...	7/6	pair
<b>G.B.</b> "Arret" half hood with adjuster, similar Mafac ...	5/6	..			
<b>G.B.</b> Hood (state type of lever). White ... ..	4/6	..			
<b>G.B.</b> Lever sleeve. White ... ..	2/-	..			
<b>WEINMANN.</b> Hood. White ...	5/6	pair.	Lever sleeves	1/6	..
<b>CONSTRUCTOR.</b> File pattern grip ... ..	3/9	..			
<b>CONSTRUCTOR.</b> Lever sleeve ... ..	3/-	..			

## CHAINSETS

**CAMPAGNOLO. Double Cotterless.** The long awaited chainset has been undergoing severe testing at the hands of leading Professionals

for the past twelve months, prototypes already have several World Titles and two Major Tours to their credit. Made to the standards expected from Campagnolo the superbly finished alloy cranks are machined to the finest limits, ensuring that both rings run perfectly true. The rings, which are not pressings but machined from solid blanks, fit on square shoulders either side of the crank arms, clamped together by five screwed bushes which are tightened by Allen key. A four-sided taper spline on the axle is locked into the crank by means of a large

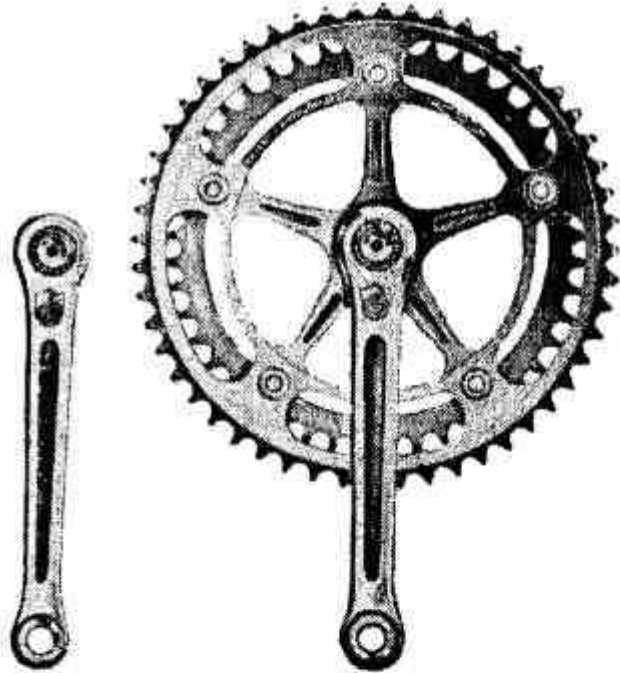

headed bolt and providing all parts are fitted clean and "dry" no further adjustment is necessary. A chrome plate "blanks off" the axle hole and a small plated disc covers the back of the pedal spindle thread maintaining the "immaculate" Campagnolo tradition. Set complete (less tools) ... .. 231/-

**CRANKS** available initially 6¼" only with B/Bracket & Bolts 119/6

**RINGS** from 44T upwards, costing extra when larger than 52T ea. 35/-

**TOOLS.** Extractor tool 9/4 Axle locking spanner 8/6 Allen key 2/3

Bracket cup adjusting peg spanner 1/6 Set of four complete 21/6

## CHAINWHEEL SETS

**WILLIAMS.** B100 6½", 6¾" or 7" from 36—60, 5 pin screw 25/3  
 C34 6½", 6¾" or 7" from 32—60, 3 pin screw or sleeve fitting:  
 Single ... 25/6      Sleeved ... 27/3      C34D double 40/3  
 C45 6½" or 6¾" from 44—50 tooth, 3 pin sleeve fitting only:  
 Single ... 27/3      C45D double ... 40/3  
 N.B. Prices are for up to 48, for larger sizes add diff. on rings below.  
 B100, C34 and C45, 6¾" crank length (fluted) extra per pr. 1/3  
 C1000 6½" only, from 32—60 (C34 pattern ring), 3 pin screw fitting:  
 Single ... 38/9      C1032 double ... 53/6  
 C1200 6¾" only, from 44—50 tooth, 3 pin Continental size fitting:  
 Single screw fitting ... 70/3      C1232 double sleeve fitting 85/3  
 D34 Tandem set 6½", 6¾" or 7", 44, 46, 48, 52 outer ring, 32 or 42  
 drum pattern inner ring. Price complete with front set ... 82/6

## CHAINRINGS

**WILLIAMS.** C34, C45 and B100 ¼" or ⅜", up to 48 tooth 10/-  
 Ditto, in larger sizes 49—52, 11/3; 54T 12/6; 56T 14/-; 58T 15/3;  
 60T 17/9.

Inch Pitch ⅜", extra 2/3 on above, e.g., 23 tooth 12/3.

C1032 double ⅜" screw fitting inner 46, 47 14/-; outer 49, 50 16/-

C1200 Single ⅜" or ⅝" screw fitting 44, 46, 47, 48, 49, 50 13/3

C1232 double ⅝" sleeve fittings, outer 49—52 18/- inner 46—49 14/-

Replacement sets of sleeves, state: single, double ¼" or ⅜" ... 3/3

**SIMPLEX.** Double (set centrally or inside). Inner rings 45—49  
 tooth. Outer rings 48—52 ... 37/6

Ditto, with Dural rings in same sizes ... 49/9

**STRONGLIGHT** Steel, 46—48 14/6; 49, 50 15/9; 52 18/9.

49D Alloy double rings for cotterless set, 5 pin, outer, 49—52 40/-;  
 inner, 44—48 29/6.

No. 57 set. Any two single alloy rings 40—46 25/6; 47—49 27/6  
 50—52 31/6; 53 and 54 39/6; 56 tooth 47/-.

**CHATER** Single. ½" x ¼" 36, 38, 40T 18/-; 42T 18/6; 44T 19/-;  
 46T 19/6; 47T 20/-; 48T 20/6; 49T 21/-; 50T 21/6; 52T 22/6;  
 56T 24/6.

½" x ⅜" 36, 38, 40T 19/6; 42T 20/-; 44T 20/6; 46T 21/-; 47T 21/6;  
 48T 22/-; 49T 22/6; 50T 23/-; 52T 24/-; 56T 26/-.

1" x ⅜" 22T 20/6; 23T 21/-; 24T 22/-; 25T 23/-; 26T 24/-;  
 27T 25/-; 28T 26/-; 29T 27/-.

Double, with adapter, 46/49T 54/3; 47/50T 55/3; 49/52T 57/3.

## CRANKS

**KIDDIE CRANKS.** A heavily chromed fitment that reduces the  
 effective crank length by 2". Quickly and easily bolted on or  
 removed ... 19/6

**CHATER.** Three-arm fluted square cranks 6½", 6¾" or 7" (Price  
 includes cotters and chainwheel bolts) ... 65/- pair

**STRONGLIGHT** No. 55 Competition, 3 pin 6½" 6¾", 7" Steel 47/6

No. 54. Standard, 3 pin 6¾" only, chamfered arms ... 47/6

No. 45. Competition, 5 pin, 6½" and 6¾" ... 42/6

No. 49D Cotterless Alloy, 5 pin, 6½", 6¾", 7" set complete with all  
 bottom bracket fittings and extractor tools, very light ... 112/6

No. 57. Cotterless Alloy, 5 pin, 6½", 6¾", 7". Set complete with  
 all bottom bracket fittings and extractor tools ... 135/-



## CHAINS

**REGINA** 3/32". Made by the famous Italian firm for use with their Freewheel which is "closer" than average. Very flexible because of less width over the rollers, ideal for all derailleur gears 12/9  
**YELLOREX.** French make 1/8" ... 6/8 ..... 3/32" ... 9/10  
**REGINA** 3/16" x 1" block chain as used by World Pros' ... 33/-  
**RENOLDS** 3/16" block ... 58/9 Twin roller ... 11/6

### CHAIN ADJUSTERS

**"ALLEZ" LONG PATH.** Specially designed for use with the heavy-plate W. F. H. Long or Chater Path Ends ... 3/3 pair  
**CYCLO.** For Forward Drop-outs ... .. 1/- ..

### CHAIN WHEEL BOLTS

**CAMPAGNOLO.** Allen key fixing screw and bushed nut 2/6 each  
 No. 12. Ter. Bushed nut, screw, separator for 49D ring  
**CHATER** bolts—set of three bolts ... .. 1/6 set  
**STRONGLIGHT.** Std. 9d. Bushed nut and screw (5 pin) 1/3 each  
 to Ring ... .. 2/- ..  
 No. 57. Bushed nut, screw and washer for 57 set ring  
 to crank ... .. 2/- ..  
 Genuine **WILLIAMS.** For Single ... .. 2d. ..  
**WILLIAMS SLEEVES** (state for which set required) ... 3/3 set

### CHAIN RIVET EXTRACTORS

*N.B.—These extractors are not suitable for use with Renolds Elite chains, which have 'shouldered' rivets.*

**CYCLO RIVOLI** for 1/8" and 3/32" chains, hardened revolving peg. Instructions show how to replace link with remover ... 6/-  
**FIFON** for 1/8" and 3/32". Gunmetal with steel peg. Very compact. 8/11

## COTTER PINS

**CYCLO** (illustrated). Latest asset to the home mechanic. Allows the cotter to be drawn out with a spanner ... 2/1 pair  
**STANDARD** size. Chrome plated 9d. ..  
**CONTINENTAL** ... .. 1/6 ..  
**"ALLEZ"** Extra long. Cadmium plated 1/- pair  
**WILLIAMS.** Chrome plated ... 1/1 ..  
**CHATER.** Heavy chrome. Short 2/6 ..

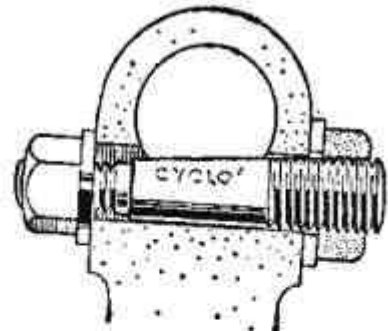

### EMBROCATION, etc.

**ELLIMAN ATHLETIC RUB.** The good old favourite. Made from the finest ingredients ... .. 2/8  
**CURACHO EMBROCATION.** For cold weather ask for "Thermal Curacho" (small size only). Small size ... .. 2/6  
 Large (economy size) ... .. 4/-  
**CURACHO MASSAGE CREAM,** 2 oz. Jar ... .. 2/6  
**BATH SALTS.** Aids relaxation after training. Large tin ... 2/9

### ENTRY FORMS

**R.T.T.C.** Forms (Blank at top) ... .. 4/- per hundred  
 Plus postage 100, 1/-; 200, 1/9; 300, 2/-; 400, 2/3; 500, 2/6.



## MULTIPLE FREEWHEELS

### REGINA GRAN SPORT

The Italian block which is used almost universally on the Continent and in this country. Suitable for use with all gears, it is designed with flush back and narrow body, leaving ample spindle on Quick Release hubs. Claimed to be the smoothest running freewheel, the races, set as far apart as possible, are ground and lapped to take the full amount of  $\frac{1}{8}$ " balls (no spacers). Compare Regina to any other and note the superior finish and smoothness of operation. All cogs detachable 13-28T. The 13 tooth top sprocket requires a different body and second cog to the standard freewheel. Available 13/15 or 13/16, all other cogs are interchangeable.

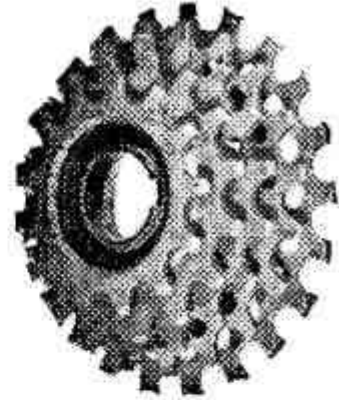

<b>5 SPEED.</b> 13 Top, 15-16 2nd; 14-16 top, 15-18 2nd; 16-20 middle, 17-28 (no 27) bottom two cogs ...	<b>21/6</b>
<b>4 SPEED.</b> (Can be converted into five by exchanging smallest cog for double cog). Sizes as five speed ...	<b>18/6</b>
Bodies only, Standard and for 13 tooth top ...	<b>6/6</b>
Spare sprockets 13 to 28 (no 27) ...	<b>3/-</b>
<b>CYCLO. 3.</b> Top, 13-16; Middle, 17-19; Low 18-28; $\frac{1}{4}$ " ...	<b>25/9</b>
<b>CYCLO. 4.</b> Top, 13-16; 2nd, 17-19; 3rd, 18-25; 4th, 19-28, $\frac{1}{8}$ " ...	<b>29/6</b>
<b>BENELUX 3.</b> Top, 13-16; Middle 15-18; Low 18-28; $\frac{1}{4}$ " Boss ...	<b>21/-</b>
<b>BENELUX 4.</b> Top, 13-16; 3rd, 16-20; 1st and 2nd, 18-28; $\frac{1}{8}$ " ...	<b>25/3</b>
<b>BENELUX 4.</b> Top, 13-16; 3rd, 16-20; 1st and 2nd, 18-28; $\frac{3}{32}$ " ...	<b>24/3</b>
<b>BENELUX 5.</b> Top, 13-16; 3rd & 4th, 16-20; 1st & 2nd, 18-28 ...	<b>28/4</b>
<b>BENELUX.</b> Spare Cogs, $\frac{1}{4}$ " or $\frac{3}{32}$ " 13T to 28T ...	<b>3/3</b>
<b>T.D.C. 3.</b> 16-18-20. Flush back $\frac{1}{8}$ " ...	<b>14/-</b>

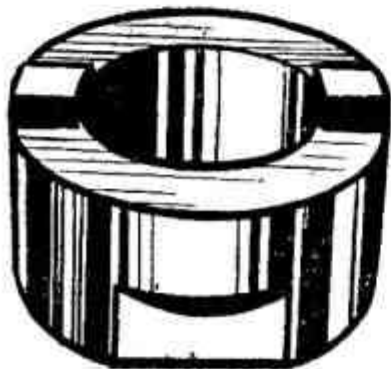

### FREEWHEEL REMOVERS

**REGINA.** Solid block with heavy dogs to engage freewheel. Centre hole large enough to clear Continental hub nuts. Case hardened **3/3**  
**CYCLO** for Standard or Benelux **2/6**

## GEARS

(All Derailleur Spares Stocked)

### CAMPAGNOLO GRAN SPORT

The "KING OF GEARS". Equalled by none; envied by all. Its patented action ensures a rapid and positive change under any conditions. The cantilever arm movement, machined from bronze, obviates the use of a rigid arm which is always liable to accidental damage. The roller bearing cage is fully supported in all positions, being locked to the body instead of "floating" on the end of a shaft. Moving parts liable to wear are reduced to four pins which are

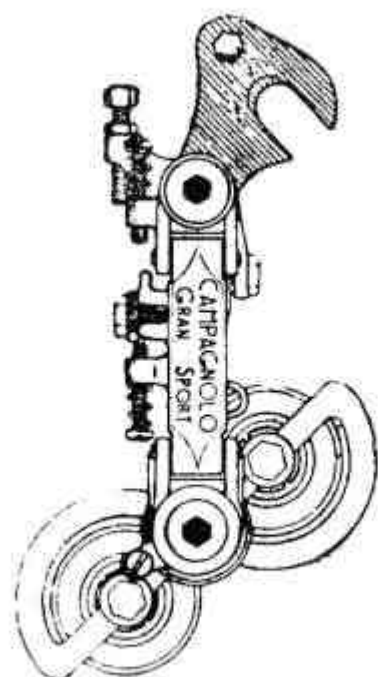

fitted with phosphor-bronze bushes, whilst the two pulley wheels are of exceedingly hard-wearing high tensile steel. The precision workmanship, the materials used and the excellent finish combine to produce a gear which will give first class service.

**Dominating the Continent again in 1959. Winning all the major Tours and Classics including the Tours of France and Italy.**

**GRAN SPORT Gear** ... 80/-  
**With Bare Cables and Clips** 85/-

**GRAN SPORT FRONT CHANGER** ... 50/-

**With Bare Cables and Clips** ... 53/6

**ENSEMBLE (front and rear, with twin lever)** ... 130/-

**With Bare Cables and Double Clips** ... 138/6

**Pump-holder, incorporated in Lever** ... extra 2/8

**Handlebar control** ... extra each gear 6/-

**Sport Gear. Single roller (16-22 only)** ... 43/6

**Sport Front Changer (Hand operated)** ... 23/4

### CAMPAGNOLO SUNDRIES

**Lever Rubbers** ... 1/-      **Transfer** ... 6d.

**Allen Key** 2/-; **Roller Cone Spanner** 1/-; **Spoke Disc** 3/4

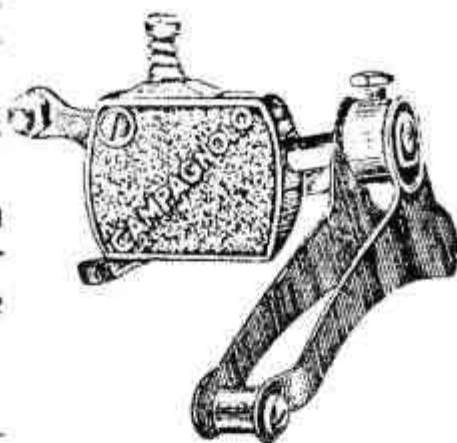

## BRITISH BENELUX

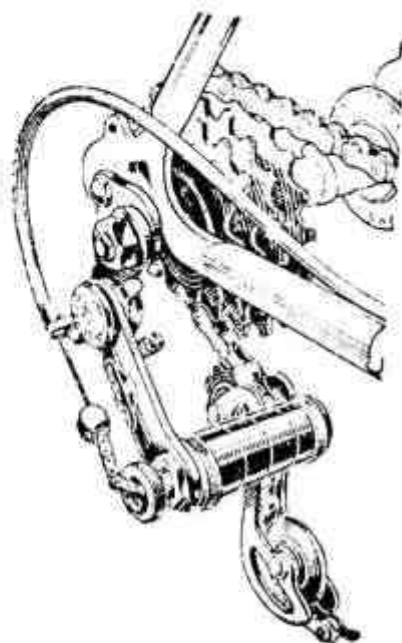

**MARK 12.** Pre-selective, with automatic roller tension. Plastic lever damper ... .. 50/-

**MARK 7 (illustrated).**

Improved version of the popular Benelux gear with redesigned roller cage, for either  $\frac{1}{8}$ " or  $\frac{3}{16}$ " chain. Adjustable arm movement stop and simple chain tension control ... .. 31/6

**MARK 7 ENSEMBLE** with twin lever cable control to Mark 7 gear and "SHIF" front changer ... .. 64/-

**"SHIF" FRONT CHANGER.** Cable operated from left-hand lever, for  $\frac{1}{8}$ " or  $\frac{3}{16}$ " chain ... .. 28/4

**"SHIFWIN"** ditto with twin lever 38/4

**"SHAN" FRONT CHANGER.** Rod control from swivel clip on seat tube giving positive change over Tourist and Racing ratios ... .. 26/3

**MARK 8 Tourist Gear.** For use with wide ratios—designed to operate with sprocket range of 13—28T, and chainwheel "jump" of up to 15 teeth. Fitted from rear drop-out with long jockey arm to cope with greatly varying chain length ... .. 35/-

**N.B.—Comprehensive range of spares for Campagnolo, Cyclo, Simplex and Huret Gears available from stock.**

## SIMPLEX

**"JUY 543"** (illustrated). Preselected gear 3, 4 or 5 speed with working parts enclosed by oilbath against wet and dirt

79/6

**"JUY 51"**. Coupled tension model, automatic adjustment on rollers, 4 or 5 speed ... .. 47/6

**"JUY 59"**. Improved double roller assembly giving extra chain-wrap... 45/-

**"T.D.F. De Luxe"**. Double Nylon silent running rollers. 3 x  $\frac{1}{8}$ " and 4 x  $\frac{3}{16}$ " 29/11

Ditto 4 x  $\frac{1}{8}$ " and 5 x  $\frac{3}{16}$ " 32/6

**"303 Touriste"**. Fitted from drop-out allows use of wide ratios. 3, 4 or 5 speed ... .. 35/-

**"JUY 56" FRONT CHANGER.** Controlled by twin levers (the price includes parts to adapt single right lever to twin)

35/-

**"LJ 23"**. Cable-operated Changer for two or three rings ... 45/-

**Competition De Luxe.** Hand-operated changer ... .. 25/-

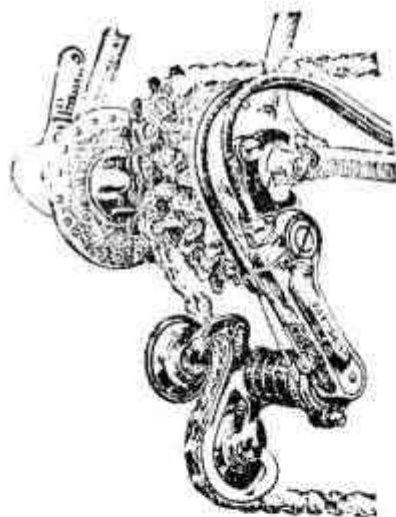

## HURET

**ALLVIT.** The star of the Huret range employing a moving parallelogram action, adjustable for 3, 4 or 5 speeds, drilled double rollers for adequate "chain-wrap" ... 80/-

**ALLVIT ENSEMBLE.** Front and rear gears with latest twin lever ... 97/6

**"Champion du Monde". "BOBET"** twin roller gear with separate cable tension adjustment ... 42/6

**"TOUR de FRANCE".** The cheapest double roller gear ... 29/6

**FRONT CHANGER.** Cable ... 31/-

**Hand-operated** ... 25/-

**T.D.F. Ensemble, double levers** 51/-

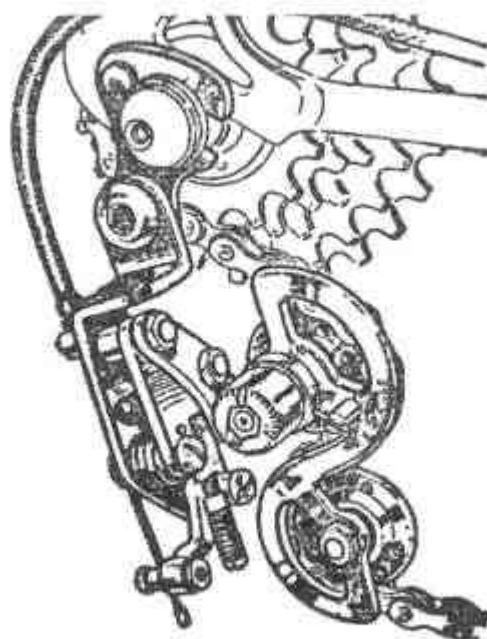

## STURMEY ARCHER HUB GEARS

Wide Ratio.	A.W. 3 speed ...	47/8	F.W. 4 speed ...	51/1
Medium Ratio.	A.M. 3 speed ...	47/8	F.M. 4 speed ...	47/8
Close Ratio	A.C. 3 speed ...	55/9	F.C. 4 speed ...	55/9

## HANDLEBAR BENDS

**COPPI ROAD.** The genuine Coppi Road Bend in strengthened alloy. One of the most popular bends here and on the Continent ... 22/6

**"ALLEZ".** Maes bend—the shape still most commonly used both here and on the Continent. In heavy gauge alloy,  $\frac{1}{8}$ " diameter with bulged centre for rigid fitting in stem.  $15\frac{1}{8}$ " wide ... 12/6

**CINELLI.** The famous Italian Chrome Steel Bend with brilliant finish.  $\frac{1}{8}$ ". Six shapes, as below, all at ... 20/-

No. 11 San Remo  $15\frac{1}{4}$ " x 7". No. 12 Gran Fondo  $14\frac{7}{8}$ " x 7". No. 13 Koblet  $15\frac{1}{4}$ " x  $6\frac{1}{2}$ ". No. 15 Tour of Britain  $15\frac{1}{4}$ " x  $6\frac{1}{4}$ ". No. 16 Campione del Mondo  $15\frac{1}{4}$ " x  $5\frac{1}{4}$ ". No. 17 Corsa Strada  $14\frac{7}{8}$ " x 6".

**TRACK BENDS** in heavier gauge steel, No. 14 Pista  $14\frac{3}{4}$ " x  $7\frac{1}{2}$ ". No. 18 Madison  $14\frac{1}{4}$ " x  $7\frac{1}{4}$ " ... 24/-

**ENGRAVED Ferrule.** Engraved as follows: No. 15 Tour of Britain, No. 16 Campione del Mondo. No. 17B Giro d'Italia ... 24/-

**G.B. ALLOY,** with smart ferrule. Maes, R. H. Maes, Capo Berta, Pelissier, Olympic, Road Champion, Tourist  $15\frac{1}{2}$ " ... 16/6

**G.B. All-rounder.** Flat with bulged centre ... 12/-

**G.B. EMBOSSED STEEL.** Maes, R. H. Maes and Road Champion ... 18/-

**DAWES Engraved Alloy.** Concorde, Compass and latest Certes 16/6



## HANDLEBAR STEMS



**IL PRIMO** (illustrated). Popular steel stem of strong lapped design with extension sloping slightly to drophead clip. Chromed with attractive three colour badge giving very distinctive finish. Excellent value.

2½"	2½"	...	...	...	...	17/-
3½"	...	...	...	...	...	18/-
3½"	...	...	...	...	...	19/-
4½"	...	...	...	...	...	20/-
4½"	...	...	...	...	...	21/-

**CINELLI.** Increasingly popular, this fine Italian stem is renowned for the strength of its extra wide clip and heavy chrome finish.

2½", 3½", 3½", 4½", 4½" or 5½" ... .. 27/-

**CINELLI BADGED** stems, sizes as above. Very smart ... 30/-

**G.B. Hyduminium Alloy—Expander** 1½" ... 16/-

Ditto, 2½" ... 18/-      3½" ... .. 19/9

**G.B. KROMO Steel—**

2½", 3", 3½" ... 25/-      4", 4½", 4½" ... 26/6

5", 5½", 5½" ... .. 28/6

**G.B. KROMO Underslung** (illustrated)—

3½", 4½" ... 27/6      5" ... .. 28/6

**G.B. KROMO Merkens** (downward curve) 27/6



## HANDLEBAR TAPE

There are many tapes available but "Allez" Twill and "Quelda" Plastic still maintain their place as the most popular. With their full 5-yard rolls and ¾" width they are the best value obtainable.



**TWILL.** Stout Herringbone pattern. In Black, White, Blue, Yellow, Red, Green ... 1/11 roll

**"QUELDA" EMBOSSED PLASTIC.** Self-adhesive. In Black, White, Blue, Yellow, Red, Green ... .. 1/9 roll

**GEM Embossed Plastic** in 3 yard x ¾" rolls. Black, Green, White, Red, Blue and Ice-Blue.

**Translucent.** Ruby, Emerald, Magenta and Sapphire Blue 1/- roll

## HANDLEBAR END PLUGS

**CONSTRUCTOR.** The new plug with containers. Complete with solution and patches—room for spare bulbs, etc. ... .. 5/6

**SHOCKSTOP** all rubber. In Claret, Blue, Black, Green, Beige and Grey ... .. 1/- pair

**DUNLOP.** Black, Red, or Off White, with expander screw 2/6 ..



## HEAD FITTINGS

### CAMPAGNOLO (illustrated).

The famous Italian firm offer two models, both precision ground for absolute accuracy the races being highly polished and coated with special hard chrome. The ROAD model is fitted with 22 x  $\frac{1}{10}$ " balls and the PATH with 26 x  $\frac{5}{32}$ " balls in each race. Providing care is taken to fit absolutely true these sets will give many years of perfect service ... .. 39/6

**ALLEZ** A Continental set employing  $\frac{5}{32}$ " cup and cone inserted races (fit 24 balls) with deep tooth serrated locking washer for positive non-slip adjustment.

Really exceptional value ... .. 7/6 set

**STRONGLIGHT Competition.** Best French set with proven V races, giving double bearing surface for extra life ... .. 24/6 set

**STRONGLIGHT P3.**  $\frac{5}{32}$ " inserted races 18/6 ..

**T.D.C. Continental "S".**  $\frac{5}{32}$ " inserted V races for 20 or 22 gauge head-tubes. Decagon serrated screwed race and locking washer for easy adjustment ... .. 9/- set

**T.D.C. Continental "J".**  $\frac{5}{32}$ " inserted cup and cone races 20 or 22 gauge ... .. 5/3 set

**CHATER-LEA.** Head clip sets complete 17/7

**CHATER-LEA. Tandem.**  $\frac{3}{10}$ " balls ... 23/4



## HUB COGS

$\frac{1}{2}$ " x $\frac{1}{8}$ " 12T to 16T ...	1/11	17T to 22T ... ..	2/-
1" x $\frac{3}{16}$ " 6T to 9T only. Central set ... ..			2/7
B.W. $\frac{1}{2}$ " to $\frac{3}{16}$ " 14T to 22T ... ..			3/4

## HUB TRACK NUTS

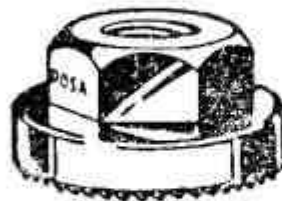

**CAMPAGNOLO.** Designed for the Record solid spindle hubs and machined to the usual fine limits and finish ... .. pair 7/4

**"ROSA"** (as illustrated).

Bright cadmium ... .. 1/11 set of 4

Chromed ... .. 2/4 set of 4

**"VENDOME"** (Domed).

Chrome only ... .. 3/8 set of 4

## HUB WING NUTS

<b>G.B.</b> alloy lever pattern, front or rear ... ..	pair	4/6
<b>G.B. STURMEY</b> pattern ... ..	pair	5/6
<b>HURET</b> Chrome Plated Bronze, set of four ... ..		6/6
<b>WEINMANN</b> Polished Alloy, set of four ... ..		9/-
<b>WEINMANN</b> Anodised Red or Blue, set of four ... ..		10/6

## HUBS

### CAMPAGNOLO

#### SOLID ALLOY RECORD

The very best. Used by Riviere during his amazing Hour Record. With solid spindle for track use, also fitted with Quick-releases for road work. Both types available drilled 32 x 40, 36 x 36 and 28 x 28.

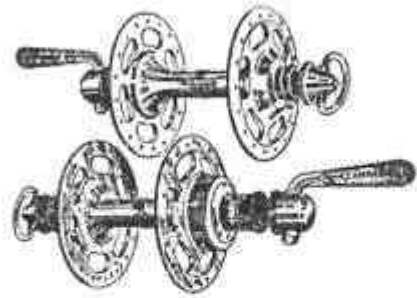

**TRACK.** Large flange and single fixed only... 85/- pr.

**ROAD Q/R.** Single gear sided only:

Small Flange	...	...	...	...	...	87/6 pr.
Large Flange	...	...	...	...	...	117/6 pr.

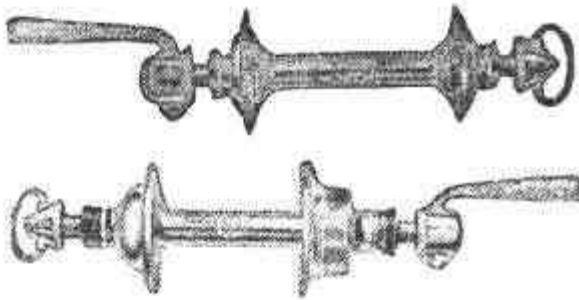

**GRAN SPORT** Alloy flanges on hard chromed steel barrels, with the original and unsurpassed *single finger* Q/release blocage. 32/40, 36/36, S/S/G, G/F, D/S/F.

Large Flange	...	99/9
Small Flange	...	69/9

**SOLID SPINDLE.** Gran Sport hubs as above less Quick releases. Available drilled 32/40 and 28/28 holes.

Large Flange.	S/S/G, G/F, D/S/F, S/S/F	...	72/6 pr.
---------------	--------------------------	-----	----------

Small Flange.	S/S/G, G/F, D/S/F, S/S/F	...	42/6 pr.
---------------	--------------------------	-----	----------

#### F.B. SOLID SPINDLE HUBS.

Small Flange.	Gear/Fixed.	32 x 40 only	...	...	37/6 pr.
---------------	-------------	--------------	-----	-----	----------

S/S/Gear.	36 x 36 and 32 x 40 only	...	...	37/6 pr.
-----------	--------------------------	-----	-----	----------

S/S/F and D/S/F.	36 x 36 and 32 x 40 only	...	...	39/- pr.
------------------	--------------------------	-----	-----	----------

Large Flange.	All drillings at the same price	...	...	75/- pr.
---------------	---------------------------------	-----	-----	----------

S/S/G and G/F.	36 x 36 and 32 x 40 only.			
----------------	---------------------------	--	--	--

S/S/F and D/S/F.	36 x 36, 32 x 40 and 28 x 28 holes.			
------------------	-------------------------------------	--	--	--

<b>CHATER-LEA</b>	small flange only.	Front	...	...	20/- each
-------------------	--------------------	-------	-----	-----	-----------

Track nuts	...	2/6 pair	Rear D/S or G/F	...	27/6 ..
------------	-----	----------	-----------------	-----	---------

<b>CONSTRUCTOR.</b>	Quick Release Conversion Set.	Skewer pattern.			
Set for rear wheel	...	...	...	...	12/6

## HUBS (continued)

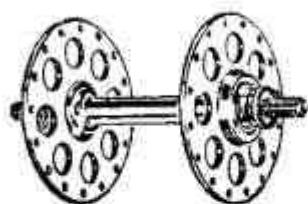

### BRITISH HUB Co.

Most popular range of hubs which caters for all purposes.

**AIRLITE** with sturdy alloy flanges set on chrome plated steel barrels. Many types available.

**LARGE FLANGE "Continental"** (illustrated) drilled flanges ... .. 76/6

**Quick Release** model ... .. 97/11

Coloured Flanges, Red, Blue, Green, or Gold (32/40 only) extra per pair ... 3/7

### AIRLITE SMALL FLANGE.

All types and drillings ... .. 48/-

**Quick Release** (as illustrated) 69/-

### AIRLITE TANDEM

**LARGE FLANGE "Continental"** 84/5

**SMALL FLANGE** all types ... 58/9

**SOLITE.** Small flange only, all steel, solid barrel ... .. 26/6



**SOLITE TANDEM.** Available in all types of threadings ... 31/6

**RACELITE.** All alloy Large Flange Racing Hubs, all types 35/11

**HUB BRAKES.** **Super Tandem** complete with steel brake levers and cable-cum-rod controls. Gear sided only with 4" internal expanding drum brakes, efficient in all weathers ... .. 113/9

**Super Special Tandem** as above but with larger 4 1/2" brake drums 125/-

### BAYLISS WILEY

First class small flange hubs for racing purposes. Hiduminium flanges set on chrome plated steel barrels machined from the solid, combine lightness and strength in a finely finished hub.

No. 23 front ... .. 16/2 No. 25 rear (G/F only) ... 21/6

Popular all steel small flange hub for general use.

No. 51 front ... .. 6/- No. 10 rear (D/Fixed) ... 11/2

No. 310 rear (G/Fixed) ... .. 9/-

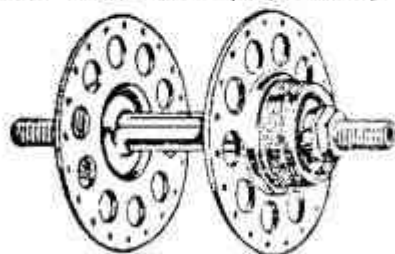

**"CONTINENTAL".** Large flange popular priced (as illustrated).

Front (No. 19) ... .. 30/3

Rear (No. 20—double fixed) ... 35/-

Rear (No. 21—gear and fixed) ... 35/-

Rear (No. 22—single gear) ... 35/-

**A comprehensive range of spares for all hubs listed: Campagnolo, F.B., Chater, B.H. Co. & B.W., are stocked.**

## LAMP BRACKETS

**CONSTRUCTOR CONLOY** with snatchproof screw, in polished alloy ... .. 4/-

**CHATER-LEA** steel, right or left hand, chrome... 2/9½

Steel, cadmium plated ... .. 1/9

N.B.—Above are for brazed-on bosses and are complete with securing bolts.

**PETERS** (Illustrated). A very neat spring steel clip-on bracket clamped with bolt to the handlebar 2/3

**TERRY**. Handlebar lamp bracket Wing-nut fitting. Chrome ... 2/6

**TJQ**. Chrome plated heavy wire H/bar bracket w/clamping bolt 2/6

**TERRY**. Basket pattern. Clips over handlebar, lamp hanging below. Silver ... .. 1/6

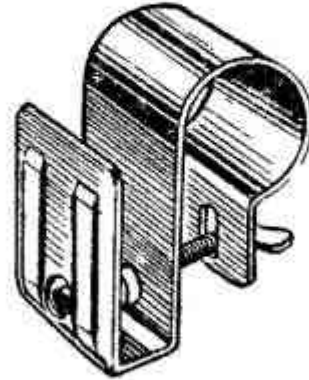

## LUCIFER

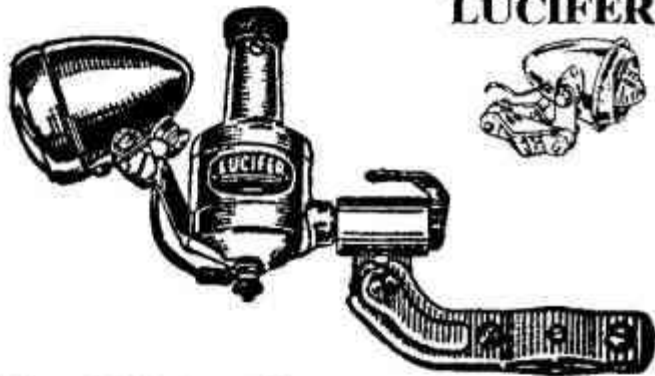

**Two years' guarantee.** Superior Workmanship and finish. 6 v. .5 amp. We only stock and recommend these as we have found no equals. The following include the famous 800 "Baby" Dynamo.

No. 807 (as illustrated) "Combi" ... .. 50/-

No. 820A "Aero". Neat separate headlamp ... 55/-

No. 816A "Lux". Long beam headlamp ... 55/-

No. 814A "Aero-Bi". With two bulbs ... 59/6

No. 819A "Bi-Lux" ... .. 59/6

No. 809A "Battery". Standby battery ... 59/6

No. 822A "Focus" ... .. 62/6

**PULLEY RUBBERS.** "Luci-Grip". Saves tyres 9d.

## LUBRICATORS

**Tecalemit nipples**, 3/8" diameter ... .. 4½d. each

**Oil-gun** for Tecalemit nipples—"Visigun" ... 5/3

**DERMIC OILER.** Ideal for the lubrication of Continental hubs, gears and freewheels that have tiny oil inlets. Operate as hypodermic ... .. 5/6

## MAPS

Bartholomew's 1/2" (based on Ordnance) on cloth ... 5/- each

Dissected ... .. 10/- "



## PEDALS

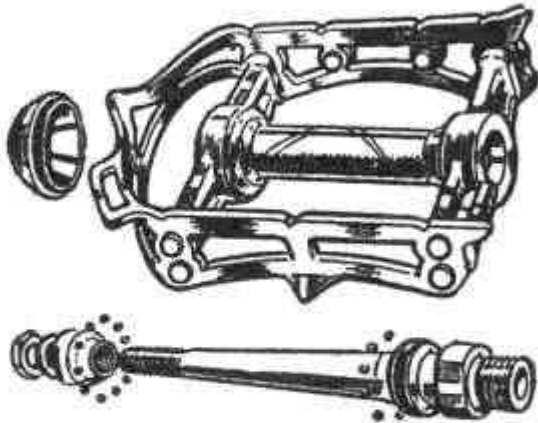

**CAMPAGNOLO.** Used by all the top Continental Road-men and leading Trade teams, and now firmly established as the finest pedal ever produced, and a worthy addition to the famous Campagnolo range of accessories. The highly polished alloy barrel of forged single unit construction, houses races which, following modern engineering practice, utilise a special hard chrome finish for exceptional bearing life. The spindle is of Nickel Chrome,

ground and polished between centres, the bearing radius and cone being finished in the same hard chrome as the barrel races. A friction-free oilseal concealed between the barrel and spindle combines with the perfectly fitted dust-cap to effectively prevent any dust penetrating. The frame of best quality steel, exceptionally heavily chromed, further demonstrates the careful planning behind all Campagnolo products. Two special clips retain the toe-strap in the correct position for use and assisted by a small projection on the back plate, enable the clip to be "picked up" smoothly. Special provision is made for the correct positioning of the toe clip by two neat chrome-plated studs set in the front plate. ... 72/- per pair

**TRACK MODELS.** Have barrel as Road pattern but are fitted with side plates three inches wide, which having no extended Quill do not protrude beyond spindle length. Available with or without serrated frame edges. Either pattern ... 72/- per pair

### CHATER-LEA

**"Sprint".** In stainless steel Single-sided for maximum ground clearance. Smooth-edged to accommodate shoe plates,  $\frac{5}{16}$ " balls ... 32/-

**Standard.** Double-sided stainless steel, spindles and cones precision ground ... 32/-

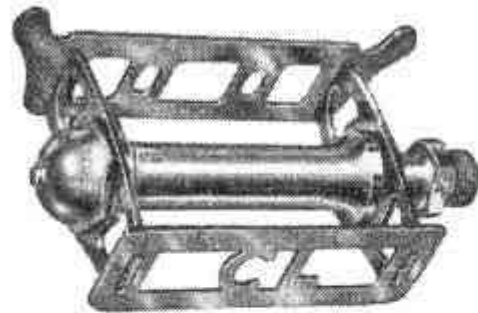

### CONSTRUCTOR

**Boa.** Quill pattern made throughout of best quality steel. Chromed. Adjustable width  $3\frac{1}{2}$ " to 4" ... 29/6

**Viper** double sided ... 21/6

**Asp.** Platform type ... 22/6

**Cobra.** Quill pattern ... 21/6

**SPARES and REPLACEMENTS** stocked for all pedals listed above.

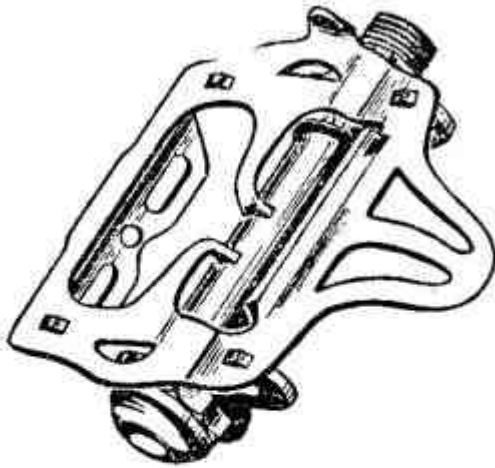

## PEDALS (continued)

### LYOTARD

Ever increasing in popularity we have found it necessary to increase the range of these French pedals for 1960. Following reductions in price without, we stress, any sacrifice of their high quality, they are unsurpassed for value within this price-range. Among those

listed below are types suitable for racing, touring and every-day cycling.

*All spares are stocked and listed below.*

**No. 23. Marcel Berthet.** As illustrated. Platform type, it will fit any cycle shoe, and is firmly established as the choice of British roadmen. Weight only 11 ozs. **15/9**

**Faucheux Road.** Solid barrel with a single-sided, open-ended frame with serrated edges. Width  $3\frac{1}{2}$ ". 13 ozs. **14/-**

**No. 15S.** Similar shaped frame mounted on a longer spindle. Very popular.  $3\frac{3}{8}$ " wide. Weight 14 ozs. **13/3**

**No. 15 Bis. Tour de France.** Double-sided serrated frame on solid barrel. Width  $3\frac{1}{2}$ ". Weight 15 ozs. **13/3**

**No. 45.** A quill pattern pedal in steel throughout with shorter solid centre barrel. Width  $3\frac{1}{2}$ ". 13 ozs. **14/-**

**No. 45 CA.** Similar to above but with alloy frame on the steel barrel. Only 11 ozs. ... .. **15/3**

**No. 460A.** Double-sided frame on a simple tubular barrel for general use.  $3\frac{1}{2}$ " wide. Weight  $13\frac{1}{2}$  ozs. **9/-**

**No. 462.** As above but single-sided frame.  $12\frac{1}{2}$  ozs. **8/11**

**Lyotard Spares.** Cones ... 2d. ea. Dust caps ... 6d. ea.

Spindles complete. Two lengths  $3\frac{1}{4}$ " and  $4\frac{1}{2}$ " ... **1/9** ea.

### PHILLIPS

**Credalux** steel chrome quill pattern ... .. **16/3**

**Apollo.** Double-sided steel ... .. **8/9**

**WEBB.** The well-known quill pattern pedal ... **16/6**

## PUMPS

**APEX Grand Prix.** 18" polished alloy, with inserted brass connector block. Very sturdy, Racing man's pump. Red, White and Blue rings. Large diam. ... 9/-  
**"Ultralite Racing".** As above but  $\frac{7}{8}$ " diam. ... 6/6

### BLUEMELS

**"Tour of Britain".** 1" diam. Alloy Pump with coloured plastic ring-grips. 18" only ... .. 10/6

**"Air-Weight"** polished alloy 15" 5/9 18" 7/-

**"Lightweight"** White or Black 15" 5/11 18" 6/11

**ZEFAL.** The Continental Alloy Pump.

Polished ... 18" 8/9 Coloured ... 18" 10/6

## PUMP CONNECTIONS

**BLUEMELS.** No. 9 Standard 1/- ea. 9a H.P. 1/- ea.

**P.9.** Fits ordinary or H.P. valves ... 1/4 ea.

**ZEFAL.** Continental for H.P. valves ... 1/6 ea.

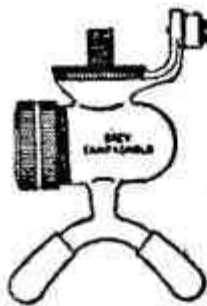

**CAMPAGNOLO.** (As illustrated). Heavily chromed, push-on adapter with locking grub screw and rubber cushioned feet to fit the curve of the tube when used without a pump-peg. English or metric thread ... .. 8/10

**A.F.A.** alloy, push-on adapter ... 1/9

## PUMP CLIPS

**CAMPAGNOLO "Portapompa".** Usual finish associated with this name.

Single Pump Peg for seat or top tube 3/-

Pump holder for seat or top tube 6/-

Combined with single gear lever 14/8

Combined with double gear lever 26/8

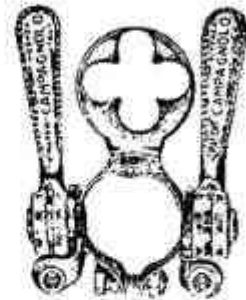

Any of the above pump holders can be used with the screw-on adapter (as above) or the combined holder and gear wire channel stop for Seat-tube or Down-tube pump position. (State which type) ... .. 6/8

**MINIMA.** Latest French screw-on clips of attractive design. Heavily chromed. Down or Top Tube pair 2/9

**TERRY'S.** Chrome 1" x  $\frac{7}{8}$ " Push-on spring clip pair 2/6

## RIMS—SPRINT

**FIAMME.** The rim fitted with the "Longhi" patent design (as shown) will lace up into a really tight wheel. The spoke pull is equally carried by both faces of the rim, giving a rigidity which will hold the wheel true when under the stresses of racing. Used by the majority of Professional Roadmen, who compete over poor road surfaces. In two weights, for ROAD (14 ozs.) or TRACK (12 ozs.) drilled 32/40, 36/36 or (Track only) 28/28 holes. 27" only ... .. 49/11 pair



**MAVIC.** The famous French rim of similar design ... 65/- pair  
**WEINMANN** alloy. 13 oz. 27" only ... .. 57/6 ..  
 or Wood-lined as Continental practice. 11 ozs. ... 57/6 ..  
**CONSTRUCTOR.** Conloy. Weight 12½ ozs., 27" ... 54/- ..

## RIMS—WIRED-ON

**FIAMME.** Famous Italian Alloy Rim. 18 ozs. Special design giving extra strength. 27" only. A well-finished and dependable rim. Now with unpolished surface for wet weather braking ... 39/6 pair



**WEINMANN ALESA.** First-class Swiss 27" H.P. rim with dimpled spoke holes. Weight 19 ozs.

40/- pr.  
 26" non-dimpled only 40/- pr.

**ENDRICK** 26" or 27" by 1¼" only ... .. 45/- pr.

**CONSTRUCTOR.** Made from Conloy material; claimed to be the strongest alloy.

**ASP.** "The Best", 26" or 27", weight 17 ozs. ... .. 66/6 pair

**COBRA.** The lightest. 26" or 27". Weight 16 ozs. ... 61/- ..

**BOALOY.** 26" or 27". Weight 24 ozs. ... .. 46/- ..

## RIM TAPES

Rubber rim tapes for H.P. rims ... .. 1/6 each

**CONSTRUCTOR.** Round section to fit into deep-welled rims 2/- ..

## SPRINT WHEEL CARRIERS

**CLIFF PETERS.** Extremely tough alloy, with open-ended slot for front spindle and side opening slot for carried wheels. Very light, suited for use with Q/R hubs. Polished or coloured ... 4/11 pair

"CYCLO'S" "Rosa" in steel ... .. 4/9 ..



## SADDLES and SEAT PINS



### CAMPAGNOLO—BROOKS

For the 1960 season these two famous names have worked in co-operation and produced a standard of combined saddle comfort and practicability never before offered to the racing cyclist.

Campagnolo's seat pin is now universally acclaimed for strength, rigidity and meticulous adjustment. Now, in addition to the standard model, he is offering one with a narrow cradle

to accommodate a specially designed saddle by Brooks, which has a top of the Continental "Competition" shape, without bag loops, mounted on a new narrow-wired frame. This ensemble "par excellence" besides being lighter than the standard model, allows exactly twice the amount of lateral adjustment.

**SEAT PIN** in sizes 3, 4 and 5. Highly polished alloy ... 39/6  
**SADDLE. "Campag" Competition.** Straight wire pattern. 1 lb. 3 oz. 42/6

**CAMPAGNOLO** Standard Seat Pin with cradle to take the normal shaped two-wire saddle. Also available in sizes 3, 4 and 5 39/6  
**N.B.—Ensure that pin is correct size required as the shaft is highly polished alloy—easily scratched and rendered unsuitable for resale.**

**BROOKS.** The leading saddle makers in the world.

**SWALLOW** (illustrated). The cut-away saddle that gains in popularity each year. Designed to eliminate chafing on long distance rides.

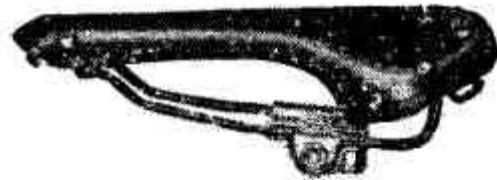

B.17 Chromed ... 67/6  
 B.15 Chromed ... 35/-  
 L.15 Chromed ... 25/-

**B.17 SERIES.** Narrow 11" x 6" x 3½" 1 lb. 10 ozs., Sprinter 11" x 4¾" x 2½" 1 lb. 7 ozs. Standard 11" x 6¼" x 3⅛" 1 lb. 12 ozs. Flyer 11" x 5" x 3" 1 lb. 8 ozs. Any of this series.

Black frame (ex sprint) ... 45/- Chromed ... 47/6

**B.17 Competition** 11" x 6¼" x 3⅛" 1 lb. 7 ozs. No bag loops. Chr. 48/6

**B.15 SERIES.** Narrow, Standard, Flyer (sizes as B.17 above).  
 All in Black ... 32/6 Chromed ... 35/-

**BRISTOL. CL3.** Similar to B15 Std. En 16/- Swallow Chr. 18/9

**B66 Champion.** Wide back, coil springs ... 38/-

**MANSFIELD.** No. 42 Sprint 11½" x 4½". Black ... 26/-

**Bath Road.** Cut-away. Chrome 30/-. **Ace.** Cut-away laced under 25/-

**WRIGHTS 56L.** Leather cut-away top supported by coil springs 26/9

**BROOKS PROOFIDE.** For allweather saddle protection 1/10½ tin

## SPANNERS

<b>CAMPAGNOLO.</b> Cotterless Extractor Tool ... ..	9/4
Cotterless bottom bracket axle spanner ... ..	8/6
Peg spanner ... 1/6	Allen "L" key with grip ... 2/3
Allen "T" key with box spanner ... 2/6	Allen "L" key ... 2/-
Pedal dust cap and lock nut spanner 4/4	Roller cone spanner 1/-
<b>MAFAC.</b> Complete tool set in neat container only 3½" x 2½" with ten spanners, screwdriver, nipple-key and puncture outfit. Fits all Continental bolts on Brakes, Gears, etc. Metal tin 10/6. Plastic pouch 12/11	
Box spanner available separately, for fitting Brake lever ...	9d.
<b>INOX.</b> Continental Bronze 8-way box ... ..	3/-
<b>TERRY</b> Pedal Spanner—the right tool ... ..	4/-
<b>CYCLO</b> spanners—Std. Cyclo ... 1/3	Mark 12 ... pair 3/6
<b>BROOKS</b> Saddle Spanner ... 2/6	Six-way ... 1/3
Also Head and B.B. ... 1/3	Peg and Cone ... 1/-
<b>SPOKE KEYS.</b> Brooks disc ... 1/-	Cyclo one-way ... 1/6
<b>AIRLITE</b> hub cone spanners ... ..	pair 2/-

## TOE STRAPS

The 'ALLENZ' CORSA. With slit to tuck the end of the strap in, giving perfect "stop". Quick release buckle. Leather specially selected to avoid stretch 4/9 pair  
Coloured Red or Blue 5/3 "



**BINDA.** Genuine Italian strap used by Coppi and leading sprinters. Really tough, Red finish ... .. 6/- pair  
**LAPIZE.** Leading French straps with a serrated roller in the buckle—definitely non-slip. Red, Blue or Natural ... .. 5/6 pair  
**CONSTRUCTOR.** New Gold strap matching Bronze clip 5/9 "  
Standard quick-release strap 4/3 pair Super Red Polished 5/6 "  
**BROOKS** No. 1 de Luxe. Red Leather ... .. 4/6 "  
**BROOKS** No. 1 Standard ... .. 3/9 "  
"FLIK". Fitted quick-release wide buckle ... .. 3/3 "  
**COLLEGE DE LUXE** ... .. 2/3 "

## TOE CLIPS

**G.B. "Type Professional"** (As illustrated).  
Stainless steel, long or short ... .. 6/6  
**CHRISTOPHE,** in three lengths. Most famous of French clips ... .. 6/6  
**LAPIZE.** French Medium size only 5/9 pr.  
**CONSTRUCTOR.** New rolled bronze spring clip. Gold non-rust finish. One size only 7/9 pr.  
**CONSTRUCTOR** steel or Boa pattern ... 5/3  
**BROOKS** No. 1. Best Steel, chrome plated three lengths ... .. 5/9  
**ASHBY** "Wanderlust" 4/9 "Monique" 4/9



# D'Alessandro

## TUBULARS

Registered Trade Mark

This year, as in many seasons past, we again confidently expect the majority of successes to be gained by riders using D'Alessandro tubulars. These tyres, ridden throughout the years by World and National Champions alike retain their steadfast popularity, by performance, reliability and long service.

Favourite among Continental Aces, and designed to meet their many exacting demands, these tubulars are the first choice of all discerning British Riders.

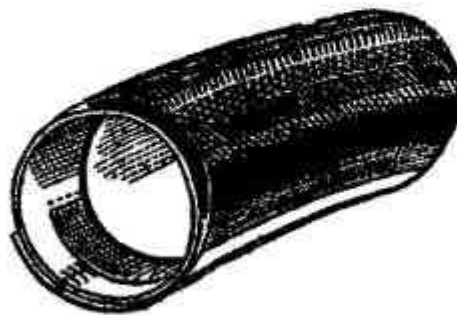

**IMPERFORABILE** (illustrated above) Recognised everywhere as being "THE JOB" This fine tyre although light will give an incredible number of racing miles and proves to be an economical purchase for the serious racing man who competes at all distances. 9½ ozs. Elastic raw rubber strip between a very hard rubber tread and the light "Sea Island" cotton pocket, is the secret of its durability and of its amazing resistance to punctures. Usually with file pattern but can be supplied with matt tread ... .. 69/11  
Or with SILK Fabric ... .. 87/6

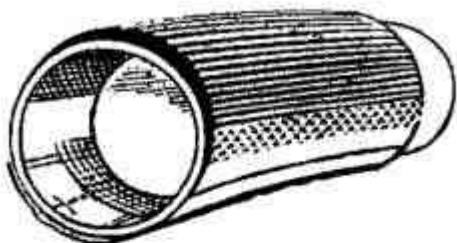

**LIGHT ROAD.** A new, fast Road Tyre with distinctive orange coloured multi-ribbed tread (illustrated) which can be used with confidence on either wet or dry surfaces. Although only 8½ oz. in weight its toughness was early demonstrated during International Competition last year. Recommended for fast "50s" ... .. 62/6

**GIRO D'ITALIA.** A fine road tyre for hard wear. Not quite so "pricey" as the Imperforabile it will never-the-less give many miles of speedy racing. Narrow black file pattern tread with latex sides. Weight 10½ ozs. ... .. 57/6

**PRIMO.** A hand-made tyre with a light fabric carrying the narrow hard-wearing matt tread. Fitted with an extremely light "dimpled" inner tube and cotton base tape, this tyre weighing only 8 ozs. is eminently suitable for pursuits and fast short distance road events ... 57/6  
Or with SILK Fabric ... 75/-



**IMPERIAL.** A reliable road tyre for all-round work. Narrow black tread with non-slip design. Latex sides. Weight 13 ozs. ... 43/6

**SPORT** (as illustrated).

An entirely new tyre designed to meet the needs of present day road racing, when cost has to be taken into consideration. This tubular has a very fast centre band of narrow ribs, flanked by sure-grip file pattern tread edged by further twin non-slip ribs.

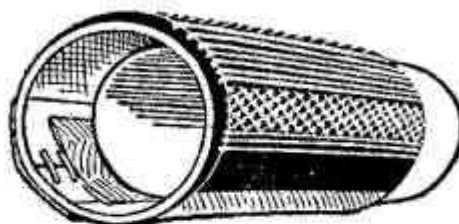

The robust, open-sided pocket is set on a fully rubbered base tape. Weight only 13 ozs. ... .. 35/6

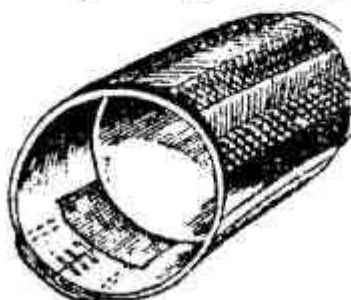

**VULCAN** (as illustrated).

An ideal every-day tyre with ever popular Italian style file pattern tread on open sided pocket. Not a "hose-pipe" but a lively tubular with light inner tube not normally expected at this price. The many good reports received when this 14 oz. tyre was introduced last year stress the very good value at 29/11

## A FEW NOTES ON TUBULAR CARE

When folding ensure that the tread is on the outside of all bends. Keep tyres tightly stuck on rims—a tyre that "rolls" to one side will be cut through wall by edge of rim. Keep base tapes in good order—if rim spoke holes are allowed to chafe through, the main stitching will be damaged and blow-outs follow. Fill all cuts in tread with stopping compound—water penetrating these will rot tube pocket, causing twisting, uneven wear and blow-outs. Do not over-tighten connector on valve when inflating—this tends to loosen valve securing nuts and a slow leaking will follow. Tubular walls chafe easily—protect them when carried as spares, on wheels or folded under saddle. Do not leave wet tyres in a deflated condition—pockets will deteriorate.

## CLEMENT TUBULARS

A selection of the more popular tyres from this Italian Manufacturer.

<b>Super 10.</b> Track and short distance. Smooth band	7½ oz.	74/6
<b>"50".</b> Fast road tyre. Lateral rib tread ... ..	11 oz.	54/-
<b>Elvezia.</b> Road and circuit. Ribbed tread ... ..	14 oz.	35/11
<b>Enwell.</b> General use. New black rib tread ... ..	15 oz.	30/11



## PIRELLI TUBULARS

<b>Leggerissimo.</b> Light road tyre. Puncture resistant	8 oz.	<b>75/-</b>
<b>Leggero.</b> Road tyre. Rib and file tread ... ..	9 oz.	<b>72/6</b>
<b>Gran Premio.</b> General use. File tread ... ..	14½ oz.	<b>42/6</b>

## DUNLOP TUBULARS

<b>No. 0.</b> For Sprinting ... ..	6 oz.	<b>65/6</b>
<b>No. 1.</b> Very fine file tread ... ..	8½ oz.	<b>69/-</b>
<b>No. 2.</b> Fast short distance tyre ... ..	9½ oz.	<b>69/-</b>
<b>No. 3.</b> Good road tyre ... ..	10 oz.	<b>69/-</b>
<b>No. 5.</b> Massed-start tyre ... ..	12¼ oz.	<b>69/-</b>
<b>No. 8.</b> For rough circuits ... ..	12½ oz.	<b>52/6</b>
<b>No. 9.</b> Training tubular ... ..	15 oz.	<b>41/6</b>
<b>No. 10.</b> Winter tubular ... ..	17¼ oz.	<b>41/6</b>
<b>SILKS.</b> No. 0 ... ..	<b>99/6</b>	
Nos. 2 and 5 ... ..		<b>104/6</b>

## TUBULAR CARRIER

**"FULMINE"** Italian Quick-Release Carrier with strong elastic cords. Fitted under the saddle. When making rapid change remains attached to the saddle. No fiddling with loose straps **7/6**

## TUBULAR SUNDRIES

<b>"D'Alessandro"</b> 25 yards linen thread and needle ...	<b>1/3</b>	card
<b>"Dunlop"</b> Sprint repair outfit. Contains all necessities	<b>6/-</b>	tin
<b>"Constrictor"</b> repair outfit for puncture repairs ...	<b>3/-</b>	tin
<b>"Dunlop"</b> Patches for tubular inner tubes ... ..	<b>6d.</b>	pkt.
<b>"Stopping Compound"</b> for filling cuts in tread ...	<b>4d.</b>	tube
<b>"Proofing Solution"</b> Preservative dressing for side walls	<b>3/6</b>	tin
<b>"Montex"</b> Latex dressing for side walls ... ..	<b>2/6</b>	jar
<b>"Dunlop Rim Cement"</b> for sticking tubular to rim ...	<b>3/6</b>	tin
<b>"Dunlop Tacky Tape"</b> double sided for sticking tub. to rim ... ..	<b>2/11</b>	roll
<b>"Jantex"</b> Continental tacky tape for sticking tub. to rim	<b>2/2</b>	roll

## TYRE SAVERS

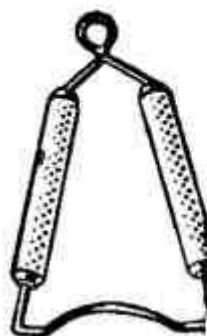

**CARLTON.** The Carlton Tyresaver is an ingenious device which removes nails, glass, or flints. As the wheel turns, the nail or flint comes into contact with the Tyresaver and is pulled out within a few seconds of its entry into the tyre, before it is able to penetrate to the tube.

<b>"CC"</b> Lightweight anti-splash guard	<b>2/-</b>	each
<b>"C"</b> Racing (illustrated) ... ..	<b>1/6</b>	"
<b>"CL"</b> Ultra-light Racing (single arm)	<b>1/6</b>	"
<b>"M"</b> or <b>"R"</b> for use with guards ...	<b>2/-</b>	"

## INDEX

Allen Keys ... ..	23/36	Leggings ... ..	2
Ankle Socks ... ..	1	Maps ... ..	30
Arm Warmers ... ..	12	Massage Cream ... ..	21
Bags—Touring and Pannier ... ..	15	Mass Start Caps ... ..	1
" Carriers and Supports ... ..	16	Mitts ... ..	3
Bath Salts ... ..	21	" —Racing ... ..	14
Bells ... ..	16	Mudflaps ... ..	2
Bends ... ..	25	Musettes ... ..	15
Berets ... ..	1	Oilers ... ..	30
Bottles—Feeding ... ..	16	Pannier Bags and Carriers ... ..	15/16
" " Carriers ... ..	17	" " Quick Release ... ..	16
Bracket Fittings ... ..	17	Pantalons de Paris ... ..	5
Brakes and Sundries ... ..	17/18/19	Pedals ... ..	31/32
Capes ... ..	2	" Spanners ... ..	36
Cardigans ... ..	11/12	Plastic Repair Outfits ... ..	2
Carriers—Bag ... ..	16	Pumps ... ..	33
" Bottle ... ..	17	" Connections and Clips ... ..	33
" Tubulars ... ..	39	Puncture Preventers ... ..	39
Chains ... ..	21	Racing Caps ... ..	1
Adjusters ... ..	21	" Jerseys and Vests ... ..	6
Chainwheel Sets ... ..	19/20	" Shorts ... ..	6
Chain Rings and Bolts ... ..	19/20/21	" Mitts ... ..	14
Cogs ... ..	22/27	Rims—Sprint and Wired-on ... ..	34
Connections ... ..	33	" Cement ... ..	39
Cotter Pins ... ..	21	" Tapes ... ..	34
Cranks ... ..	20	Rivet Extractors ... ..	21
Crash Hats ... ..	3	Saddles and Sundries ... ..	35
Derailleurs ... ..	23/24/25	" " Spanners ... ..	36
Drinking Tubes ... ..	16	Seat Pins ... ..	35
Dynamo Sets ... ..	30	Shorts ... ..	6/7
Embrocation, etc. ... ..	21	Shoes ... ..	9/10/11
Entry Forms ... ..	21	" Plates and Laces ... ..	11
Extensions (Handlebar) ... ..	26	Shoulder Bags (Sacco) ... ..	15
Feeding Bottles ... ..	16	Sou'westers ... ..	2
Flint Catchers ... ..	39	Spats ... ..	2
Freewheels and Sundries ... ..	22	Spanners ... ..	19/23/36
Front Changers ... ..	23/24	Sprint Wheel Carriers ... ..	34
Gauntlets ... ..	3	Sprockets ... ..	20/27
Gears and Sundries ... ..	23/24/25	Stems ... ..	26
Gloves ... ..	3/4	Stockings ... ..	8
" —Racing ... ..	14	Sun Specs ... ..	14
Handlebar Bends ... ..	25	Sweaters ... ..	11/12
" Stems or Extensions ... ..	26	Tape—Handlebar ... ..	26
" Tape ... ..	26	" Double Sided Sticky ... ..	39
" End Plugs ... ..	26	" Rim ... ..	34
Handi-bags ... ..	15	Toe Straps and Clips ... ..	36
Head Fittings ... ..	27	Touring Bags ... ..	15
Honking Rubbers ... ..	19	Track Mitts ... ..	14
Hose ... ..	8	" Nuts ... ..	27
Hubs ... ..	28/29	" Shorts ... ..	6
" Cogs ... ..	27	" Suits ... ..	13
" Gears ... ..	25	" Vests ... ..	6
" Track and Wing Nuts ... ..	27	Training Suits ... ..	12/13
Jackets ... ..	4	Trousers ... ..	5
Jeans ... ..	5	Transfers ... ..	23
Jerseys ... ..	6/11/12	Tubulars ... ..	37/38/39
Kleenfeet ... ..	2	Tyre Savers ... ..	39
Lamps—Lucifer ... ..	30	Wing Nuts ... ..	23
Leg Warmers ... ..	12	Woolen Racing Legs ... ..	12

### GEAR TABLE 27" WHEELS

	36	38	40	42	44	45	46	47	48	49	50	51	52	54
12	81.0	85.5	90.0	94.5	99.0	101.2	103.5	105.8	108.0	110.3	112.5	114.7	117.0	121.5
13	74.7	78.9	83.1	87.2	91.4	93.4	95.5	97.6	99.7	101.8	103.8	105.9	108.0	112.1
14	69.4	73.3	77.1	81.0	84.8	86.7	88.7	90.6	92.6	94.5	96.4	98.3	100.3	104.1
15	64.8	68.4	72.0	75.6	79.2	80.9	82.8	84.6	86.4	88.2	90.0	91.8	93.6	97.2
16	60.8	64.1	67.5	70.9	74.2	76.0	77.6	79.3	81.0	82.7	84.4	86.1	87.7	91.1
17	57.2	60.3	63.5	66.7	69.9	71.5	73.0	74.6	76.2	77.8	79.4	81.0	82.6	85.7
18	54.0	57.0	60.0	63.0	66.0	67.5	69.0	70.5	72.0	73.5	75.0	76.5	78.0	81.0
19	51.2	54.0	56.8	59.7	62.5	64.0	65.4	66.8	68.2	69.6	71.0	72.5	73.9	76.7
20	48.6	51.3	54.0	56.7	59.4	60.8	62.1	63.4	64.8	66.1	67.5	68.8	70.2	72.9
21	46.3	48.9	51.4	54.0	56.6	57.9	59.1	60.4	61.7	63.0	64.3	65.5	66.8	69.4
22	44.2	46.6	49.1	51.5	54.0	55.2	56.4	57.7	58.9	60.1	61.4	62.6	63.8	66.2
23	42.3	44.6	47.0	49.3	51.6	52.8	54.0	55.2	56.3	57.5	58.7	59.9	61.0	63.4
24	40.5	42.7	45.0	47.2	49.5	50.7	51.7	52.9	54.0	55.1	56.2	57.3	58.5	60.7
25	38.9	41.1	43.2	45.4	47.5	48.6	49.7	50.8	51.8	52.9	54.0	55.1	56.2	58.3
26	37.4	39.5	41.5	43.6	45.7	46.7	47.8	48.8	49.8	50.9	51.9	53.0	54.0	56.1

### GEAR TABLE 26" WHEELS

	36	38	40	42	44	45	46	47	48	49	50	51	52	54
12	78.0	82.3	86.6	91.0	95.3	97.5	99.7	101.8	104.0	106.2	108.3	110.5	112.7	117.0
13	72.0	76.0	80.0	84.0	88.0	90.0	92.0	94.0	96.0	98.0	100.0	102.0	104.0	108.0
14	66.8	70.5	74.2	78.0	81.7	83.5	85.4	87.3	89.1	91.0	92.8	94.7	96.6	100.3
15	62.4	65.9	69.3	72.8	76.3	78.0	79.7	81.5	83.2	84.9	86.6	88.4	90.1	93.6
16	58.5	61.7	65.0	68.3	71.5	73.1	74.7	76.4	78.0	79.6	81.2	82.9	84.5	87.7
17	55.0	58.1	61.2	64.2	67.3	68.8	70.3	71.9	73.4	74.9	76.4	78.0	79.5	82.6
18	52.0	54.9	57.7	60.7	63.5	65.0	66.4	67.9	69.3	70.8	72.2	73.6	75.1	78.0
19	49.2	52.0	54.7	57.5	60.2	61.7	62.9	64.3	65.7	67.0	68.4	69.8	71.2	73.9
20	46.8	49.4	52.0	54.6	57.2	58.5	59.8	61.1	62.4	63.7	65.0	66.3	67.6	70.2
21	44.5	47.0	49.5	52.0	54.5	55.8	57.0	58.2	59.4	60.7	61.9	63.1	64.4	66.8
22	42.5	44.9	47.2	49.6	52.0	53.1	54.4	55.5	56.7	57.9	59.1	60.2	61.4	63.8
23	40.6	42.9	45.2	47.5	49.7	50.8	52.0	53.1	54.3	55.4	56.5	57.6	58.8	61.0
24	39.0	41.2	43.3	45.5	47.7	48.6	49.8	50.9	52.0	53.1	54.2	55.2	56.3	58.5
25	37.4	39.5	41.6	43.7	45.8	46.9	47.8	48.9	49.9	50.9	52.0	53.0	54.1	56.1
26	36.0	38.0	40.0	42.0	44.0	45.0	46.0	47.0	48.0	49.0	50.0	51.0	52.0	54.0

