



TUBE SETS

2021 CATALOGUE
MADE IN ITALY



The Soul of Cycling since 1919

#ColumbusTubing

#Steelisreal



In 1919, as Europe emerged from the ashes of the Great War, a twenty-seven year old Angelo Luigi 'A.L.' Colombo signed the lease on a small factory and so began the production of steel tubes. With demand for bicycles running high, their makers were amongst his first customers – Edoardo Bianchi, Umberto Dei, Atala, Giovanni Maino. With his tubing well-proven in the bicycle industry, Angelo Luigi saw strength in creativity and diversity and was soon supplying material for the tubular frames of seaplanes and road vehicles, as well as for furniture and ski-poles. Italy was at the forefront of aviation in the 1920s, and Colombo enjoyed a strong relationship with Caproni, manufacturing the tubing that formed the backbone of their famous aircraft. In 1927 Colombo became part of aviation history, with De Pinedo and Balbo's transatlantic planes having airframes constructed from Colombo tubing – the same tubing that was, at that time, used to fabricate race-winning Moto Guzzi motorcycle chassis.

To give increased strength and reduced weight, Colombo began experimenting with 'butted' tubes – with variable wall thickness along their length.

Three years later, in 1930, Angelo Luigi created the brand name 'Columbus', which was initially only associated with tubular chromed-steel furniture. After an initial trial period, in which Columbus exhibited at the VI Triennale in Milan, Angelo Luigi obtained exclusivity of supply to EMBRU for the production of Marcel Breuer's iconic furniture designs. Shortly afterwards, Columbus furniture was in high demand – for offices, universities and schools as well as homes. The best rationalist architects of the time - Figini, Pollini, Terragni, Pagano, Pucci,

Faccioli - crafted designs for Columbus, bringing innovation to the furniture industry and further reinforcing the reputation of Columbus as leaders in modernist design. Later in the 1930s, the Columbus name, along with 'Aelle' and 'Tenax' was first applied to special sets of bicycle tubes – the Columbus tubes being drawn from Chrome Molybdenum steel and the fork blades being elliptical, laying down standard characteristics that remain commonplace to this day. Never satisfied, Colombo worked to the maxim "Curiosity is a prelude to knowledge" and continued to experiment in the fields of mechanics and metallurgy.

Colombo even designed and built their own butting machines to manufacture the tubes with tapering wall thickness – reinforcing the tubes at the joints where stresses are greatest.

Colombo supplied tubes for racing car chassis, and Colombo's son, Gilberto, designed chassis for the immortal Italian manufacturers Lancia, Maserati and Ferrari. Fangio ('El Maestro'), Ascari and 'Gigi' Villorosi were carried to victory on Colombo chassis. Some of the tube profiles created at this time will find their application onto bicycle frames in the following years.

'Columbus', a new company dedicated to the development and production of specialist tubes for bicycle frames, is formed in 1977. Antonio Colombo, youngest son of Angelo Luigi, leaves his position as President of A.L. Colombo to devote himself entirely to the new-born Columbus. Extensive experience gained from cycle, aircraft and automobile testing was the driving force of the business: Columbus, reinforced by the fact that the

Italian artisans who use Columbus tubes are admired and known all over the world, were determined to conquer international markets. Since that time continuous uninterrupted research, highlighting the parts of the frame subjected to the highest stress, has helped to improve stiffness and strength and increase resistance to deformation and breakage. Among the notable innovations are the taper-gauge elliptical fork blades, the conical helix tube butting, 'Air' – the first fully-aerodynamic tube set, and 'Max' – offering the advantages of differing oversize tube profiles to bicycle designers and riders. Parallel to an increasingly diverse production line, manufacturing 900 different types of tubes all of controlled origin and guaranteed quality, comes a growing competitive sector. For record attempts on the track, Columbus have developed super-light tube sets for the greatest champions: Coppi, Anquetil, Baldini, Rivière, Bracke, Ritter, Merckx, Moser, Oersted. The doctrine of intelligent experimentation and technological progress continues to be the main focus of the new Columbus, independent from A.L. Colombo since 1978. From research conducted in collaboration with the most prestigious research institutions, and through sophisticated tests carried out on the road and in the laboratory, Columbus continues to develop new materials and designs; new tube sets used by the top riders: from Gimondi to Merckx, Hinault to Argentin, Lemond and Roche, till nowadays new-generation hi-performance oversized steel tube-sets and carbon fibre monocoque forks, frames and components.



XCr

**Stainless,
Seamless,
Performance**

- The jewel of the crown, top-range tubeset
- The only biphasic stainless seamless tube family available in the cycling industry
- Tripled & Double butted tube reinforces
- High corrosion resistance in long-term periods in every use and weather condition
- Seamless-technology, improved stiffness and mechanical properties
- Reduced thickness, up to 0.4mm for an extremely reduced weight
- Exceptional resistance to Stress Corrosion Cracking
- No need to be painted or clear-coated after polishing
- Ultra smooth surface ($R_a < 0,4$)
- Excellent weldability
- Made in Italy



SPIRIT HSS

High Strength Shaped

- Triple butted OMNICROM alloy
- Cold-Drawn Seamless Tube
- Exceptional mechanical properties
- Special HSS shaping, designed to optimize tube strength according to the orientation of its local solicitations
- High tensile strength, superior resilience and incredible fatigue resistance
- Visual Quality Control inspection and hand marking of each tube
- Unpaired strength/weight ratio
- Made in Italy



SPIRIT

**Top-Performance
Road-Race**

- Triple butted OMNICROM alloy
- Cold-Drawn Seamless Tube
- Reduced thickness, up to 0.38mm
- Exceptional mechanical characteristics
- High tensile strength, superior resilience and incredible fatigue resistance
- Excellent tube-surface finishing and highly controlled alloy-composition, regular and close to nominal, for an excellent weld bead
- Visual Quality Control inspection and marking of each tube
- Incomparable strength/weight ratio
- Made in Italy



LIFE

**Over-size,
Lightness,
Resistance**

- Triple butted OMNICROM alloy
- Cold-Drawn Seamless Tube
- Wide range and great freedom in frame-design & tubeset-composition
- Excellent resistance/weight ratio, wide range of shapes & bends
- Over-sized tubes available for the DT ($\varnothing 42\text{mm}$) and the ST ($\varnothing 35\text{mm}$)
- Exceptional mechanical characteristics
- High breaking load, superior tenacity and incredible fatigue endurance
- Wide range of specifications: road-race, gravel, urban and mtb
- Made in Italy



MAX

**The Revolutionary
Tubeset**

- Triple butted OMNICROM alloy
- Cold-Drawn Seamless Tube
- The very first and only original patented non-round tubeset of the cycling history
- Tubes shapes oriented according to localized specific stress-direction
- Elliptical and oriented oversized sections for an increased momentum of inertia
- Maximized stiffness, reduced thickness, weight and power-dispersion
- Made in Italy



SL

**Super Leggera -
The 'Soul of Cycling'**

- Double butted OMNICROM alloy
- The most famous Columbus round set
- Hi-performance, imperial dimensions
- Exclusive laminated tapered fork blades swaged on shaped-mandrels for an improved structure and lightness
- Wide range with multiple diameters and thicknesses and reinforces
- Meets both lugged and Tig-welded frame needs
- Evergreen specifications updated to new technologies and alloys
- Double butted seamless tubes, cold worked and stress relieved
- Made in Italy



ZONA

**All-Purpose
Hi-Resistance
tubes family**

- Triple / Double butted 25CrMo4 alloy seamless tubeset
- Moderate weight and high strength
- Multiple possible shapes, triangle & stays
- Increased wall-thicknesses and butted lengths in strategic tube areas
- Perfect solution for offroad and training purpose
- Great to mix with lighter Columbus sets for an improved resistance
- Good resistance to heating during welding process
- Great reliability and fatigue life
- Made in Italy



CROMOR

**Resistance, Reliability,
Duration**

- Double & Single butted Cromor alloy
- Competitive and easy to weld & braze
- The legendary Columbus tubeset
- The ABC of framebuilding art
- Reinforced in the welding/junctions areas up to 0.8/0.9/1.2mm
- Tubes with reduced thickness up to 0.5/0.6mm
- Top reliability even in the most demanding and stressing conditions
- Long-lasting properties and performance even after heavy-duty use
- Improved performances with multiple cold-drawn & stress-relief processes
- Full-set made in Italy. 'Tre-Tubi' composition available ex-Asia for OE productions

Tubesets





XCr è un acciaio speciale inossidabile dalla formulazione innovativa. Caratteristica esclusiva ed unica nel settore del ciclo della nuova serie XCr Columbus, sono i tubi inossidabili senza saldatura, realizzati partendo da una billetta forata meccanicamente e trafilata a freddo innumerevoli volte fino ad ottenere ridottissimi spessori finali. In questo modo le elevate caratteristiche meccaniche dei tubi sono uniformi e costanti su tutta la sezione circolare del tubo. Grazie alla particolare composizione chimica di questa nuova lega, la struttura cristallina non viene alterata durante il processo di saldatura del telaio, garantendo le massime prestazioni anche nei punti di giunzione. Caratteristiche meccaniche: UTS=1450MPa, Ys=1000MPa, Ap5: >10% Materiale d'apporto suggerito per saldatura TIG: APX4S Materiale d'apporto per saldobrasatura: T99 (Ag 56% Cu 22% - Zn 17%)

XCr is an innovative, high grade, stainless seamless steel tubing set. Exclusive and unique characteristic for the whole bike industry of the new Columbus XCr set, is that the stainless steel tubes are seamless, made starting from a solid billet, machine-perforated and cold drawn countless times, to obtain the final required thickness. In this way the very high mechanical characteristics are uniform and constant in the whole round section of the tube. Thanks to the special chemical composition of this new alloy, the grain structure is not altered by welding during the frame construction. The maximum characteristics are granted also in the joint areas. Mechanical characteristics: UTS=1450MPa Ys=1000MPa, Ap5: >10% Suggested filler material for TIG welding: APX4S Suggested material for brazing: T99 (ag 56% Cu 22% - Zn 17%)



COLUMBUS Omnicrom

NEW!

A distanza di 30 anni dagli studi fatti da Columbus e l'Istituto di Saldatura di Parigi che portarono a brevettare le leghe Cyclax e Nivacrom, siamo oggi ad un nuovo traguardo nella storia degli acciai ad alta prestazione, siamo oggi pronti per presentare OMNICROM.

Le performance del telaio in acciaio sono direttamente influenzate dalle caratteristiche e qualità dei materiali e componenti utilizzati: senza sottovalutare la bontà della geometria e del progetto, grande importanza è da attribuirsi alla qualità dei tubi e della saldatura, con speciale riferimento alle ripercussioni che essa ha sui tubi utilizzati.

Columbus da sempre presta particolare attenzione alla resistenza dei propri tubi agli stress termici e alle trasformazioni che avvengono durante la fase di saldatura. Con l'introduzione di OMNICROM, Columbus inaugura una nuova era del tubo in acciaio: prestazioni senza precedenti e grandissima capacità di lavorazione.

OMNICROM è il punto di arrivo di un lungo percorso. Tutto parte dalle più aggiornate leghe di acciaio al Cromo-Molibdeno con basso tasso di Carbonio, utilizzate nel moderno ambito aeronautico, figlie delle prime ricerche delle acciaierie AL Colombo. Dall'esperienza sviluppata negli anni da Columbus nel campo delle competizioni motor e ciclo con leghe cromolly, OMNICROM si arricchisce dei benefici del Vanadio e di un accurato controllo del processo produttivo: la miglior scelta per il rider, la miglior scelta per il telaista.

Caratteristica distintiva di OMNICROM sono la strettissima tolleranza nella composizione della lega, affinata e rifusa per garantire la regolarità della struttura, la resistenza allo snervamento, l'ottima saldabilità e l'elevata resilienza.

La purezza dell'acciaio OMNICROM si traduce in assenza di inclusioni, tramite un attento controllo degli elementi del metallo, annullando eventuali comportamenti anomali della lega, dovuti ad impurità ed irregolarità presenti nella struttura del cristallo.

30 years have passed since Columbus and The Institute of Welding of Paris collaborated on a research study which led to obtaining patents on Cyclax and Nivacrom alloys. Today marks a new milestone in the history of high-performance alloys. Today we present OMNICROM.

The performance of a steel frame is, undoubtedly, directly influenced by the characteristics and quality of the materials and components used: in combination with the quality of the geometries and the project, big importance belongs to the quality of the material and of the welds, with particular attention paid to the effect they have on the tubes used for the realization of the frame.

Columbus has always paid particular attention to the resistance the tubes have to the thermal stress and transformations they are typically exposed during the welding phase. With the introduction of OMNICROM, Columbus ushers forth a new era of steel tubing; unprecedented performance and excellent processing capacity.

OMNICROM is the culmination of a long journey.

It all starts with the latest low-carbon Chromium-Molybdenum Steel alloys used today in the aerospace industry, descendants of the first research done at AL Colombo's steel mill.

Putting to use all the experience Columbus has gained within the competitive motorcycle and cycling industry developing Chromoly alloys, OMNICROM benefits from being enriched with Vanadium combined with a highly controlled production process: the best choice for riders, the best choice for framebuilders.

OMNICROM's distinctive features are the strict tolerance of the alloy composition, refined and re-fused to grant the regularity of the structure, an increased yield strength, excellent weldability and elevated resilience.

OMNICROM's purity translates into excluding inclusions, through careful control of the metal elements, eliminating any abnormal behavior of the alloy caused by these impurities and consequently irregularities within the crystal structure.



COLUMBUS Omnicrom

La centenaria esperienza di Columbus nei processi di trafilatura a freddo, assieme alle straordinarie proprietà di OMNICROM, permettono di raggiungere un'elevata regolarità della struttura cristallina del metallo. Il controllo della lega sin dal momento della solidificazione in colata, si traduce in maggiore capacità di assorbire il calore e lo stress della saldatura e mantenere stabili e inalterate le proprietà meccaniche anche dopo saldatura.

OMNICROM si lavora con grande facilità, ha un comportamento regolare e prevedibile durante la saldatura, si presta a realizzazioni TIG, saldo-brasatura fillet e a congiunzioni, grazie all'elevata temperatura di transizione ($Ac3=980^\circ$) che ne preserva inalterata struttura e performance anche dopo le lavorazioni più esasperate.

Le prestazioni di OMNICROM sono superiori agli acciai sino ad oggi brevettati da Columbus, grazie alla speciale composizione della lega, e all'innalzamento delle proprietà meccaniche ottenuto tramite la maggior deformabilità a freddo del tubo, realizzata per trafilatura, ottenuta grazie alle qualità di questa speciale lega.

Caratteristiche meccaniche:

UTS=1300MPa, $Y_s \geq 920$ MPa, $Ap5 > 15\%$.

Materiale d'apporto per TIG:

OK TIGROD 13.12 (AWS 5.28 ER 80S-G)

Materiale d'apporto per saldobrasatura:

Castoline Silver Alloy 38230

Columbus OMNICROM è utilizzato nei triangoli Spirit, Spirit HSS, Max, SL e Life.

The extraordinary properties of OMNICROM and a century of experience in cold drawing steel allows Columbus to achieve an elevated degree of crystal structure regularity. The crystal structure is controlled since casting solidification and grants a greater capacity to absorb the heat and stress of the welding process, maintaining the tube's mechanical properties stable and unaltered.

Thanks to its high transition temperature ($Ac3=980^\circ$), OMNICROM is easy to work with. It has a smooth, predictable behavior during welding and lends itself perfectly to TIG welding, as well as fillet and lug brazing maintaining an unaltered structure and performance even after undergoing the most extreme processes.

OMNICROM's performance is superior to steel alloys patented up to this day by Columbus. This superior performance is thanks to the special alloy composition and improved mechanical properties, which are obtained through the increased plastic deformation of the tubing achieved through cold-drawing, made possible thanks to a special alloy formula.

Mechanical characteristics: UTS=1300MPa, $Y_s \geq 920$ MPa, $Ap5 > 15\%$.

Suggested material for TIG welding: OK TIGROD 13.12 (AWS 5.28 ER 80S-G)

Suggested material for brazing: Castoline Silver Alloy 38230

Columbus OMNICROM is utilized for the production of the Spirit, Spirit HSS, Max, SL and Life main-triangles.

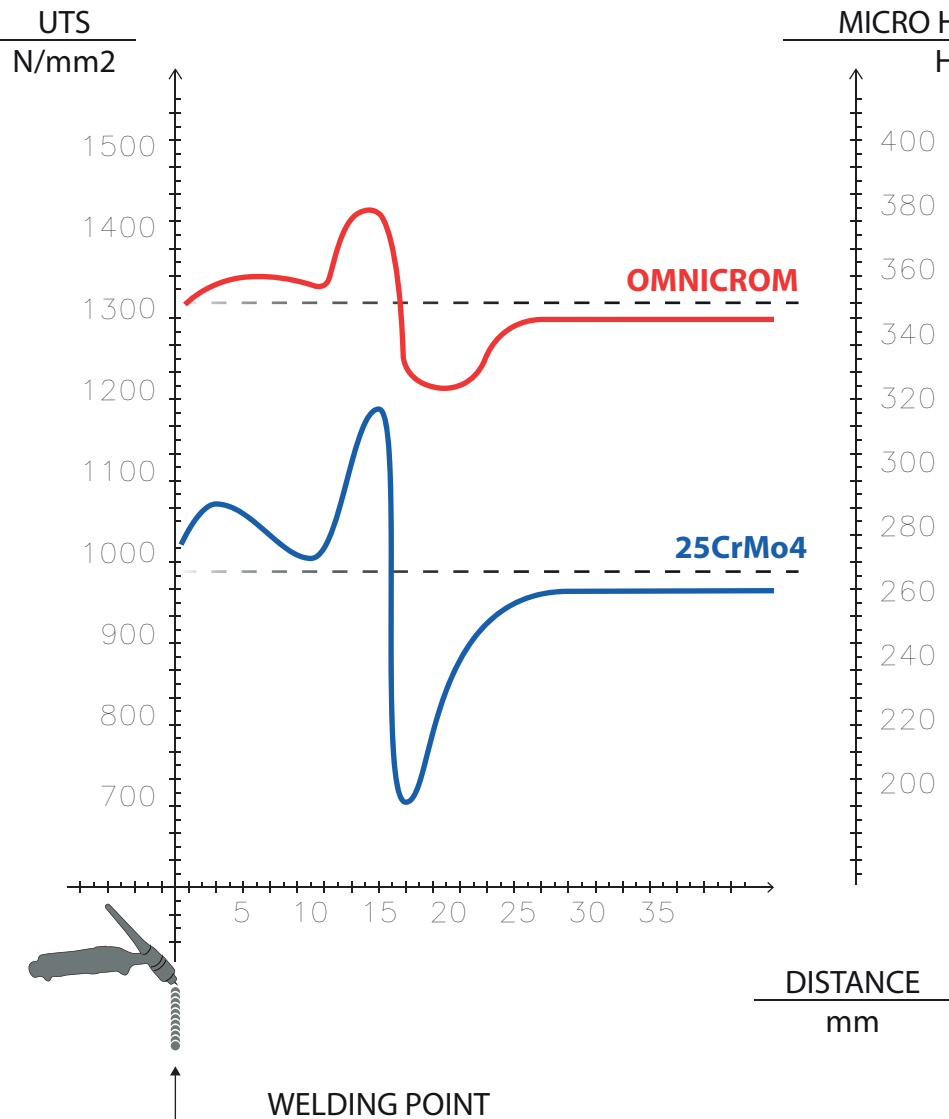

MECHANICAL CHARACTERISTICS COMPARISON OF COLUMBUS TUBES



THE VALUES ARE FOR HOMOGENEOUS SECTIONS
OF COLD-DRAWN STRESS-RELIEVED TUBING
FROM THE MAIN TRIANGLE

	N/mm ²
XCR	1450
OMNICROM	1300
NIOBIUM	1250
25CRMO4	900
CROMOR	750

The new Omnicrom alloy will soon be featured on all the Columbus top-range main-triangles, including Spirit, Spirit HSS, SL, MAX, and Life tubesets.



COLUMBUS 25CrMo4

Acciaio 25CrMo4 senza saldatura: grazie al Cromo l'acciaio resiste egregiamente al surriscaldamento dovuto alla saldatura, infatti, i grani non si ingrossano e le prestazioni meccaniche non vengono alterate. Brasatura o saldatura sono dunque ben sopportate. Questo acciaio, allo stato crudo malleabile, garantisce elevate caratteristiche meccaniche.

Caratteristiche meccaniche: UTS=900MPa, Ys=800MPa, Ap5 =12%

Materiale d'apporto per saldatura TIG: OKTIGROD 13.12 (AWS 5.28 ER 80S-G)

Materiale d'apporto per saldobrasatura: Castoline Silver Alloy 38230

Columbus 25CrMo4 è utilizzato nelle serie tubi Zona, 29r e FAT.

25CrMo4 seamless steel: the chemical composition of this steel, specifying a higher percentage of Chromium, gives to the material good resistance properties to overheating. The formation of carbides prevents the grain enlargement: the steel maintains its properties during brazing and welding, even in the malleable raw state it features excellent mechanical characteristics.

Mechanical characteristics: UTS=900MPa, Ys=800MPa, Ap5 =12%

Suggested filler material for TIG welding: OKTIGROD 13.12 (AWS 5.28 ER 80S-G)

Suggested material for brazing: Castoline Silver Alloy 38230

Columbus 25CrMo4 is utilized for the production of the Zona, 29r and FAT tubesets.



COLUMBUS Cromor

Columbus Cromor e' un acciaio 25CrMo4, saldato e trafilato a freddo su mandrini sagomati a spessore variabile.

Cromor e' prodotto partendo da uno sbozzato calibrato che ha già a sua volta subito due passaggi di trafilatura, prima di essere rinforzato a spessore variabile.

Caratteristiche meccaniche: UTS=750MPa, Ys=700MPa, Ap5 ≥ 12%

Materiale d'apporto per saldatura TIG: OK TIGROD 13.12 (AWS 5.28 ER 80S-G)

Materiale d'apporto per saldobrasatura: Castoline Silver Alloy 38230

Columbus Cromor is a 25CrMo4 steel, seamed and cold drawn, butted to variable thicknesses using shaped mandrills. Cromor steel is produced starting from a calibrated tube which has already received two drawing processes, before being reinforced in all the possible variable thickness offered by the range.

Mechanical characteristics: UTS=750MPa, Ys=700MPa, Ap5 ≥ 12%

Suggested material for TIG welding: OK TIGROD 13.12 (AWS 5.28 ER 80S-G)

Suggested material for brazing: Castoline Silver Alloy 38230

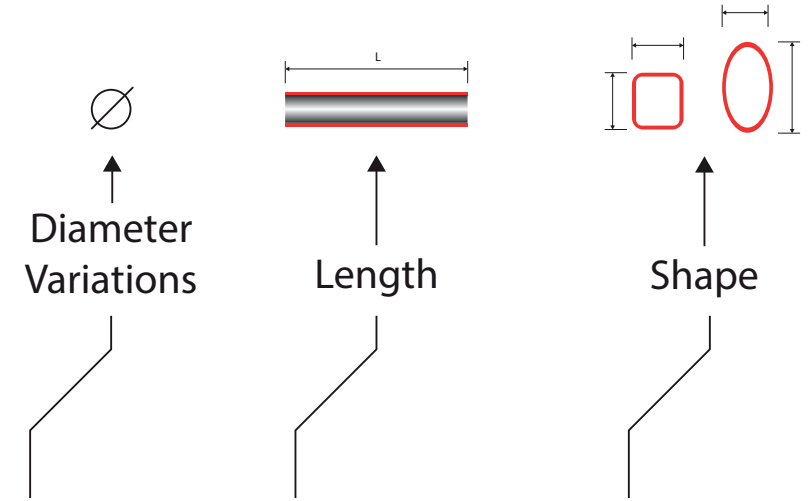
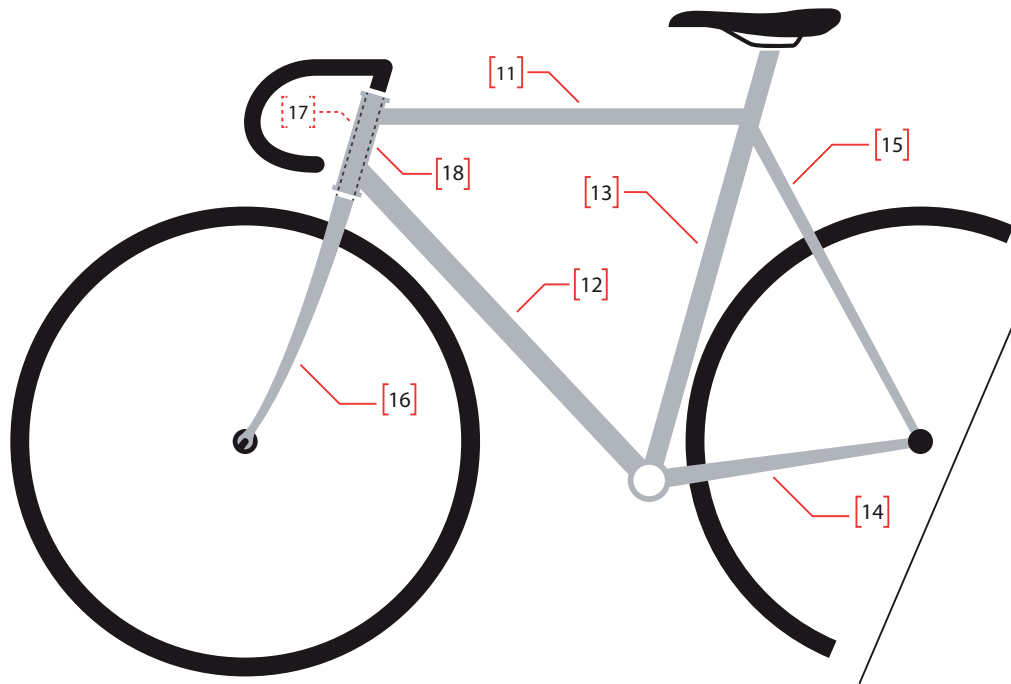

[SLF][L][13][635][112][A]

Columbus Bicycle Steel Tubes are hi-precision tubes manufactured using a cold-drawing hardening process, subject to a final stress-relieve heat treatment in order to release the internal tensions and optimize the crystalline structure of the alloy and its elements.

Family	ITA	ENG
XCR XCr	11 - TO	11 - TT
SP Spirit	12 - TQ	12 - DT
SL HSS/SL	13 - TV	13 - ST
SLF Life/HSS	14 - PO	14 - CS
ZON Zona	15 - PV	15 - SS
CR/CX Cromor	16 - FF	16 - FB
FBR Disc Blade	17 - CN	17 - FS
	18 - ST	18 - HT

Variations

COLUMBUS
TUBE-CODE LEGEND

Sagomature & Curve Shapes & Bends



SHAPES

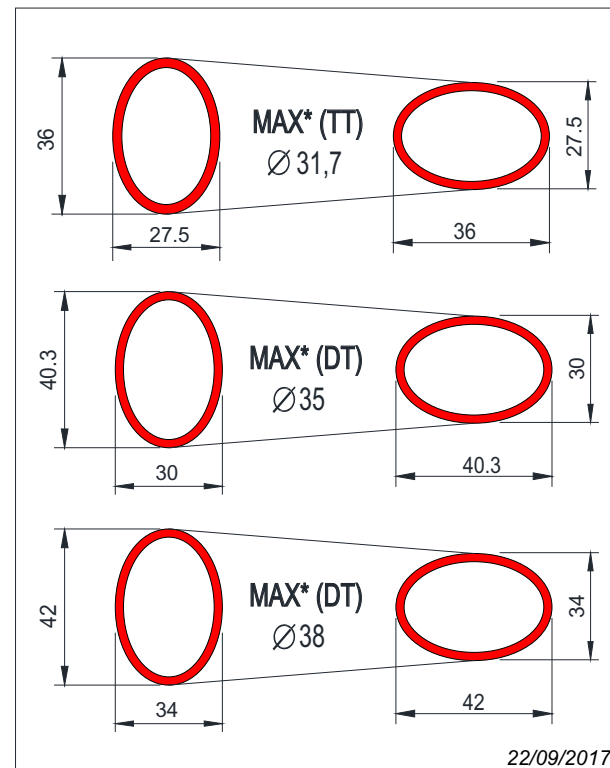
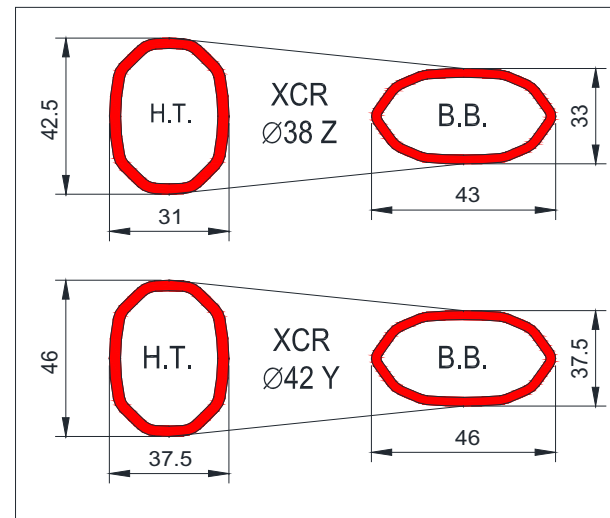
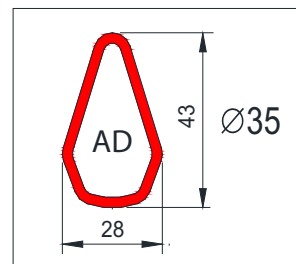
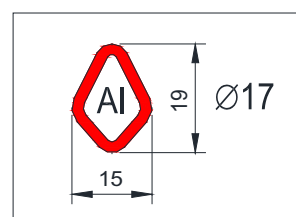
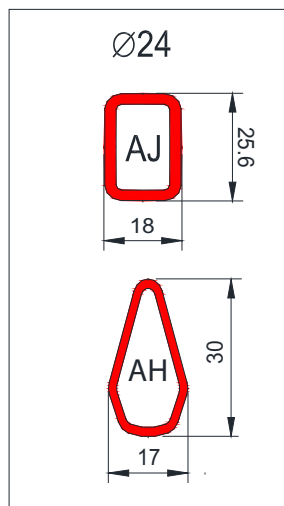
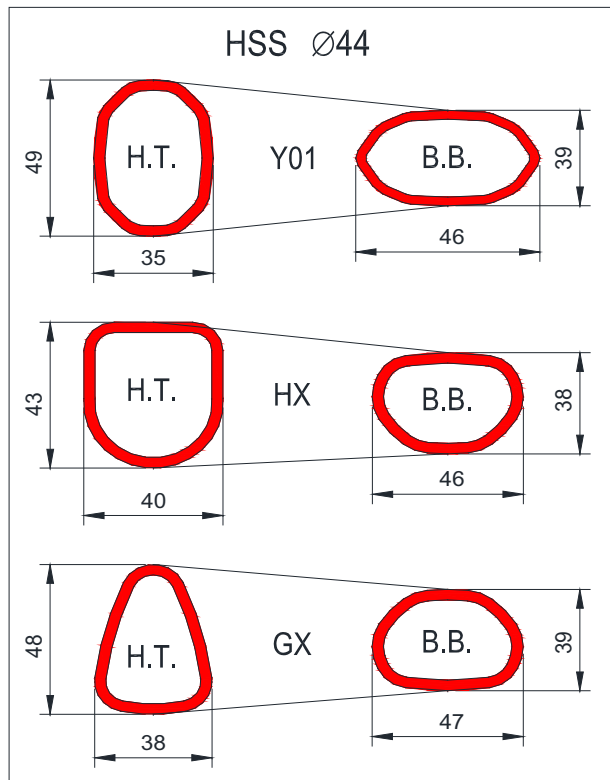
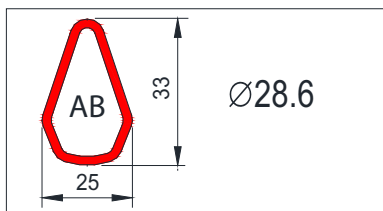
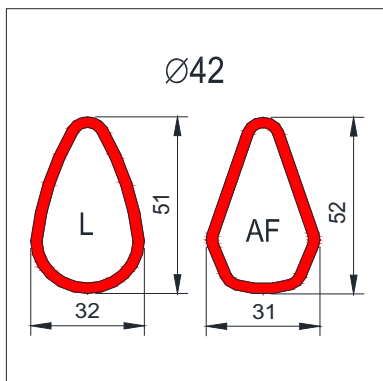
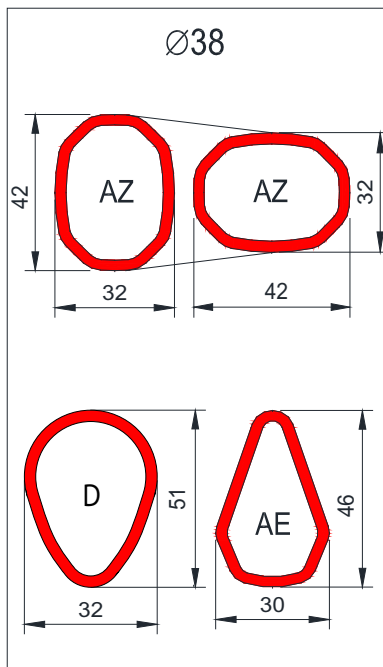
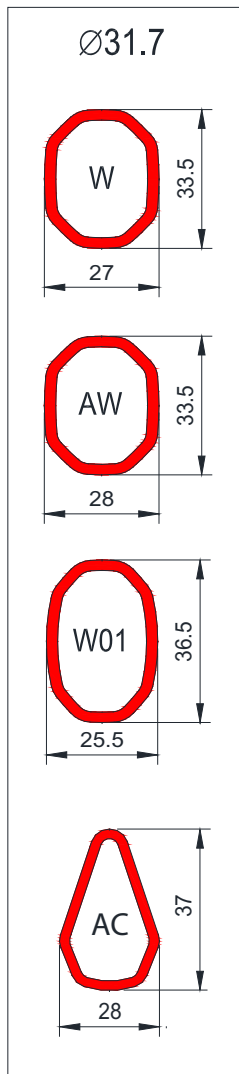

CHAIN STAYS single bend



CODE	L1	L2	L3	R1	R2	R3	X	Y	Z	FAMILY
ZON114V10425	300			320			10°			Zona
ZON114V12425	300			320			12°			Zona
ZON114OV440C10	300			320			10°			Zona

CHAIN STAYS double bend

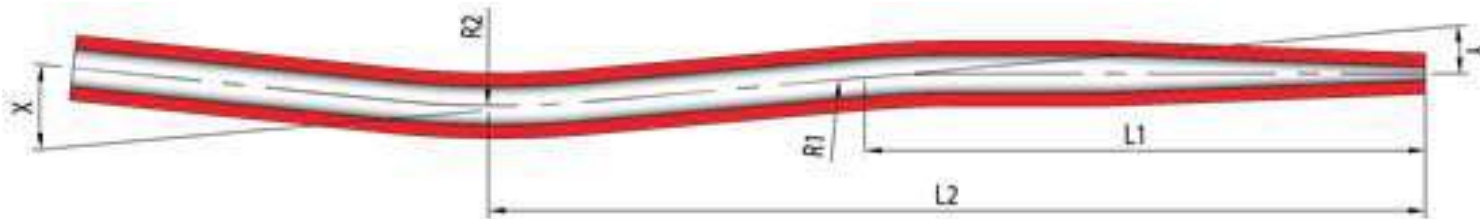

CODE	L1	L2	L3	R1	R2	R3	X	Y	Z	FAMILY
XCR 114OV425133CR**	150	310		320	320		5°	5°		XCR
SLF114OV410133E	150	310		320	320		4°	8°		Life
SLF114OV410133CR	150	310		320	320		8°	8°		Life
SLF114OV410133E	150	310		320	320		4°	8°		Life
SLF114OV410001133CR	150	310		320	320		8°	8°		Life
ZON114OV425133	150	310		230	230		12°	8°		Zona
ZON114OV425133CR	150	310		320	320		8°	8°		Zona
ZON114OV425133E	150	310		320	320		4°	8°		Zona
ZON114OV44029	150	345		230	230		12°	8°		29'r
ZON114OV470FAT	150	350		230	150		20°	7°		FAT

CHAIN STAYS Triple bend

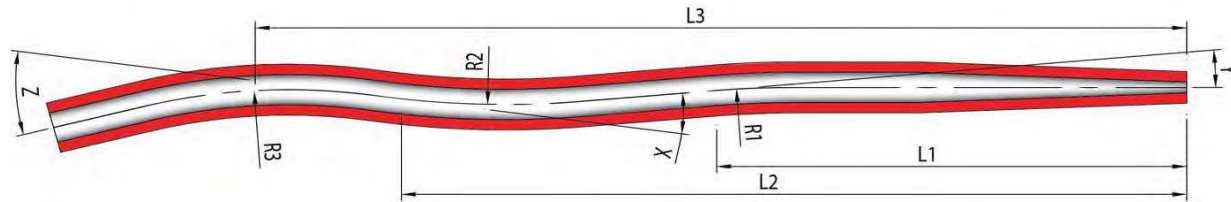

CODE	L1	L2	L3	R1	R2	R3	X	Y	Z	FAMILY
ZON114OV47029	150	330	420	230	230	230	15°	7°	15°	29'r

SEAT STAYS double bend

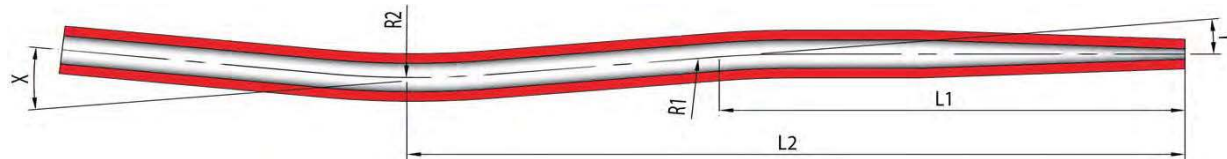

CODE	L1	L2	L3	R1	R2	R3	X	Y	Z	FAMILY
XCR615560133CR	210	335		250	250		8°	8°		XCR
SLF715560133E	210	330		320	320		4°	8°		Life
ZON615560133	220	335		320	320		15°	8°		Zona
ZON615560133CR	210	335		250	250		8°	8°		Zona
ZON615560133E	210	330		320	320		4°	8°		Zona
ZON915560133	220	335		250	250		15°	8°		Zona
ZON915560133CR	210	335		250	250		8°	8°		Zona
ZON915560133E	210	330		250	250		4°	8°		Zona
ZON91556029	220	345		250	250		18°	8°		29'r

SEAT STAYS single bend

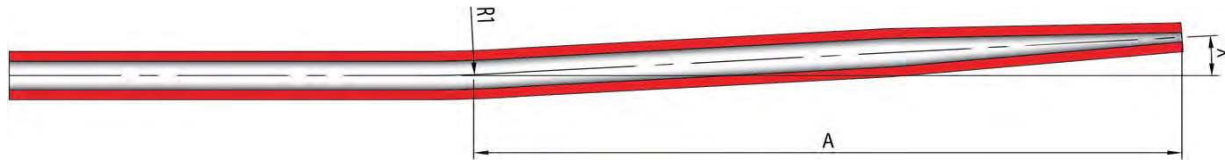

CODE	L1	R1	X	FAMILY
ZON915560FAT	345	250	18°	FAT

SEAT TUBE single bend

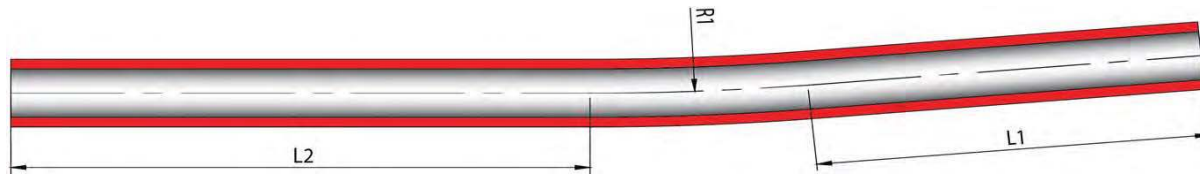

CODE	L1	L2	L3	R1	R2	R3	X	Y	Z	FAMILY
ZON113550110F	290	70		800						29'r

DOWN TUBE Single bend

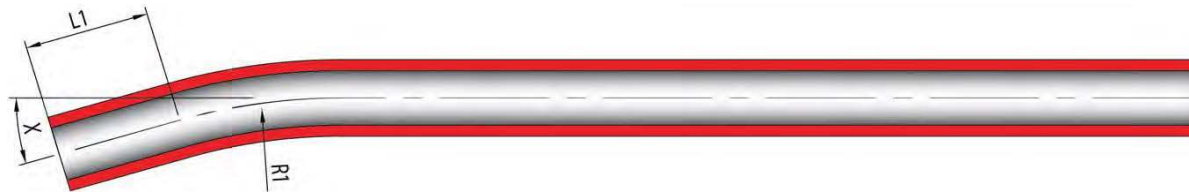

CODE	L1	L2	L3	R1	R2	R3	X	Y	Z	FAMILY
ZONA12750001110E	30			150			25°			29'r



GRUPPO SRL - DIVISIONE COLUMBUS
VIA G. DIVITTORIO, 21 - 20090 CALEPIO DI SETTALA (MI) ITALY

TEL. +39 02 95244.1 - FAX +39 02 95244.239
www.columbustubi.com - info@columbustubi.com